

TM 9-2320-244-20
 DEPARTMENT OF THE ARMY TECHNICAL MANUAL
 ORGANIZATIONAL MAINTENANCE MANUAL

This manual supersedes TM 9-2320-244-20, 28 October 1968, including all changes and TB9-2320-244-20, 18 July 1968.

TRUCK, CARGO: 1 1/4 TON, 4x4, M715 WO/WINCH (FSN 2320-921-6365) W/WINCH (FSN 2320-921-6366)	TRUCK, AMBULANCE: 1 1/4 TON, 4x4, M725 WO/WINCH (FSN 2320-921-6369)	TRUCK, MAINTENANCE, 1 1/4 Ton, 4X4, M726 W/O WINCH (FSN 2320-921-6370) W/WINCH (FSN 2320-921-6833)
--	---	---

Headquarters, Department of the Army
 AUGUST 1971

WARNING CARBON MONOXIDE POISONING CAN BE DEADLY

Carbon monoxide is a colorless, odorless DEADLY POISONOUS gas which, when breathed, deprives the body of oxygen and causes SUFFOCATION. Exposure to air contaminated with carbon monoxide produces symptoms of headache, dizziness, loss of muscular control, apparent drowsiness coma. Permanent BRAIN DAMAGE or DEATH can result from severe exposure.

It occurs in the exhaust fumes of fuel-burning heaters and internal-combustion engines and becomes DANGEROUSLY CONCENTRATED under conditions of INADEQUATE VENTILATION. The following precautions MUST be observed to insure the safety of personnel whenever the personnel heater, main auxiliary engine of any vehicle is operated for maintenance purposes or tactical use.

- a. DO NOT operate heater or engine of vehicle in an enclosed area unless it is ADEQUATELY VENTILATED.
- b. DO NOT idle engine for long periods without maintaining ADEQUATE VENTILATION in personnel compartments
- c. DO NOT drive any vehicle with inspection plates, cover plates, engine compartment doors removed unless necessary for maintenance purposes
- d. BE ALERT at all times during vehicle operation for exhaust odors and exposure symptoms. If either are present IMMEDIATELY VENTILATE personnel compartments. If symptoms persist, remove affected personnel from vehicle and treat as follows: expose to fresh air, keep warm: DO NOT PERMIT PHYSICAL EXERCISE: If necessary, administer artificial respiration.

THE BEST DEFENSE AGAINST CARBON MONOXIDE POISONING IS ADEQUATE VENTILATION!!!!

MAINTENANCE POLICY FOR 1¼ TON MILITARY TRUCKS

1. Purpose. The procedures as cited herein establishes the maintenance and support policy for the 1 1/4 Ton Military Truck.

2. Scope.

a. These procedures are applicable and mandatory to all Department of the Army organizations and activities authorized the use of, and responsibility for, maintenance and support of the 1 1/4 Ton Truck.

b. The maintenance and support policy established herein is applicable to the following vehicles:

- (1) Truck, Cargo 1 1/4 Ton 4x4 M715
- (2) Truck, Ambulance 1 1/4 Ton 4 x 4 M725
- (3) Truck, Maintenance (Telephone) 1 1/4 Ton 4x4 M726

3. Policy.

a. The following provisions are applicable to those major items Identified In paragraph 2b.

(1) Rebuild of major Items is prohibited. See Page No 333, AR 320-5, dated April 65, for definition of REBUILD. Functions, outlined in Maintenance Allocation Chart (TM 9-2320-244-24) as direct and general support category, will be performed by units or activities missioned to provide direct and general support. These functions may be performed within the depot when theater commanders designate a depot as a consolidated maintenance facility. These functions MUST be consistent with the skills, tools, equipment parts allocated, authorized and available to OVERHAUL major Item and/or major assemblies. See page No. 286, AR 320-5, dated April 1965, for definition of OVERHAUL

(2) Serviceable or economically repairable vehicles will be retained for redistribution within the major command. Vehicles excess to a major command will be reported in accordance with AR 755-6 or AR 755-10, as appropriate to the CG, ATAC, ATTN: AMSTA-FI, Warren, Michigan for possible redistribution to other major commands. Unserviceable vehicles, deemed repairable within the limits established herein, will be restored to the prescribed maintenance standards by the losing activity prior to redistribution in accordance with specific Instructions from ATAC.

(3) One 1 1/4 Ton vehicle will be classified uneconomically repairable each time an unserviceable engine installed in or removed from such a vehicle cannot be repaired in accordance with criteria established herein. The vehicle selected for classification as uneconomically repairable need not necessarily be the vehicle having the unrepairable engine. Instead, a 1 1/4 Ton vehicle in poorer overall condition, but having a serviceable or repairable engine, may be selected. The objective is to insure selection of the vehicle in poorest overall condition for washout in conjunction with an engine washout as an uneconomically repairable unit Maximum cannibalization will be practiced on both the unserviceable engine and vehicle, in accordance with AR 750-50. Disposition will be in accordance with AR 700-10. The controlled cannibalization procedure outlined herein will be executed in accordance with the evacuation policy of the major command.

(4) Repair expenditure limits set forth in AR 750-2300-7 do not apply. a vehicle will be classified as uneconomically repairable and reported to CG, ATAC, ATTN: AMSTA-FI, for disposition when it has attained eight (8) years of age from date of manufacture or when it has accumulated 50,000 miles (whichever occurs first). Depot storage time will be deducted from the vehicle age at a rate of (6) months for each one (1) year period vehicle was in storage prior to issue. A replacement vehicle (M715, M725, M726) MUST be requisitioned for each vehicle reported to CD, ATAC, ATTN: AMSTA-FI, for disposition, if accountable assets are equal to or less than authorizations. When the replacement vehicle is received the over-age vehicle MUST be turned in for cannibalization in accordance with AR 750-50.

b. The following provisions are applicable to the below listed major assemblies the 1 1/4 Ton Truck:

Engine

Transmission

Transfer

Front Axle Assembly

Rear Axle Assembly

(1) The above listed major assemblies will not be repaired beyond the scope of operations, standards, skills, and repair parts prescribed for general support maintenance

(a) Machining or other manufacturing type operations to restore the major assemblies to serviceability is prohibited.

(b) Engine repair overhaul is limited to replacement of cylinder heads, pistons, piston rings, connecting rods, connecting rod inserts, crankshaft, main bearing inserts, camshaft, cam deck, valves, valve seats, valve rocker arms, valve guides, timing gears, and timing gear chains.

(c) Deboring or resleeving of cylinder blocks is prohibited.

(d) Installation of oversize pistons is prohibited.

(e) Regrinding crankshaft journals is prohibited.

(f) Installation of undersize bearings is prohibited

(2) Major assemblies will not be evacuated to depot facilities for rebuild. If required, the Theater Commander may evacuate major assemblies to depot facilities for overhaul. However, when such a depot has been designated a consolidated maintenance facility, the use of funds that are programmed for depot REBUILD to restore major Items and/or major assemblies is prohibited.

(3) Major assemblies will be procured by the wholesale supply system only in sufficient quantities to meet initial maintenance requirements of field maintenance organizations and activities. These assemblies will be provided on a one-time basis to overseas commands and CONUS stations on a free-issue basis as the major item becomes available for distribution. Major assemblies will be distributed only to direct support or general support units (not to distribution depots) authorized major assemblies and will be used as the base for maintenance support throughout the service life of the 1 1/4 Ton Truck.

(a) Excess major assemblies which are serviceable or economically repairable will be retained for redistribution within the major command.

(b) No sales return credits will be granted for these items by the Army Stock Fund.

(c) No resupply or stockage of these assemblies is planned or authorized at the wholesale supply level.

(d) Requirements for major assemblies generated subsequent to completion of supply actions cited in paragraph 3b (3) above will be satisfied by repair of sets within the major command, and cannibalization of an uneconomically repairable major Item in accordance with this regulation and AR 750-50.

TABLE OF CONTENTS:

Chapter/Section	Description	Paragraphs
CHAPTER 1.	INTRODUCTION	
Section I	General	1-1, 1-6
II	Description and Data	1-7, 1-8
CHAPTER 2	ORGANIZATIONAL MAINTENANCE INSTRUCTIONS	
Section I.	Service Upon Receipt of Materiel	2-1, 2-3
II.	Repair Parts, Special Tools and Equipment	2-4, 2-6
III.	Lubrication Instructions	2-7, 2-9
IV.	Preventive Maintenance Checks and Services	2-10, 2-12
V.	Troubleshooting the Vehicle	2-13, 2-14
VI.	Troubleshooting the Electrical System	2-15, 2-17
VII.	Radio Interference Suppression	2-18, 2-21
VIII.	Power Plant Removal and Installation	2-22, 2-24
IX.	Maintenance of Engine	2-25, 2-29
X.	Maintenance of Clutch	2-30, 2-34
XI.	Maintenance of Fuel System	2-35, 2-39
XII.	Maintenance of Exhaust System	2-40, 2-44
XIII.	Maintenance of Cooling System	2-45, 2-49
XIV.	Maintenance of Ignition System	2-50, 2-54
XV.	Maintenance of Starting System	2-55, 2-59

XVI.	Maintenance of Generating System	2-60, 2-64
XVII	Maintenance of Batteries and Lighting System	2-65, 2-69
XVIII.	Instrument Panel, Instruments, Switches, Indicators, Sending Unit, Horn and Lights	2-70, 2-74
XIX.	Maintenance of Transmission, Gearshift and Controls	2-75, 2-78
XX.	Maintenance of Transfer Case Assembly	2-79, 2-83
XXI.	Maintenance of Propeller Shafts and Universal Joints	2-84, 2-90
XXII.	Maintenance of Front Axle, Front Suspension and Steering Mechanism	2-91, 2-95
XXIII.	Maintenance of Rear Axle and Rear Suspension	2-96, 2-100
XXIV.	Maintenance of Brakes	2-101,2-105
XXV.	Maintenance of Wheels, Hubs, Drums and Tires	2-106, 2-110
XXVI.	Maintenance of Frame, Pintle, Towing Shackles, Lifting Brackets, and Spare Tire Wheel Carrier	2-111, 2-115
XXVII.	Maintenance of Cab and Body	2-116, 2-120
XXVIII.	Maintenance of Body, Chassis and Accessory Items	2-121, 2-125
CHAPTER 3	MAINTENANCE OF MATERIAL USED IN CONJUNCTION WITH THE VEHICLE	
Section I.	General	3-1, 3-3
II.	Winch and Power Takeoff	3-3, 3-7
III.	Deep Water Fording Equipment	3-8, 3-12
IV.	100-Ampere Alternator Kit	3-13, 3-17
V.	Arctic Enclosure Kit	3-18, 3-22
VI.	Fresh Air Heater and Defroster Kit	3-23, 3-27
CHAPTER 4	ADMINISTRATIVE STORAGE	4-1, 4-4
APPENDIX A	REFERENCES	A-1, A-4
APPENDIX B	TORQUE REQUIREMENTS	C-1, C-2
INDEX	INDEX	

CHAPTER 1

INTRODUCTION

Section I. GENERAL

1-1. Scope.

This manual contains instructions for the use of organizational maintenance personnel maintaining the Truck, cargo: 1-1/4 ton, 4 x 4, M715; Truck, ambulance: 1-1/4 ton, 4 x 4, M725 and Truck, maintenance: 1-1/4 ton, 4 x 4, M726 as allocated by the Maintenance Allocation Chart. It provides information on organizational maintenance of the equipment, its accessories, auxiliaries, and materiel used in conjunction with equipment. This manual also includes instructions for shipment, limited storage, and deprocessing. TM 9-2320-244-20p contains the repair parts and special tool list authorized to organizational maintenance for the aforementioned vehicles.

1-2. Forms and Records.

The forms generally applicable to units maintaining this materiel are listed in Appendix A. For a listing of all forms, refer to BA Pam 310-2. For instructions on the use of these forms, refer to TM 38-750

1-3. Equipment Serviceability Criteria,

Equipment Serviceability Criteria for Cargo Truck M715, Ambulance Truck M725 and Maintenance Truck M726 is contained in TM 9-2320-244-ESC.

1-4. Reporting of Errors.

Report of errors, omissions, and recommendations for improving this publication by the individual user is encouraged. Reports should be submitted on DA form 2028, Recommended Changes to Publications, and forwarded direct to: Commanding General, U. S. Army Tank Automotive Command, Attn. AMSTA-MAP, Warren, Michigan, 48090.

1-5. Administrative Storage.

Refer to TM 740-90-1 for administrative storage of equipment. Those requirements peculiar to M715, M725 and M726 vehicles are contained in Chapter 4 of this manual

1-6. Destruction of Army Materiel to Prevent Enemy Use.

- a. The destruction of army materiel to prevent enemy use is a command decision, implemented only on the authority of the Division Commander or a higher Commander.
- b. Instructions for destruction of the vehicles covered in this manual are outlined in Operator s Manual TM 9-2320-244-10.

Section II. DESCRIPTION AND DATA

1-7. Description.

A general description of Cargo Truck M715, Ambulance Truck M725 and Maintenance Truck M726 and information pertinent to identification plates is contained in TM 9-2320-244-10. External features of the vehicles are shown in figures 1-1 through 1-3. Detailed descriptions of the various specific components and assemblies are provided in the applicable maintenance paragraphs of this manual.

- a. Identification. The M715 Cargo Truck, M725 Ambulance and M726 Maintenance Truck have one major identification plate each. It is mounted on the instrument panel cowling immediately to the right of the instrument panel assembly. The information contained on this plate is listed as follows:

Name Plate	Winch Drive Control
Shipping Data	Speed Caution Plate
Servicing Date	Shifting Instructions and Publication Data

1-8. Identification and Tabulated Data.

**M-715 CARGO TRUCK****M-725 AMBULANCE****M-726 MAINTENANCE**

TECHNICAL SPECIFICATIONS FOR:	715 W/OW	715 W/W	725	726 W/OW	726 W/W
CURB WEIGHT, FULLY EQUIPPED LESS PAYLOAD AND CREW, FRONT AXLE	2800 LBS.	3300 LBS.	2800 LBS.	3200 LBS.	3700 LBS.
CURB WEIGHT, FULLY EQUIPPED LESS PAYLOAD AND CREW, REAR AXLE	2700 LBS.	2700 LBS.	3600 LBS.	3300 LBS.	3300 LBS.
TOTAL CURB WEIGHT, BOTH AXLES	5500 LBS.	6000 LBS.	6400 LBS.	6500 LBS.	7000 LBS.
PAYLOAD* CROSS COUNTRY LIMITED**	2500 LBS.	2500 LBS.	2000 LBS.	2000 LBS.	2000 LBS.
PAYLOAD* HIGHWAY	3000 LBS.	3000 LBS.	2000 LBS.	2500 LBS.	2500 LBS.
GROSS WEIGHT, FULLY EQUIPPED, PLUS PAYLOAD AND CREW, FRONT AXLE	3000 LBS.	3500 LBS.	3000 LBS.	3400 LBS.	3900 LBS.
GROSS WEIGHT, FULLY EQUIPPED, PLUS PAYLOAD AND CREW, REAR AXLE	5400 LBS.	5400 LBS.	5800 LBS.	5500 LBS.	5500 LBS.
TOTAL GROSS WEIGHT, BOTH AXLES	8400 LBS.	8900 LBS.	8800 LBS.	8900 LBS.	9400 LBS.
TOWED LOAD ALLOWANCE, CROSS COUNTRY	2840 LBS.	2840 LBS.	N/A	2840 LBS.	2840 LBS.
TOWED LOAD ALLOWANCE, HIGHWAY	3590 LBS.	3590 LBS.	N/A	3590 LBS.	3590 LBS.
SHIPPING DIMENSIONS, CUBIC FEET	606	640	980	730	764
SQUARE FEET	124	130	124	130	136
LENGTH	209 3/4 IN.	220 3/4 IN.	209 3/4 IN.	220 3/4 IN.	231 3/4 IN.

WIDTH	85 IN.	85 IN.	85 IN.	85 IN.	85 IN.
HEIGHT, OVERALL	95 IN.	95 IN.	95 IN.	80 IN.	80 IN.
HEIGHT, LOWEST OPERABLE	59 IN.	59 IN.	95 IN.	67 IN.	67 IN.
CENTER OF GRAVITY AT CURB WEIGHT, ABOVE GROUND	31 IN.	31 IN.	39 IN.	32 IN.	32 IN.
CENTER OF GRAVITY AT CURB WEIGHT, REARWARD FROM CENTERLINE OF FRONT AXLE	60.7 IN.	56.6 IN.	71 IN.	63.8 IN.	59.7 IN.
CENTER OF GRAVITY W/HIGHWAY PAYLOAD, ABOVE GROUND	32 IN.	32 IN.	42 IN.	34 IN.	34 IN.
CENTER OF GRAVITY W/HIGHWAY PAYLOAD, REARWARD FROM CENTERLINE OF FRONT AXLE	84.4 IN.	80.4 IN.	84 IN.	77.9 IN.	73.9 IN.
PERFORMANCE AT GROSS W/O TOWED LOAD, MAX SPEED	60 MPH	60 MPH	60 MPH	60 MPH	60 MPH
PERFORMANCE AT GROSS W/O TOWED LOAD, MAX GRADE	60 %	60 %	60 %	60 %	60 %
PERFORMANCE AT GROSS W/O TOWED LOAD, MAX CRUISING RANGE	225 MILES	225 MILES	225 MILES	225 MILES	225 MILES
PERFORMANCE AT GROSS W/TOWED LOAD, MAX SPEED	60 MPH	60 MPH	N/A	60 MPH	60 MPH
PERFORMANCE AT GROSS W/TOWED LOAD, MAX GRADE	58 %	58 %	N/A	58 %	58 %
PERFORMANCE AT GROSS W/TOWED LOAD, MAX CRUISING RANGE	225 MILES	225 MILES	225 MILES	225 MILES	225 MILES

* ADD 2 MAN CREW W/GEAR (400 LBS. TOTAL)

** FOR LIMITED CROSS COUNTRY USE ONLY.

SYSTEM SPECIFICATIONS

ENGINE:

TYPE	OVERHEAD CAMSHAFT
NUMBER OF CYLINDERS	6
BORE	3.344"
STROKE	4.375"
PISTON DISPLACEMENT	230 CUBIC INCH
BORE SPACING, CENTER TO CENTER	3.876"
FIRING ORDER	1-5-3-6-2-4
COMPRESSION RATIO	7.5:1
COMPRESSION PRESSURE	135 TO 145 PSI
HORSEPOWER, SAE	26.77
HORSEPOWER, MAX BRAKE	132.5 @ 4,000 RPM
TORQUE, MAX	198 LBS.-FOOT AT 2,000 RPM
IDLE SPEED	600 TO 650 RPM
OIL CAPACITY INCLUDING FILTER	6 QUARTS

TRANSMISSION:

TYPE	MANUAL
SPEEDS	FOUR FORWARD, ONE REVERSE
SYNCHROMESH	SECOND, THIRD, FOURTH GEARS
RATIOS:	
FIRST GEAR	6.398:1
SECOND GEAR	3.092:1
THIRD GEAR	1.686:1
FOURTH GEAR	1.00:1
REVERSE GEAR	7.820:1
LUBRICANT CAPACITY	6.5 PINTS

TRANSFER CASE:

TYPE	NEW PROCESS GEAR, 200 SERIES
RANGES	HIGH AND LOW
RATIOS:	
HIGH	1.00:1
LOW	1.96:1
LUBRICANT CAPACITY	4.5 PINTS

DIFFERENTIALS:

FRONT:

TYPE	FULL FLOATING, HYPOID GEARS, DANA 60
------	--------------------------------------

RATIO 5.87:1
LUBRICANT CAPACITY 6 PINTS

REAR:
TYPE FULL FLOATING, HYPOID GEARS, DANA 70
RATIO 5.87:1
LUBRICANT 6.5 PINTS

ELECTRICAL SYSTEM:

VOLTAGE 24 VOLTS
CURRENT 60 AMPERES
BATTERY:
QUANTITY 2
HOUR RATING 45 AMPERE HOUR
VOLTAGE 24 VOLT, 2-12 VOLT BATTERIES IN SERIES
TERMINAL GROUND NEGATIVE

FUEL SYSTEM:

CAPACITY 28 GALLONS

COOLING SYSTEM:

CAPACITY WITH HEATER 12 QUARTS
NORMAL OPERATING TEMP. 190 DEGREES
NORMAL OPERATING PRESSURE 13 PSI

STEERING SYSTEM:

TYPE MECHANICAL
STEERING RATIO 24:1
TURNING RADIUS 27.5 FEET
TURNING CIRCLE 55 FEET

SUSPENSION:

FRONT AND REAR SEMI-ELLIPTICAL SPRINGS

BRAKES:

TYPE PARKING BRAKE	HYDRAULIC, INTERNAL EXPANDING MECHANICAL, EXTERNAL ON PROP SHAFT
-----------------------	---

FORDING DEPTH:

WITHOUT KIT	30 INCHES
WITH KIT	60 INCHES

ARTICULATION:

ANGLE OF APPROACH W/OW	45 DEGREES
ANGLE OF APPROACH W/W	33 DEGREES
ANGLE OF DEPARTURE	25 DEGREES

TIRES:

TYPE	NYLON CORD, NON-DIRECTIONAL, MS (MUD & SNOW)
SIZE	9.00-16, 8 PLY
PRESSURE:	
FRONT	25 PSI
REAR	35 PSI
SPARE	35 PSI

CHAPTER 2

ORGANIZATIONAL MAINTENANCE INSTRUCTIONS

Section I. SERVICE UPON RECEIPT OF MATERIEL

2-1. General.

- a. When a new or reconditioned vehicle is first received by the using organization, it is necessary for organizational maintenance personnel to determine whether the vehicle has been properly prepared for service by the supplying organization and that it is in condition to perform any mission to which it may be assigned. Inspect all assemblies, subassemblies, components and accessories to insure that they are properly assembled, secured, clean and correctly adjusted. Check all tools and equipment to be sure every item is present, in good condition, clean and properly mounted or stowed.
- b. Perform a break-in of all new or reconditioned vehicles to completely check their operation. Refer to TM 9-2820-244-10 for operating instructions, break-in operating precautions, and operating speeds.

2-2. General Preliminary Services.

CAUTION Drycleaning solvent and mineral spirits paint thinner are flammable and should not be used near an open flame. Use only in well ventilated areas to avoid prolonged breathing of fumes.

- a. Uncrate vehicle, if crated. Remove metal strapping, plywood, tape, seals, wrapping paper and desiccant bags. If any exterior surfaces are Sated with rust-preventive compound, remove it with drycleaning solvent or mineral spirits paint thinner.
- b. Read and follow all precautions indicated in DD Form 1397, Processing Record for Shipment and Storage of Vehicles and Unboxed Engine Tag. This tag should be attached to the steering wheel, shifting lever, or ignition switch.
- c. Remove spark plugs or protective plugs from cylinder head and crank engine at least two revolutions to test for hydrostatic lock. This precaution is taken because there might be an excess of preservative oil in the combustion chambers or, possibly, coolant may have leaked into them.
- d. On processed materiel, when engine has been stored for over 30 days, service engine as outlined in TB ORD 392.

2-3. Specified Preliminary Services.

- a. Perform the S (6-month or 6,000 mile) preventive maintenance services. Refer to table 2-2 for specific procedures.
- b. Lubricate vehicle in accordance with Lubrication Order, LO 9-2320-244-12, regardless of interval, excluding gearcases and engine. Check processing tag for gearcases and engine oil. If tag states that oil is suitable for 500 miles of operation and is of the proper viscosity for local climatic operation, check the lubricant level, but do not change.
- c. Schedule the second S service on DD Form 314 Preventive Maintenance Schedule and Record, and arrange for oil change at 500 miles.
- d. Perform a road test of at least 5 miles on all new or reconditioned vehicles to completely check their operation. Perform maintenance procedures as listed below.

(1) Maintenance procedures prior to road test.

- (a) Insure that coolant, fuel, and oil levels are adequate and that the vehicle will without damage operate satisfactorily to perform the road test.
- (b) Inspect pulleys and fan for alinement. Check water pump and hoses for leakage. Adjust fan and alternator drive belts to correct tension (para 2-46j).
- (c) Visually inspect electrical wiring, conduits, connectors and shielding.
- (d) Inspect under vehicle for indications of gear oil, coolant, or brake fluid leakage.
- (e) Check steering system and components for looseness or damaged parts.
- (f) Check and adjust tire pressure to prescribed psi. Remove any penetrating objects such as glass or nails.
- (g) Make a general inspection of body, tops, bows, canvas, lights and reflectors. Observe seat mountings and upholstery. Operate lights, horn and windshield wipers.
- (h) Check service brake pedal for proper travel and handbrake for proper adjustment. Refer to paragraph 2-102 for adjustment procedures.

(2) Maintenance during road test.

- (a) With ignition switch on, start engine. Note if the starter switch requires more than normal pressure, and if the starter engages smoothly without unusual noise and turns the engine with adequate cranking speed.
- (b) Observe all instruments for normal indications. Note whether the ignition switch and light switch levers operate freely and make positive contact. Check all other instruments for normal operation.
- (c) In warming up the engine, check that choke operates satisfactorily. Note if idling speed is satisfactory. Listen for any unusual noises at idle and higher speeds. When operating vehicle, note if it has normal power and acceleration in each speed range. Listen for any unusual noises when the engine is under load. Speed up vehicle, on a level road, to see if it will reach, but not exceed, the maximum specified speed.
- (d) Observe battery/alternator indicator to check that alternator is charging properly. Listen for unusual noises.
- (e) Note if the clutch pedal has the proper free travel and if action of pedal return spring is satisfactory. Note whether clutch disengages completely. Observe smoothness of engagement and tendency to drag, grab, chatter, slip, or any unusual noise. With transmission in neutral, depress and release clutch pedal while listening for noises that may indicate a defective release bearing.
- (f) Shift transmission into all speeds and transfer into all ranges, observing any unusual stiffness of shift levers, tendency to slip out of gear, unusual noises, or excessive vibrations.
- (g) Note if action of brake return spring is satisfactory. Observe if pedal goes too close to floor. Make several stops, noting side pull, noise, chatter, grabbing

or any other abnormal condition. Check that the handbrake lever ratchet holds. Stop vehicle on an incline and apply handbrake to determine if it holds vehicle. Refer to paragraph 2-102 for handbrake adjustment procedures.

(h) With vehicle moving straight ahead, determine if there is any tendency to wander, shimmy, or pull to one side. Turn steering wheel through its entire range and note any binding.

(i) At all times during the road test, be alert for unusual noises that may indicate looseness, defects, or deficient lubrication at any point.

(3) Maintenance after road test.

(a) Immediately after the road test, feel hubs, drums, axles and power train components. If lubricant levels are correct and no unusual noises occurred during the road test, assume that the axles are functioning properly. An overheated wheel hub and drum may indicate an improperly adjusted, defective, or dry wheel bearing, or a dragging brake. An abnormally cool condition may indicate an inoperative brake. An over-heated gearcase may indicate lack of lubrication, gears out of adjustment, or defective parts.

(b) Clean top of batteries. Check electrolyte level. Level should be to the split ring in each cell.

(c) Perform a hydrometer test of electrolyte in each cell of both batteries and record results on DA Form 2404. A fully charged battery should have a specific gravity of 1.280 in each cell. Refer to hydrometer temperature correction chart in (para 2-66b).

(d) Inspect vehicle exhaust system for indications of exhaust leakage. Tighten mountings where required. On ambulance truck, operate the patient compartment heater and inspect heater exhaust system for leakage and proper operation.

(e) Check carburetor air cleaner to determine if air cleaner element requires cleaning.

(f) Inspect the radiator core for foreign matter obstructions and for bent core fins. Check gasket in the pressure cap. Observe coolant level and examine coolant for contamination. Test coolant with hydrometer to see if it contains sufficient antifreeze to correspond with seasonal requirements. Tighten radiator hose clamp screws and radiator mounting bolts. If need is indicated, drain cooling system. Clean and refill, adding corrosion inhibitor unless antifreeze containing inhibitor is used (para 2-46).

(g) Clean strainer in the fuel tank filler pipe. Check fuel lines for looseness. Check fuel tank attaching strap torque to determine that they are secure.

(h) Inspect front and rear bumpers, towing shackles lifting attachments and pintle. Check operation of pintle and note whether it locks securely.

(i) Inspect power take-off, winch drive shaft and shearpin. Inspect winch cable and check winch operation. Check if vent in the worm housing is clean.

(j) Inspect propeller shaft assemblies. Tighten universal joint companion flange bolts.

(k) Check under vehicle for evidence of oil, water, hydraulic fluid, or lubricant leakage. Inspect front and rear axle, transmission and transfer case ventilation lines for indications of leakage.

(l) Inspect springs, shackles, shock absorbers, and attaching parts for damage, breakage or looseness.

(m) Wash vehicle; clean inside of cab, glass and mirrors. Clean engine compartment as required. Do not steam clean vehicle.

(n) Lubricate vehicle completely in accordance with the Lubrication Order, LO 9-2320-244-12.

(o) Fuel vehicle in accordance with unit procedures.

Section II. REPAIR PARTS, SPECIAL TOOLS AND EQUIPMENT

2-4. Common Tools and Equipment.

Standard and commonly used tools and equipment having general application to this materiel are authorized for issue by Tables of Allowances (TA), Tables of Organization and Equipment (TOE), and Tables of Distribution and Allowances (TDA) applicable to organizational maintenance units.

Special Tools and Equipment.

Special tools and equipment designed for organizational maintenance are listed in table 2-1, and illustrated in figure 2-1 for information only. This list is not to be used for requisitioning replacements.

Special tools and equipment required for organizational maintenance are listed and illustrated in the Repair Parts and Special Tool List TM 9-2320-244-20P, which is the authority for requisitioning replacements.

ITEM	FSN or part number	Reference figure	Paragraph	USE
Puller	5120-168-2280	2-1	2-93f	Remove steering wheel
Wrench	5120-168-2286	2-1	2-107b	Adjust Wheel Bearings
Wrench	5120-168-2283	2-1	2-52d	Remove spark plug waterproof cable
Wrench	5120-168-2348	2-1	2-81b	Remove and install speedometer cable coupling

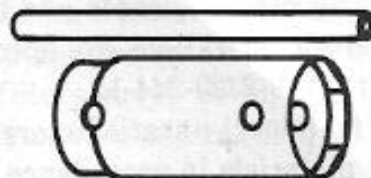

5120-168-2286

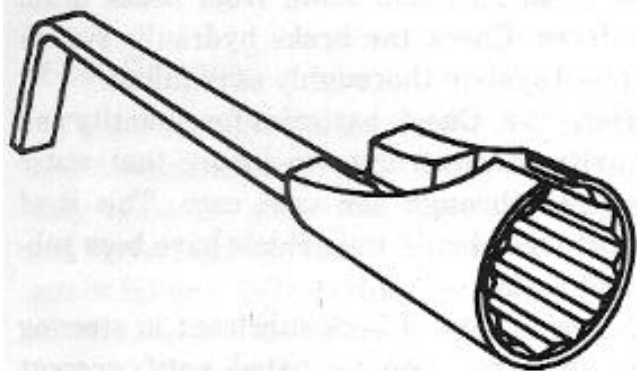

5120-168-2348

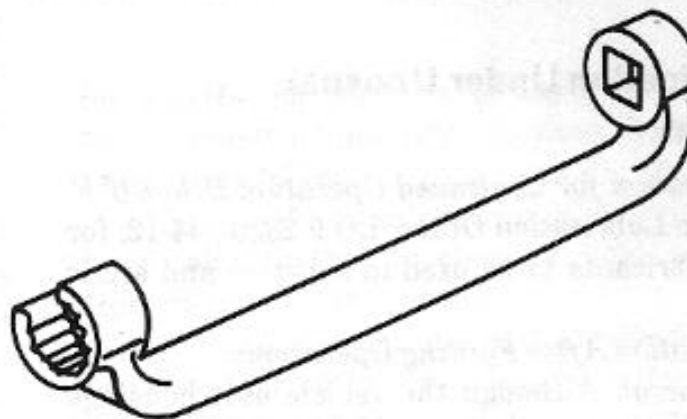

5120-168-2283

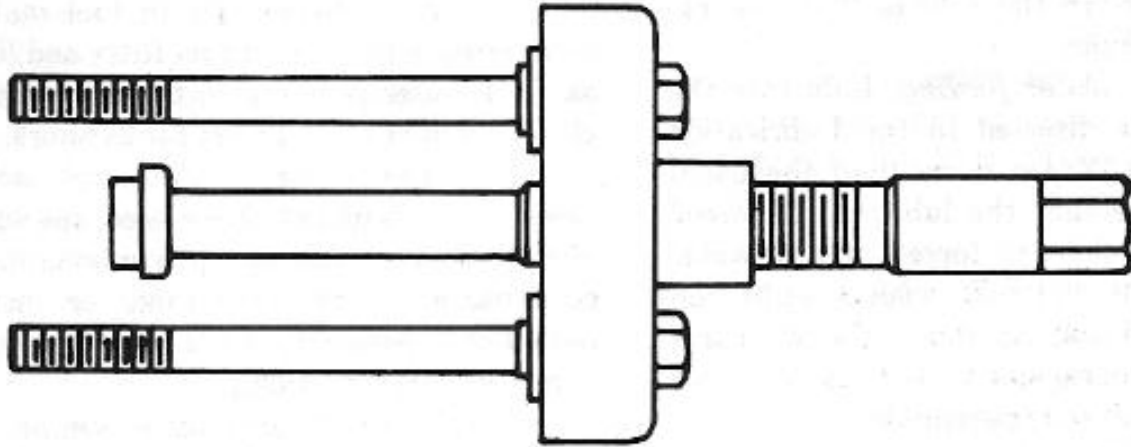

Figure 2-1 Special tools

2-6. Maintenance Repair Parts.

Maintenance repair parts and equipment authorized for use by organizational maintenance are listed and illustrated in TM 9-2320-244-20P, which is the authority for requisitioning replacements.

Section III. LUBRICATION INSTRUCTIONS

2.7. General.

The Lubrication Order, LO 9-2320-244-12, prescribes cleaning and lubricating procedures as to locations, intervals and proper lubricants to be used for this materiel. Lubrication to be performed will be in accordance with the lubrication order. Whenever necessary, the operator, crew, or user will assist the organizational maintenance personnel in lubrication operations.

2-8. General Lubrication Instructions.

- a. General. Any special lubricating instructions required for Specific mechanisms or parts are covered in the pertinent maintenance sections.
- b. Service Intervals. Service intervals specified on the lubrication order are for normal operation and where moderate temperature, humidity, and atmospheric conditions prevail.
- c. Special Lubricants. Special lubricants and lubricants for sub-zero and arctic operations are specified in the Lubrication Order, LO 9-2320-244-12.
- d. Records and Reports. Report unsatisfactory performance of preserving materials in accordance with instructions in paragraph 1-2.
- e. Painting. Instructions for the preparation of the materiel for painting, methods of painting, and materials to be used are contained in TM 9-213. Instructions for camouflage painting are contained in FM 5-20.

2-9. Lubrication Under Unusual Conditions.

- a. Lubrication for Continued Operation Below 0°F.

Refer to the Lubrication Order, LO 9-2320-244-12, for grade of lubricants to be used in sub-zero and arctic operations.

b. Lubrication After Fording Operations.

(1) General. Although the vehicle unit housings are sealed to prevent the free flow of water into the housings, it must be realized that some water may enter during submersion. The following services should be accomplished on all vehicles which have been completely submerged or exposed to some depth of water, especially in salt water. Precautions should be taken as soon as practicable to halt deterioration and avoid damage before the vehicle is driven extensively in regular service.

(2) After shallow water fording. Lubricate the chassis thoroughly as directed in the Lubrication Order, LO 9-2320-244-12. Do more than the usual lubrication job. Insure that the lubricant is forced into each lubrication point to force out any water present. Remove front and rear wheels, hubs and drums. Wash all wheel bearings thoroughly with drycleaning solvent or mineral spirits paint thinner. Air dry the bearings, repack and reassemble.

(3) After deep water fording.

(a) Body and chassis. Drain and clean out body, engine, and tool compartments. Clean and dry all tools and equipment. Clean all exposed paint surfaces and touch up where necessary. Coat unpainted metal parts with engine lubrication oil. Lubricate the chassis thoroughly as directed in the Lubrication Order, LO 9-2320-244-12. Insure that the lubricant is forced into each lubrication point to force out any water present.

(b) Engine, transmission, transfer case and axles. Check the lubricant in engine, transmission, transfer case, and axles. Should there be evidence that water entered drain, flush and refill with the correct lubricant as specified in Lubrication Order, LO 9-2320-244-12. Drain engine oil and replace engine oil filter element. Thoroughly lubricate propeller shaft slip joints such that any contaminated lubricants are forced out.

(c) Wheels and brakes. Flush out the steering knuckle flanges with a half and half mixture of engine oil and drycleaning solvent or mineral spirits paint thinner. Refill with the correct lubricant. Remove wheels and wash all wheel bearings thoroughly with drycleaning solvent or mineral spirits paint thinner. Air dry bearings and repack with the proper lubricant. While wheels are removed, dry out brake linings and clean rust and scum from brake drum bearing surfaces. Check the brake hydraulic system for water; bleed system thoroughly as required.

(d) Batteries. Check batteries for quantity and specific gravity of electrolyte to insure that water has not entered through the vent caps. This is of special importance should the vehicle have been submerged in salt water.

(e) Steering gear. Check lubricant in steering gear. If the lubricant is contaminated, notify support maintenance activity for removal and cleaning of the gear assembly. Thoroughly lubricate steering column universal joints and slip joint to force out any contaminated lubricant.

(f) Electrical connections. Check all screw on electrical connections for moisture and corrosion. Clean as required.

(g) Fuel system. Drain fuel tank of any accumulated water. Clean fuel filter and lines as necessary. If water is found in the air cleaner, clean air cleaner element and air dry for 24 hours.

(h) Condensation. Although units such as cases and instruments are sealed, the sudden cooling of the warm interior air upon submersion may cause condensation within the cases or instruments. A period of exposure to warm air after fording should eliminate this condition.

(i) Aluminum or magnesium parts. If vehicle remains in salt water for any appreciable length of time, aluminum or magnesium parts which were exposed to the water should be thoroughly inspected and cleaned before further use.

c. Lubrication after Operation in Mud. Thorough cleaning and lubrication of all parts affected must be accomplished as soon as possible after operation in mud, particularly when a pool of liquid mud has been traversed. Clean engine grille, radiator fins and interior of engine compartment. Clean mud from wheels, tires and fenders. Remove brake drums and clean mud from brake linings, flange plates, wheel cylinders and brake drum bearing surfaces. Repack wheel bearings. Carefully inspect electrical connections and clean as necessary. Clean and inspect exterior of all driveshafts, steering controls, clutch, transfer case and power take-off linkage and controls, Lubricate completely to insure that all contaminated lubricant is forced out.

d. Lubrication After Operation Under Dusty or Sandy Conditions. Clean engine and engine compartment. Lubricate completely to force out lubricants contaminated by sand or dust. Air cleaners, fuel and oil filters must be cleaned and/or replaced. Clean radiator core and engine grille.

Section IV. PREVENTIVE MAINTENANCE CHECKS AND SERVICES

2-10. General.

To insure that Cargo Truck, Maintenance Truck and Ambulance are ready for operation at all times, they must be inspected systematically to discover and correct defects before they result in serious damage or failure. Defects discovered during operation of the vehicle will be noted and recorded on DA Form 2404 (Equipment Inspection and Maintenance Worksheet) at the earliest possible opportunity after operation has ceased.

- a. All of the general maintenance procedures outlines in the operator s manual will be followed. Organizational maintenance personnel must be so thoroughly trained in these procedures that they will automatically apply them at all times during the performance of their duties.
- b. The driver or crew should accompany the materiel and assist organization maintenance personnel in the performance of the services.
- c. The driver or crew should present the vehicles for a scheduled preventive maintenance service in a reasonably clean condition; that is, it should be dry and not caked with mud to such an extent as to seriously hamper inspection and service. However, washing of the vehicle should be avoided immediately prior to an inspection, since certain types of malfunctions such as loose parts and oil leaks may not be evident immediately after washing.

2-11. Preventive Maintenance Checks and Services.

Specific procedures for performing each item in the preventive maintenance inspection are outlined in table 2-2. The results of preventive maintenance checks and services may be used as authorization to take corrective action at the organizational maintenance level. If repairs by a higher category of maintenance are required, DA Form 2407, Maintenance Request, will be prepared and forwarded with the materiel to the supporting maintenance activity.

2-12. Cleaning.

a. General. Special cleaning instructions required for specific mechanisms or parts are contained in the pertinent maintenance sections. General instructions are as follows:

- (1) Use drycleaning solvent or mineral spirits base paint thinner to clean or wash grease or oil from all parts of the vehicle.
- (2) A solution of one part grease-cleaning compound to four parts of drycleaning solvent or mineral spirits base paint thinner may be used for dissolving grease and oil from engine block, chassis, and other parts. Use cold water to rinse off any solution which remains after cleaning.
- (3) After the parts are cleaned, rinse and dry them thoroughly. Apply a light grade of oil to all polished metal surfaces to prevent rusting.
- (4) When authorized to install new parts, remove any preservative materials such as rust preventive compound, protective grease, etc. Prepare parts as required and for those parts requiring lubrication, apply the lubricant specified in the lubrication order.

NOTE Steam cleaning will not be performed by organizational maintenance personnel.

b. General Precautions in Cleaning are as Follows:

- (1) Drycleaning solvent and mineral spirits base paint thinner are flammable and should not be used near an open flame. Fire extinguishers should be provided when this materiel is used. Use only in well ventilated places. Battery ground cable should be disconnected from the battery terminal prior to cleaning operations.
- (2) This cleaner evaporates quickly and has a drying effect on the skin. If used without gloves, it may cause cracking of the skin, and, in some cases a mild irritation or inflammation might occur on some individuals.
- (3) Avoid getting petroleum products, drycleaning solvent, mineral spirits base paint thinner, engine fuels, or lubricants on rubber parts, as they will deteriorate the rubber.
- (4) The use of diesel fuel oil, gasoline or benzene (benzol) for cleaning purposes is prohibited.

Table 2-2. Organizational Preventive Maintenance Check, and Services

3000 Miles or 6 Months			
SEQUENCE	ITEM TO BE INSPECTED	PROCEDURES	PARAGRAPH REFERENCE
1	Oil and coolant	Check oil and coolant levels.	
2	Radiator and cap.	Check radiator core for foreign matter obstruction and bent core fins. Check gasket in pressure cap. Check coolant level and examine coolant for contamination. Test coolant with hydrometer to determine that coolant conforms to seasonal requirements. Examine radiator hose clamps and mounting bolts. If necessary, drain cooling system. Clean and refill. Add corrosion inhibitor unless anti-freeze containing inhibitor is used. (Drain and refill is scheduled for 12,000 mile or annual service).	2-45
3	Water pump, fan and pulleys.	Inspect pulleys and fan alinement. Check water pump for leakage. Check fan and alternator drive belt tension.	2-46j
4	Engine compartment.	Inspect engine compartment for indications of fuel, engine oil and coolant leakage. Inspect underneath vehicle for indications of gear oil or brake fluid leakage.	
5	Electrical wiring.	Visually inspect electrical wiring, conduits, connectors and shielding.	
6	Tires.	Note any apparent loss of air pressure. Check tires with tire pressure gage for correct pressure as specified.	
7	Fire Extinguisher.	Visually inspect fire extinguisher. Check that it is fully charged and sealed.	3-1c
8	Tools and equipment.	Inspect vehicle tools and equipment (including vehicle publications) for general condition and proper stowage.	
9	Steering gear and controls.	Check steering system and component parts for looseness and/or damage. Inspect for indications of lubricant leakage.	2-94
10	Doors, glass, top frame, curtains, fasteners, straps.	Test operation of doors, windows, windshield, hood hinges and fasteners. Inspect seat mountings and cushions. Inspect litter racks and operation of personnel heater (Ambulance only). Perform a general inspection of body including glass, panels, tops, fenders, tailgate, chains, stakes, bows, paulins, curtains and brush guards. Check for serviceability. Check identification, caution plates and vehicle markings for legibility.	2-119

11	Lights, horn and windshield wipers.	Operate horn and windshield wipers. Inspect rearview mirrors. Check operation of exterior lights and light switches. Note condition of all lights and reflectors. Check operation of spotlight switch and handle. Test operation of surgical light, dome light, blowers and heater (Ambulance).	2-66c
12	Brake pedal, master cylinder, brake linings	Check service brake pedal for proper travel. Check handbrake linkage for proper adjustment. Check master cylinder fluid level. Inspect brake lining thickness. Note uneven lining wear from wheel to wheel.	2-10e 2-102b 2-104a
13	Clutch.	Check that clutch pedal has proper free travel and that action of pedal return spring is satisfactory.	2-31
14	Battery-specific gravity	Clean top of battery. Use hydrometer to test electrolyte in each cell of both batteries. Record results on DA Form 2404.	2-66b
15	Carburetor air cleaner	Check carburetor air cleaner to determine if air cleaner element requires cleaning or replacement.	2-36d
16	Fuel tank strainer and fuel lines	Clean strainer in fuel tank pipe. Check fuel lines for looseness. Visually check that fuel tank attaching straps are secure.	
17	Power take-off and winch.	Inspect power take-off, winch drive shaft and shearpin for damage. Check winch operation. Check that vent in winch worm gear housing is free of obstructions.	3-56
18	Bumpers, pintles and towing shackles.	Check front and rear towing shackles, bumpers, and pintle for serviceability. Check operation of pintle and note whether it locks securely.	
19	Propeller shaft and universal joints	Inspect propeller shaft for looseness and damage. Inspect universal joints and companion flange bolts for looseness and damage.	2-88
20	Wheels and studs.	Inspect wheels for cracks and damage. Check wheel and drum flange stud nuts for looseness and damage.	2-110d
21	Springs and shock absorbers.	Inspect springs, shackles, shock absorbers and attaching parts for damage, breakage and leakage.	
		Road Test	
22	Starter.	While starting engine, check that starter engages smoothly without unusual noise, and engine cranks with adequate speed.	
23	Instruments.	While warming up engine, check and observe instrument operation. Battery alternator indicator should indicate alternator is charging. Oil pressure indicator should indicate 10 lb. oil pressure at 600 rpm. Water temperature should slowly rise and register. Fuel quantity indicator should indicate fuel level.	

24	Engine operation.	While warming up engine, check choke operation. Check that idling speed is normal. Listen for any unusual noises at idle and higher speeds. When operating vehicle, note if it has normal power and acceleration in each speed range. Listen for any unusual noises when engine is under load.	2-36
25	Alternator	Listen for unusual noises.	
26	Clutch.	Check that clutch disengages completely without a tendency to drag. Check for smoothness of engagement, any tendency to drag, grab, continued chatter, slip or for any unusual noise. With transmission in neutral, depress and release clutch pedal while listening for noises that indicate defective release bearing.	2-31
27	Transmission and transfer	Shift transmission into all speeds and transfer into all ranges, while checking for any unusual shift stiffness, tendency to slip out of gear, unusual noises or excessive vibrations.	
28	Service and handbrake operation	Check that brake pedal return spring action is satisfactory. Check that pedal does not go too close to floor. Make several stops, noting side pull, noise, chatter, grabbing or any other abnormal condition. Stop vehicle on an incline and apply hand-brake to determine if it holds vehicle. Check that handbrake ratchet holds.	2-102a
29	Steering system	With vehicle moving straight ahead, determine if there is any tendency to wander, shimmy or pull to one side. Turn steering wheel through entire range and note any binding.	
30	Power train, wheels and body.	At all times during road test, be alert for unusual noises that may indicate looseness, defects, or deficient lubrication at any point.	
		AFTER ROAD TEST	
31	Hubs, drums, axles, power train.	Immediately after road test check cited units for excessive temperature. If lubrication levels are correct and no unusual noises occurred during road test, assume axles are functioning properly. An overheated wheel hub and brake drum may indicate an improperly adjusted, defective or dry wheel bearing, or a dragging brake. An abnormally cool condition indicates an inoperative brake. An overheated gear case indicates lack of lubrication, gears out of adjustment, or defective part	2-107 2-102a
32	Manifolds.	Inspect for evidence of leakage.	

33	Vehicle exhaust system and fuel burning personnel heater	Inspect exhaust system for leakage and excessive noise. Tighten mountings. On ambulance, operate patient compartment heater. Check exhaust system for leakage. Check floor and side panels for evidence of exhaust leakage into patient compartment.	
34	Vents and leakage.	Check under vehicle for evidence of oil water, hydraulic fluid, or lubricant leakage. Check that vents in front and rear axles, transfer case and steering gear housing are clear.	
35	Clean.	Wash vehicle, clean inside of cab, glass and mirror. Clean engine and engine compartment as required. Do not steam clean.	
36	Lubricate	Lubricate in accordance with Lubrication Order, LO 9-2320-244-12.	
37	Fuel	Fuel vehicle in accordance with unit SOP.	
38	Test.	Perform final road test with particular attention to items that required repair, replacement or adjustment.	
		6000 Miles or 6 Months	
39	3000 mile scheduled maintenance	Perform procedures for 3000 mile scheduled maintenance.	
40	Carburetor, choke linkage.	Check that shafts and linkage operate freely and are not excessively worn. Remove air cleaner extension and check that choke valve opens fully	
41	Body and frame	Check all chassis and body bolts for looseness.	
42	Fuel filter.	Replace the fuel filter element and if excessive contamination is noted, drain approximately one quart of fuel and contaminates from the fuel tank. Dispose of this fuel in a safe manner. Do not reuse it or dump it down a drain.	2-37c
		12,000 Miles or 12 Months	
43	6,000 mile scheduled maintenance.	Perform procedures for 6,000 mile scheduled maintenance. Items 44 through 46 will be added to the After Road Test portion of the 6,000 mile scheduled maintenance.	
44	Front axle universal joints	Drain and refill front axle universal joints as directed by current lubrication order LO 9-2320-244-12.	
45	Positive crank-case ventilation valve.	Remove and replace positive crankcase ventilation valve. Inspect hoses and fittings; clean and replace as required.	2-37d
46	Clean and oil winch cable.	Unwind winch cable; clean it with a wire brush and non-flammable solvent. Oil cable thoroughly with CW-11C lubricating oil.	3-4

Section V. TROUBLESHOOTING THE VEHICLE

2-13. General.

- a. This section contains troubleshooting information and tests for locating and correcting troubles which may develop in the vehicle. Each symptom of trouble or malfunction given for an individual unit or system is followed by a list of probable causes of the trouble and corrective actions necessary to remedy the malfunction.
- b. This manual cannot cover all possible troubles and malfunctions that may occur under the many conditions of operation. If a specific malfunction is not covered, proceed to isolate the system in which the trouble occurs and then isolate the defective component. Use all of the senses to observe and locate troubles. Do not neglect use of test instruments that are available. Standard automotive theories and principles of operation apply in troubleshooting these vehicles. Question the driver to obtain maximum number of observed malfunctions. The greater the number of malfunctions that can be evaluated, the easier it will be to isolate the defect.
- c. The tests and remedies provided in this section are governed by the scope of the organizational level of maintenance. This troubleshooting section should be used as a supplement to the troubleshooting section contained TM 9-2-20-244-10.

2-14. Troubleshooting Table.

- a. Table 2-3 lists possible malfunctions that may occur in the vehicle or in components or systems of the vehicle. Each malfunction is followed by a list of probable causes that must be considered in determining corrective action.
- b. Where electrical malfunctions occur, only correction of minor and obvious causes are listed in table 2-3. All other electrical malfunctions are covered in Section VI, Troubleshooting the Electrical System.
- c. Information in this section is for use by organizational maintenance personnel in conjunction with, and as a supplement to the troubleshooting section in the Operator s Manual, TM 9-2320-244-10. It provides continuation of instructions when a remedy in the operator s manual refers to Organizational Maintenance for corrective action.

TABLE 2-3. Troubleshooting

MALFUNCTION	PROBABLE CAUSE	CORRECTIVE ACTION
	ENGINE	
1. Engine fails to crank or cranks slowly.	a. Faulty batteries or cables.	a. Check for loosened cables or connectors at battery, battery to starter connection, battery to engine ground cable, or the engine to frame cable.
	b Incorrect oil viscosity (cold weather only).	b. Inspect engine oil. Drain and fill with correct grade as specified in lubrication order LO 9-2320-244-12
	c Defective starter system	c Troubleshoot starting system See Section VI
	d. Mechanical seizure of parts.	d. Notify support maintenance.

2. Engine cranks but fails to start.	a. Combustion chamber flooded with fuel.	a. If choke has been used excessively, fuel may flood the combustion chamber. Push choke all the way in, hold accelerator pedal to floor and crank engine to clean out excessive fuel. If flooding continues, troubleshoot fuel system
	b Current not reaching spark plugs	b Troubleshoot ignition system
	c. Inoperative fuel pump.	c. Test fuel pump (para 2-36b).
	d. Incorrect ignition timing.	d. Adjust ignition timing (para 2-51c).
3. Engine starts but fails to keep running.	a. Engine idle speed set too low,	a. Adjust idle speed (para 2-36a).
	b. Defective fuel pump.	b. Check fuel pump (para 2-36b).
	c. Choke not operating properly.	c. Check choke linkage and correct any binding condition, or replace damaged linkage (Para 2-37g).
	d. Defective carburetor.	d. Replace carburetor (Para 2-37e).
	e. Inoperative fuel pump or low oil level in crankcase.	e. Check engine oil level. Add oil if necessary. Troubleshoot fuel pump.
	f. Defective spark plugs.	f. Check spark plugs (para 2-51b).
4. Engine runs, but misses	a. Defective ignition distributor	a. Troubleshoot ignition distributor.
	b. Improper choke operation.	b. Check choke linkage and correct any binding condition, or replace damaged linkage.
	c. Low or erratic fuel pump pressure.	c. Check fuel pump pressure (para 2-36b), fuel pump system. If fuel pressure is not within specified limits, replace fuel pump (para 2-37b).
	d. Defective carburetor.	d. Replace carburetor (para 2-37e).
5. Poor accelerator.	a. Incorrect ignition timing.	a. Troubleshoot ignition system. Refer to Electrical Troubleshooting Charts.
	b. Fouled or improperly adjusted spark plugs.	b. Inspect spark plugs (para 2-26f).
	c. Ignition distributor not advancing properly.	c. Troubleshoot ignition system.
6. Lack of power.	a. Engine over heating.	a. Troubleshoot cooling system (items 12 through 14).
	b. Choke not fully open.	b. Push choke control rod all the way in. Adjust cable if necessary.

	c. Fuel system restricted.	c. Troubleshoot fuel system (items 15 through 18).
	d. Improper valve adjustment.	d. Notify support maintenance.
	e. Valves sticking.	e. Notify support maintenance.
7. Engine will not idle.	a. Carburetor out of adjustment.	a. Adjust carburetor (para 2-36a).
	b. Air leaking into intake manifold.	b. Apply a small amount of oil at carburetor and intake manifold flanges. If oil is sucked into manifold, air leak is present. Notify support maintenance.
8. Excessive oil consumption.	a. External leaks.	a. Inspect oil pan and oil filter for leaks. If oil leaks, notify support maintenance.
	b. Crankcase overfilled	b. Drain oil to correct oil level (LO 9-2320-244-12).
	c. Piston rings worn, stuck, or broken.	c. Test compression to verify cause (para 2-26d). Notify support. Maintenance
	d. Crankcase vents not operating properly	d. Check for inoperative crankcase metering valve. Clean or replace as required (para 2-37d).
9. Sharp knock or ping (a sharp metallic knock occurring on acceleration or when operating under heavy load)	a. Ignition timing too early for fuel used.	a. Check ignition timing, electrical troubleshooting procedure.
	b. Engine overheating.	b. Troubleshoot cooling system (items 12 through 14).
	c. Improper spark plugs.	c. Install correct spark plugs.
10. Valve noise.	All causes.	Notify support maintenance.
11. Low or no oil pressure.	Oil low in crankcase	Check engine oil and grade. Refer to lubrication order. Crankcase should be properly filled with oil of correct grade. If correct level and grade of oil are found, low oil pressure may be caused by worn engine parts. Notify support maintenance.
	COOLING SYSTEM	
12. Engine overheats	a. Cooling system has low coolant level	a. Replenish coolant. Fill to a level slightly below the bottom of the radiator filler neck. Add antifreeze solution as required.
	b. Loose or worn drive belts.	b. Adjust belt tension or replace belts (para 2-46j).
	c. Clogged cooling system.	c. Clean cooling system.

	d. Faulty thermostat.	d. Remove and test thermostat, Replace if faulty (para 2-47c).
	e. Leaks in cooling system.	e. Inspect cooling system for leaks, paying particular attention to hose or radiator connections. Replace hose or leaking radiator (para 2-47).
	f. Incorrect ignition timing.	f Check ignition timing, electrical troubleshooting procedure.
	g. Clogged muffler or exhaust pipes	g. Replace muffler, or exhaust outlet pipe (para 2-42)
	h Air flow obstructed through	h Remove obstructions to allow radiator unrestricted flow of air
	i Excessive friction in power train	i Check brake systems and power train components for binding
	j. Inoperative water pump.	j. Replace water pump (para 2-47e).
13. Loss of coolant.	a. Hose leaks.	a. Tighten clamps or replace hose.
	b. Drain plug leak.	b. Tighten or replace drain plug.
	c. Cylinder head gasket leak.	c. Notify support maintenance.
	d. Radiator cap inoperative.	d. Replace cap.
	e. Water pump or radiator core leaks.	e. Replace water pump (para 2-47e) or radiator (para 2-47b).
	f Cracked cylinder head or block.	f. Notify support maintenance.
14. Engine fails to reach normal operating temperature.	a. Defective or incorrect thermostat installed in vehicle	a. Inspect and test thermostat. Replace if defective or incorrect heat range (para 2-47c).
	b. Temperature sending unit defective	b. Troubleshoot temperature indicator and sending unit.
	c. Temperature indicator defective.	c. Same as above.
	FUEL SYSTEM	
15. Fuel does not reach carburetor.	a. Fuel tank empty.	a. Fill tank with proper grade fuel.
	b. Fuel line leak.	b. Tighten connector at leak; if line still leaks replace defective parts (para 2-37b).
	c. Fuel filter clogged.	c. Replace filter.
	d. Fuel pump pressure low.	d. Troubleshoot fuel pump system.
	e. Fuel lines clogged.	e. Clean lines.
	f Defective fuel pump.	f Replace fuel pump.

16. Fuel does not reach cylinders.	a. Choke does not close	a. Remove air cleaner hose. Pull out choke control rod and note whether choke valve closes at carburetor. If not, connect or adjust linkage (para 2-36 g).
	b. Carburetor fuel passages clogged.	b. If fuel reaches carburetor and choke closes properly, replace carburetor (para 2-39b).
17. Engine floods	a. Carburetor choke control not fully open.	a. Remove air intake hose at carburetor. Push choke control all the way in. Look into carburetor to make certain choke control valve is fully open. If not fully open, adjust (para 2-36g).
	b. Fuel pump pressure incorrect.	b. Check fuel pump pressure (para 2-36b).
	c. Worn carburetor or float valve stuck.	c. If engine continues to flood after procedures a and b above have been performed, replace carburetor (para 2-39b)
18. Excessive fuel consumption.	a. Leaks.	a. Carefully inspect all fuel lines and fittings for leaks. Tighten or replace damaged lines or fittings (para 2-37b).
	b. Carburetor choke control not fully open.	b. Refer to item 17a.
	c. Carburetor adjustment incorrect.	c. Adjust carburetor (para 2-36a).
	d. Air cleaner restricted or dirty.	d. Service air cleaner (para 2-36d).
	e. Spark plugs dirty or incorrectly adjusted.	e. Remove spark plugs (para 2-52d). Clean and set plug gap at .020 inch.
	f. Fuel pump pressure incorrect	f Check fuel pump pressure (para 2-36b).
	g Incorrect ignition timing	q Check ignition timing (para 2-51c)
	h Incorrect valve adjustment	h Perform manifold vacuum test (para 2-26e).
	i. Brakes drag.	i. Adjust brakes (para 2-102a).
	j. Cylinder compression poor or or uneven.	j. Perform cylinder compression test (para 2-26d). If compression is poor or uneven, notify support maintenance.
	k. Carburetor fuel float adjustment incorrect.	k. Replace carburetor (para 2-39b).

EXHAUST SYSTEM		
19. Unusual noise.	a. Break or crack in exhaust	a. Inspect muffler for breaks or muffler cracks. If muffler is unserviceable, replace (para 2-42d).
	b. Loose or damaged connections.	b. Inspect exhaust system for broken brackets or leaking gaskets. Replace damaged parts as required (para 2-42).
20. Exhaust system restricted.	Muffler outlet pipe or pipes plugged.	Repair or replace pipe. (Para 2-42).
CLUTCH		
21. Clutch chatter.	a. Binding of clutch release linkage	a. Clean and free linkage.
	b. Loose engine mounts.	b. Tighten engine mounts (para 2-245)
	c. All other causes.	c. Notify support maintenance.
22. Clutch grabbing.	a. Release linkage binding	a. Clean and free linkage.
	b. All other causes	b. Notify support maintenance.
23. Clutch slipping	a. Lack of pedal free play.	a. Adjust pedal free play (para 2-31).
	b. Release linkage binding.	b. Clean and free linkage.
	c. All other causes.	c. Notify support maintenance.
24. Clutch dragging,	a. Excessive pedal free play.	a. Adjust pedal free play (para 2-31).
	b. All other causes.	b. Notify support maintenance.
TRANSMISSION		
25. Hard gear shifting.	a. Too much clutch pedal free play.	a. Adjust pedal free play (para 2-31).
	b. Clutch disk or other clutch parts damaged.	b. Notify support maintenance.
26. Slips out of gear.	Transmission parts worn or damaged.	Notify support maintenance.
27. Engagement of two speeds.	Transmission cover parts worn or damaged.	Notify support maintenance.
28. Lubricant leakage.	a. Lubricant level too high in transmission.	a. Drain to proper level. Refer to LO 9-2320-244-12.
	b. Leak at bearing retainer capscrew.	b. Remove screw, dip in white lead or paint, and install.

	c. Drain plug loose or damaged.	c. Tighten or replace drain plug.
	d. Transmission input shaft seal leaking.	d. Notify support maintenance.
	e. Transmission expansion plugs loose	e. Notify support maintenance.
	f. Transmission cover gasket leaking.	f. Tighten cover mounting bolts
29. Transmission noisy.	a. Loose mounting bolts	a. Tighten loose bolts.
	b. Flywheel housing alignment incorrect.	b. Notify support maintenance.
	c. Insufficient lubricant.	c. Fill with proper lubricant
	d. Worn or damaged parts.	d. Notify support maintenance.
	TRANSFER CASE	
30. Transfer will not shift into gear.	a. Incorrect lubricant	a. Refer to LO 9-2320-244-12.
	b. Transfer worn or damaged.	b. Notify support maintenance.
31. Transfer slips out of gear.	Damaged or worn parts.	Notify support maintenance.
32. Transfer noisy in operation.	a. Insufficient lubrication	a. Check the transfer case lubricant level. Refer to LO 9-2320-244-12.
	b. Incorrect lubricant.	b. Refer to LO 9-2320-244-12.
	c. Transfer parts worn or damaged.	c. Notify support maintenance.
33. Transfer leaks lubricant.	a. Drain plug loose damaged.	a. Tighten or replace drain plug.
	b. Damaged transfer input, output, or shifter shaft oil seal.	b. Notify support maintenance.
	c. Case cracked.	c. Notify support maintenance.
34. Hard shifting out of front axle drive	Torsional windup between front and rear propeller shafts.	Drive a short distance in a straight line, preferably on dirt or gravel.
	PROPELLER SHAFTS	
35. Backlash or noise in joint.	Damaged or worn bearings.	Repair universal joint (para 2-87).
36. Vibration in propeller shaft.	Worn or damaged universal joint or propeller shaft sprung.	a. Repair universal joint (para 2-87), and/or replace propeller shaft (para 2-86).
	b. Loose attaching bolts or nuts.	b. Check attaching bolt torque.
	AXLES	
37. Front axle assembly, unusual noise.	a. Insufficient lubricant	a. Lubricate in accordance with LO 9-2320-244-12.

	b. Front wheel bearings worn or incorrectly adjusted.	b. Adjust or replace bearings (para 2-108).
	c. Wheel drive shaft universal joint worn, loose, or damaged.	c. Notify support maintenance.
	d. Worn or damaged differential.	d. Notify support maintenance.
38. Rear axle assembly, unusual noise.	Same as front axle, item 37 above.	Same as front axle, item 37 above.
39. Axle leaks lubricant	a. Pinion oil seal damaged.	a. Notify support maintenance.
	b. Differential housing or cover gasket leaking.	b. Notify support maintenance.
40. Excessive backlash (play).	a. Worn or damaged differential.	a. Notify support maintenance.
	b. Differential bearings out of adjustment.	b. Notify support maintenance.
	c. Loose universal joint flanges.	c. Tighten or replace flanges.
	SERVICE BRAKES	
41. One brake drags.	a. Distorted or improperly adjusted brakeshoes.	a. Inspect brakeshoe and adjust or replace as necessary (paras 2-102 and 2-103)
	b. Faulty retracting spring.	b. Replace retracting spring (para 2-103a).
	c. Brakedrum out-of-round.	c. Replace brakedrum (para 2-108).
	d. Faulty wheel cylinder.	d. Replace wheel cylinder (para 2-103c).
	e. Improperly adjusted or damaged wheel bearing.	e. Adjust or replace wheel bearings (para 2-108).
	f. Brake line restricted.	f. Replace or clean affected brake line.
42. All brakes drag.	a. Pedal improperly adjusted.	a. Adjust brake pedal (para 2-102e).
	b. Distorted or improperly adjusted brakeshoe.	b. See item 41a above.
	c. Brake line restricted	c. See item 41f above.
	d. Faulty master cylinder.	d. Replace master cylinder (para 2-103c).
43. Hard pedal.	a. Pedal linkage to master cylinder binding	a. Free binding or repair or replace damaged portion of linkage.
	b. Glazed or worn brake linings.	b. Replace brakeshoe assemblies (para 2-103a).
	c. Brake line restricted.	c. See item 41f above.
	d. Distorted or improperly adjusted brakeshoes.	d. See item 41a above.

44. Spongy pedal.	a. Brake line restricted	a. Replace or clean affected brake line.
	b. Air in hydraulic system.	b. Bleed brake system (para 2-102d).
	c. Insufficient hydraulic fluid.	c. Fill master cylinder with proper fluid.
45. Vehicle pulls to one side when brakes are applied	a. Improper tire pressure.	a. Refer to vehicle data plate for proper tire pressure.
	b. Distorted or improperly adjusted brakeshoes.	b. See item 41a above.
	c. Glazed or worn brake linings.	c. See item 43b above.
	d. Brakedrum out-of-round.	d. See item 41c above.
	e. Oil, grease, or brake fluid on linings	e. Inspect brake linings (para 2-104) and replace if necessary.
	f. Faulty retracting spring.	f See item 41b above.
	g. Faulty wheel cylinder.	g. See item 41d above
	h. Worn wheel bearings.	h. Adjust or replace wheel bearings (paras 2-107 or 2-108).
	i. Improperly adjusted wheel bearings.	i. Adjust wheel hearings (para 2-107).
	j. Brake line restricted.	j. See item 41f above.
	k. Loose suspension.	k. Check suspension parts
46. One wheel locks	a. Distorted or improperly adjusted brakeshoe.	a. See item 41a above.
	b. Oil, grease, or brake fluid on lining.	b. See item 45e above.
	c. Front wheel locks on turn.	c. Check turn stop adjustment. Notify support maintenance.
47. Brake chatter	a. Brakedrum out-of-round.	a. See item 41c above.
	b. Glazed or worn brake linings.	b. See item 43b above.
	c. Oil or grease on brake linings	c. See item 45e above.
	d. Loose brake linings.	d. Inspect brake linings. Replace brakeshoe assemblies (para 2-103).
48. Excessive pedal travel	a. Brakes out of adjustment.	a. Adjust brakes (para 2-102a).
	b. Insufficient hydraulic fluid	b. See item 44c above.
	c. Leaks in hydraulic system.	c. Bleed brake system (para 2-102d).
	d. Glazed or worn brake linings.	d. See item 43b above.
49. Pedal gradually goes to floor	a. Insufficient hydraulic fluid.	a. See item 44a above.
	b. Leaks in hydraulic system.	b. See item 48c above.
	c. Faulty master cylinder	c. See item 42d above.

50. Brakes uneven	a. Scored brakedrum.	a. Replace breakdrum (para 2-108d).
	b. Incorrect adjustment.	b. Adjust brakes (para 2-102a)
51. Brakes grab.	a. Distorted or improperly adjusted brakeshoes.	a. See item 41a above.
	b. Glazed or worn brake linings.	b. See item 436 above.
	c. Oil, grease or brake fluid on brake lining.	c. See item 45e above
	d. Scored brakedrum.	d. See item 50a above.
	e Dirt on drum or lining surface	e Inspect and clean brakedrum and shoe assemblies (para 2-104a).
	f. Faculty wheel cylinder.	f See item 41d above.
52. Brakes fail completely	a. Insufficient hydraulic fluid.	a. See item 44a above.
	b. Leaks in hydraulic system.	b. See item 48c above.
	c. Air in hydraulic system.	c. See item 445 above.
	d. Faulty master cylinder.	d. See item 42d above.
	e. Linkage from pedal to master cylinder disconnected or broken.	e. Free binding or repair or replace damaged portion of linkage
	f. Damage to hydraulic components	f Incorrect type of fluid. Drain, flush, and replace with nonpetroleum base fluid (LO 9-2320-244-12)
	PARKING BRAKE	
53. Parking brake does not hold.	a. Brake shoes improperly adjusted.	a. Adjust (para 2-102b).
	b. Brake lining worn or damaged.	b. Replace band and lining (para 2-103b). Also inspect drum. Replace drum if necessary (para 2-103b).
	c. Components coated with dirt or other contaminant.	a. Clean components if possible, replace parts as necessary
	d. Brake linkage damaged.	d. Replace damaged linkage.
54. Parking brake drags and overheats.	a. Brake partially applied	a. Release lever fully.
	b. Shoes improperly adjusted.	b. Adjust (para 2402b).
	c. Lining loose and damaged.	c. Replace band and lining (para 2-103b).

	WHEELS AND TIRES	
55. Abnormal tire wear.	a. Continual use of four-wheel drive on hard surface roads and at speeds in excess of 25 mph.	a. Use four-wheel drive only when maximum traction is needed.
	b. Tire pressure incorrect.	b. Correct tire pressure. (Refer to vehicle data plate).
	c. Improper toe-in.	c. If wear is in front tires adjust toe-in (para 2-92). If wear is in rear tires check rear suspension for damage.
	d. Wheels, tires, or brakedrums out of balance.	d. Replace as necessary.
56. Wheel wobbles.	a. Bent wheel.	a. Replace wheel.
	b. Wheel bearings out of adjustment or damaged.	b. Adjust bearings (para 2-107). Notify support maintenance if wheel misalignment is suspected.
	STEERING	
57. Backlash in steering	a. Pitman arm loose	a. Tighten pitman arm nut (para 2-95d).
	b. Worn or damaged parts in steering gear.	b. Notify support maintenance
58. Erratic steering	a. Incorrect front wheel alignment.	a. Adjust toe-in (para 2-92). If condition persists, notify support maintenance.
	b. Incorrect steering gear adjustment.	b. Notify support maintenance.
	c. Loose steering linkage.	c. Tighten all loose connections.
	d. Incorrect front wheel bearing adjustment.	d. Adjust wheel bearings (para 2-107).
59. Hard steering	a. Incorrect tire pressure.	a. Inflate tires to proper pressure. (Refer to vehicle data plate).
	b. Tires not of uniform size.	b. Install tires of uniform size.
	c. Lack of lubrication,	c. Lubricate in accordance with LO 9-2320-244-12.
	d. Incorrect steering adjustment.	d. Notify support maintenance.
60. Shimmy.	a. Incorrect tire pressure.	a. Inflate tires to proper pressure. (Refer to vehicle data plate).
	b. Incorrect front wheel alignment.	b. Check toe-in (para 2-92).
	c. Incorrect steering gear adjustment.	c. Notify support maintenance.
	d. Tires not of uniform size.	d. See item 59b. If condition persists notify support maintenance.
	e. Loose steering linkage.	e. Tighten steering linkage.
	f. Incorrect front wheel bearing adjustment.	f. Adjust wheel bearings (para 2-107)

	g. Weak front shock absorber	g. Replace front shock absorber (para 2-93a).
	h. Bent or worn spindle.	h. Notify support maintenance.
	i. Spring clip bolts loose.	i. Tighten loose bolts.
	j. Steering knuckle ball seal worn	j. Notify support maintenance
	k. Bent wheel.	k. Replace wheel.
61. Pull to one side	a. Incorrect tire pressure.	a. Inflate tires to proper pressure. (Refer to vehicle data plate).
	b. Incorrect front wheel alinement.	b. Adjust toe-in (para 2-92).
	c. Tires not of uniform size.	c. See item 59b; if condition persists notify Support maintenance.
	d. Unequal brake adjustment.	d. Adjust service brakes (para 2-102a)
	e Incorrect front wheel bearing adjustment.	e Adjust wheel bearing (para 2-107).
	f Bent spindle arm.	f Replace spindle arm (para 2-93c).
	g. Sagging or broken suspension front spring.	g. Replace suspension front spring (para 2-93c).
62. Wander; body sway.	a. Incorrect tire pressure.	a. Inflate tires to proper pressure. (Refer to vehicle data plate).
	b. Tires not of uniform size.	b. Refer to item 59b.
	c. Loose steering linkage.	c. Tighten steering linkage.
	d. Incorrect steering gear adjustment.	d. Notify support maintenance.
	e. Loose steering gear mounting bolts	e. Tighten steering gear mounting bolts.
	f Incorrect front wheel alinement	f Adjust toe-in (para 2-92)
	g. Defective shock absorbers	g. Replace shock absorbers (para 2-93a and 2-98a).
63. Tires squeal on turns	a. Incorrect tire pressure.	a. Inflate tires to pressure. (Refer to vehicle data plate).
	b. Incorrect front wheel alinement	b. Adjust toe-in (para 2-92).
	c. Bent spindle arm.	c. Replace spindle arm (para 2-93c)
	SPRING AND SHOCK ABSORBERS	
64. Spring breakage.	a. Extremely rough handling of a vehicle over rough terrain	Reduce vehicle speed over rough terrain when possible.
	b. Lack of shock absorber control.	b. Replace shock absorbers (para 2-93a or 2-98a).
65. Poor recovery or slow action	a. Shock absorber bushing binding or damaged.	a. Replace shock absorbers (para of shock absorbers 2-93a or 2-98a).

	b. Lack of shock absorber control.	b. Replace shock absorbers (para 2-93a and 2-98a).
	c. Loose mountings.	c. Check insulators. If serviceable, tighten shock absorber mounting nuts.
66. Lack of spring control.	a. No fluid in shock absorbers.	a. Replace shock absorber (para 2-93a and 2-98a).
	b. Shock absorbers inoperable.	b. Replace shock absorber (paras 2-93a and 2-98a)
	CRANKCASE VENTILATION SYSTEM	
67. Erratic idling	a. Defective metering valve	a. Clean metering valve (para 2-36d).
	b. Leak or hole in line or fitting.	b. Replace defective line or fitting.

Section VI. TROUBLESHOOTING THE ELECTRICAL SYSTEM

2-15. General.

a. This section contains troubleshooting information to aid in locating and correcting malfunctions in the electrical system. The following methods are used to cover each of the functional system circuits.

- (1) A physical and functional description.
- (2) A brief overall system check to determine if the complete system is operating properly.
- (3) An illustration showing the location on the vehicle of the major components of the system.
- (4) Step-by-step tests to diagnose trouble, using authorized test equipment.

b. This section also includes a list of electrical circuit numbers with a brief description of each, and a complete vehicle circuit diagram.

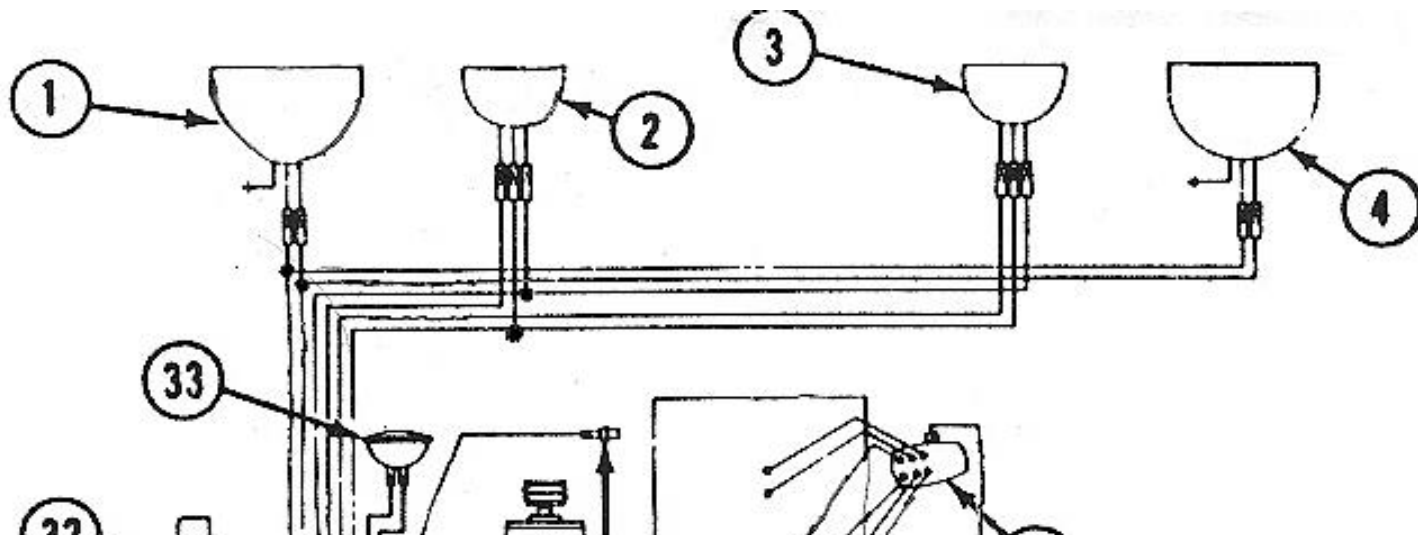

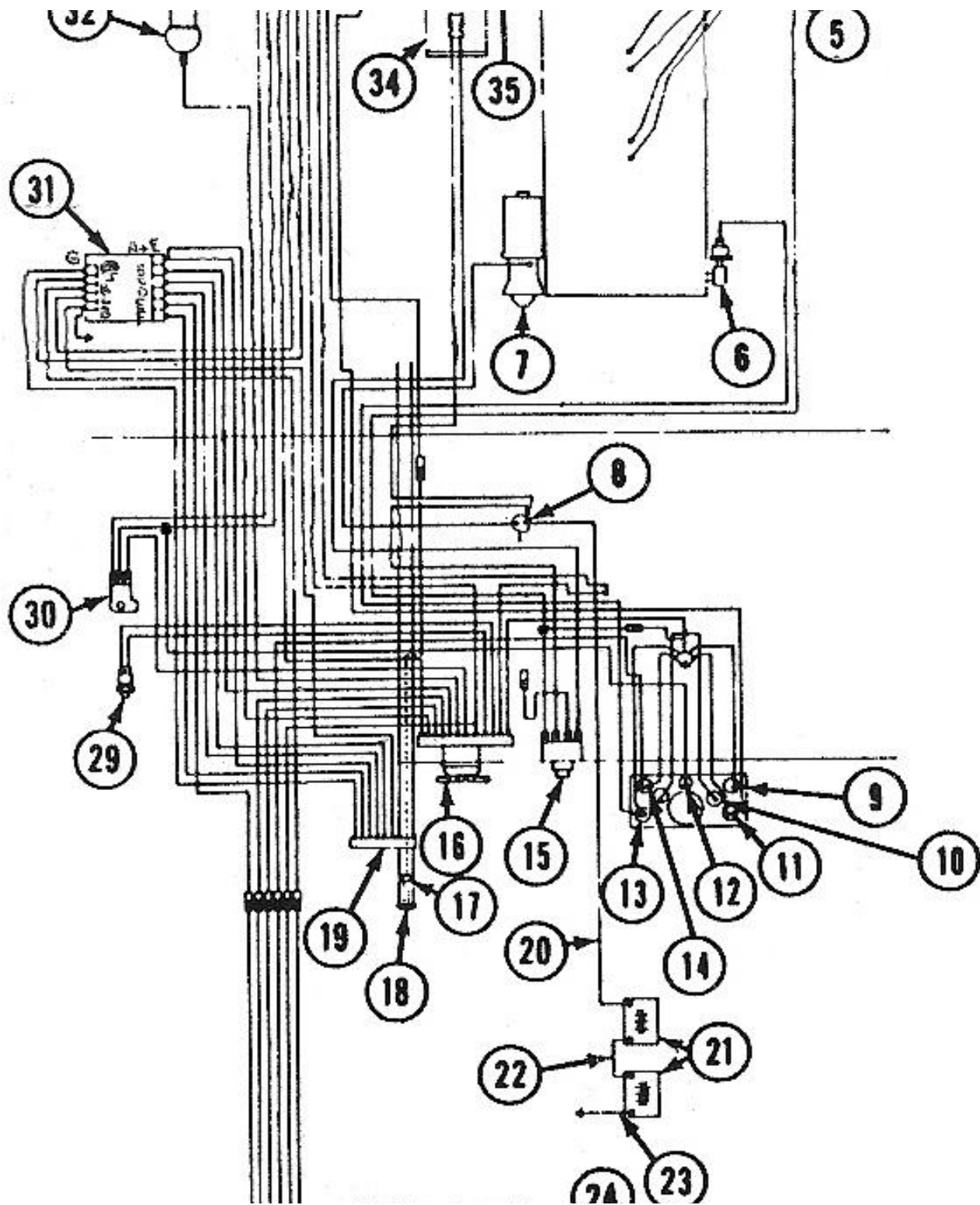

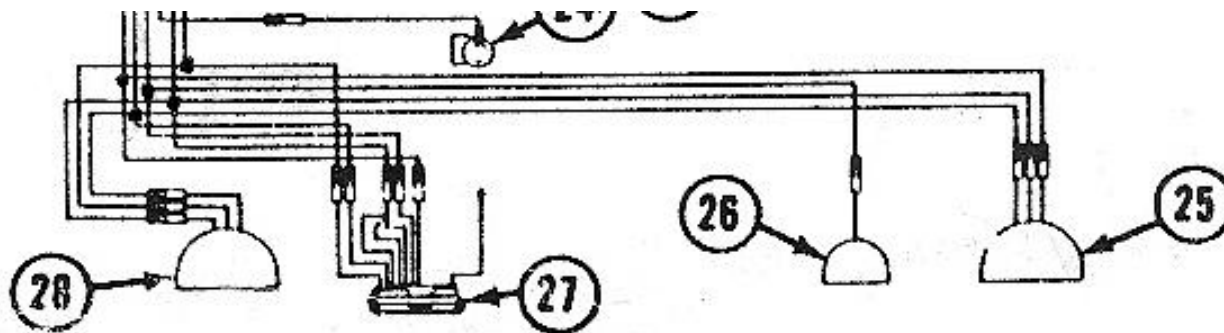

FIGURE 2-2 Vehicle Wiring Diagram, M715

1 LEFT HEADLAMP (17,19)	18 HORN BUTTON (25)
2 LEFT BLACKOUT MARKER LAMP (20)	19 DIRECTIONAL SIGNAL SWITCH (460, 461, 22-460, 22-461)
3 RIGHT BLACKOUT MARKER LAMP (20)	20 BATTERY FEED TO FOOT STARTER SWITCH (82)
4 RIGHT HEADLAMP (17, 19)	21 BATTERIES
5 IGNITOR (12)	22 BATTERY INTERCONNECTING CABLE (68)
6 OIL PRESSURE SENDING UNIT (36)	23 BATTERY GROUND (7)
7 STARTING MOTOR (6)	24 FUEL GAUGE TANK UNIT (28, 79)
8 FOOT STARTER SWITCH (82)	25 RIGHT TAIL LAMP
9 BATTERY GENERATOR INDICATOR (27)	26 BLACKOUT STOP LAMP (23)
10 PANEL LIGHT (40)	27 TRAILER COUPLING RECEPTACLE (M715) (90)
11 TEMPERATURE GAUGE (33)	28 LEFT TAIL LAMP (21)
12 HI-BEAM INDICATOR (17)	29 STOPLIGHT SWITCH (75)
13 OIL PRESSURE GAUGE (36)	30 HEADLIGHT SELECTOR SWITCH (16, 17, 18)
14 FUEL LEVEL GAUGE (28)	31 DISTRIBUTION BOX GROUND (GRD)
15 IGNITION SWITCH (11)	32 BLACKOUT DRIVING LAMP (19)
16 LIGHT SWITCH (15)	33 HORN FEED (25A)
17 HORN SWITCH (25)	34 ALTERNATOR (5, 468)
	35 TEMPERATURE SENDING UNIT (33)

WARNING

Because of their higher power capabilities, 24-volt systems are more dangerous than 6 or 12 volt systems. Certain precautions must be observed before beginning any tests on the 24 volt system. Do not permit a hot wire to touch metal parts of the vehicle at any time. Flash testing by striking a hot wire against a vehicle ground will cause an arc that may completely destroy the connector on a conductor. Accidental contact of metal tools between battery or starter cables and the frame of the vehicle causes direct short Circuit which may result in arcing and instant heating of the tool to a red hot heat condition. This can cause painful burns on the hands and serious damage to tools, vehicle components and batteries. Moreover, the overloaded

battery may explode, spraying hot acid and sharp fragments over the surrounding area. The correct procedure when removing electrical equipment, harnesses, battery cables or starter cables, is to disconnect the battery ground cable first. Protect the ground cable from accidental contact with the battery positive terminal by wrapping the ground cable terminal liberally with non-hygroscopic tape. When the work has been completed, connect the battery ground cable last.

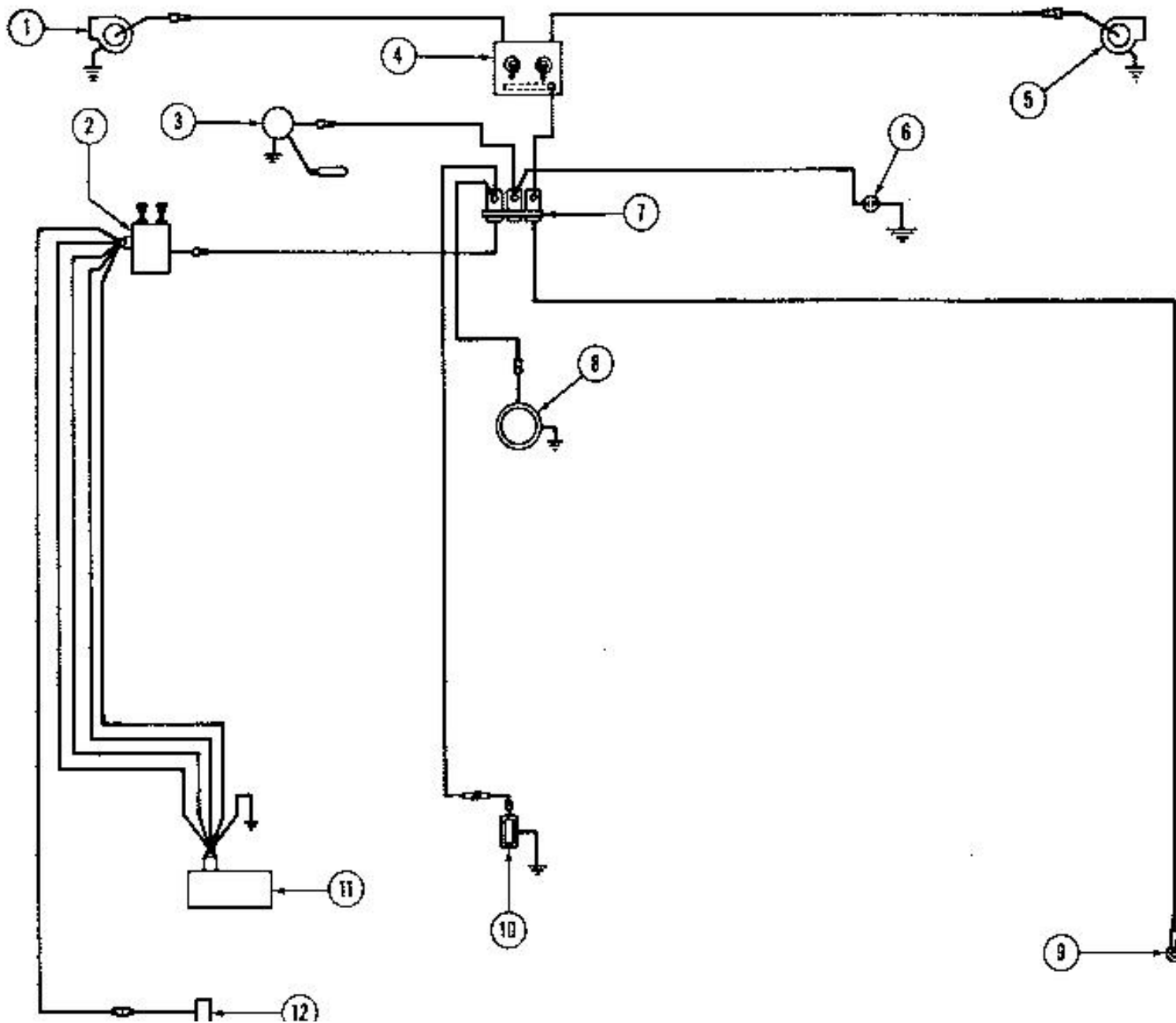

FIGURE 2-3 Ambulance Body Wiring Diagram

1 Blower Assembly (left) (411)	7 Circuit Breaker (10)
2 Heater Control (400)	8 Surgical Light (38)
3 Spot Light (87)	9 Battery Terminal Lug (10)
4 Blower Switches (411)	10 Dome Light (38)
5 Blower Assembly (right) (411)	11 Heater (400)
6 Resuscitator receptacle (40)	12 Fuel Pump (400)

2-16. System Circuits.

a. To successfully troubleshoot the electrical system, analyze the entire system as follows:

- (1) Attempt to isolate the system in which the malfunction occurs.
- (2) Isolate the circuit within the system that is not working.
- (3) Isolate the individual component within the circuit that is causing the trouble.

b. Question the vehicle operator to obtain the maximum number of observed symptoms. The greater the number of trouble symptoms that can be evaluated, the easier it will be to isolate the primary cause of a defect. Since the operator of the vehicle, in most instances, can describe malfunctions only in terms of unsatisfactory vehicle performance, trained personnel should be capable of analyzing the operational symptoms to determine the primary cause of the malfunction.

c. The functional system circuits covered in this section are in the following sequence:

Circuit	Table
(1) Starting System Circuit	2-4
(2) Charging System Circuit	2-5
(3) Ignition System Circuit	2-6
(4) Lighting System Circuit	2-7
(5) Directional Signal System Circuit	2-8
(6) Instrument Indicators and Horn System Circuits	2-9

2-17. Test Equipment.

a. **Multimeter.** Multimeter TS-352B/U shall be used whenever the procedure specifies a multimeter. The multimeter, a voltohm milliammeter that uses self-contained batteries, is contained in a metal immersion proof carrying case. Refer to the specific electrical troubleshooting section for function and use of the multimeter. TM 11-6625-366-15 contains instructions for the use of Multimeter TS-352B/U.

STARTING SYSTEM CIRCUIT

Description: The starting system consists of the batteries, starting motor assembly, foot starter switch and connecting cables. The starting motor is energized by pressing the foot starter switch. Current flows from the positive terminal of the battery, through the battery to switch cables, through the switch, through the switch-to-starter cable, through the negative terminal of the battery. Faulty connections contribute largely to starter system failures.

Table 2-4 Starting System Circuit Troubleshooting

MALFUNCTION	PROBABLE CAUSE	CORRECTIVE ACTION
1. Starter inoperative	a. Loose connections, cables corroded, broken wires.	a. Perform a visual inspection to insure that cables and wiring harness connections are secure and free of corrosion.
	b. Discharged batteries.	b. Check battery electrolyte level and test with hydrometer. Refer to hydrometer temperature correction chart (para 2-66) for correction factor and battery condition. Charge batteries or replace as required.
	c. Starting motor and/or starter switch inoperative.	c. Check for defective starter switch. Remove starting motor from engine and check for broken or stuck starter drive. Check starting motor for open electrical circuit. Repair or replace defective components as required.
2. Starter turns but will not engage flywheel.	Teeth missing from flywheel ring gear.	Remove starting motor from engine. Inspect flywheel ring gear teeth. If teeth are missing, notify direct support. If ring gear teeth are satisfactory, replace starting motor.
3. Starter turns engine but cranking is slow and sluggish.	a. Discharged batteries	a. Check battery electrolyte level and test with hydrometer. Refer to hydrometer temperature correction chart (para 2-66) for correction factor and battery condition.
	b. Burned starter switch contacts.	b. Replace starter switch.
	c. Starting motor commutator dirty; worn brushes, weak brush spring tension, worn bearings	c. Remove starting motor from engine, repair or replace defective components as required.

CHARGING SYSTEM TROUBLESHOOTING PROCEDURE

Description: The alternator system consists of a 60-ampere, 24-volt, negative ground alternator and internal voltage regulator and rectifier assembly. The circuit is energized by the ignition switch and mechanical rotation of the alternator, which generates alternating current (ac). The alternating current is changed to direct current (dc) by the rectifier bank, and the output voltage is maintained at 28 ± 1 volts by the voltage regulator. This 28 volts is used to charge the vehicle battery and to assist the battery in carrying the electrical load of the vehicle.

Table 2-5. Charging System Circuit Troubleshooting

MALFUNCTION	PROBABLE CAUSE	CORRECTIVE ACTION
1. Discharged battery; slow cranking speed.	a. Low specific gravity	a. Check each battery cell with hydrometer. Refer to chart (para 2-66) for battery charge condition and temperature connection. Charge batteries as required.
	NOTE Batteries must be in good condition and fully charged to make the following checks valid.	
	b. Loose connections.	b. Check that all system connections are clean and secure. Check that wiring or insulation is not broken or frayed. Repair or replace wiring as required
	c. Loose alternator.	c. Check that alternator mounting bolts are secure. Check and adjust alternator drive belt tension (para 2-46j).
	d. Defective batteries.	d. Charge batteries or replace as required. Voltage of fully charged batteries should be 24.0 to 25.5 volts.
2. Gassing battery; excessive water usage.	a. Alternator defective or out of adjustment	a. The alternator is defective and must be replaced.
	b. Unregulated voltage.	b. If the voltage remains constant, the problem is that the voltage setting is too high for the climate and type of service. Adjust voltage.
3. Alternator fails to charge.	a. Belts loose	a. Tighten to specifications.
	b. Open or high resistance in charging or ground return circuit or battery connections.	b. Test and correct. Clean and tighten all connections.
4. Low or unsteady charging rate.	a. Belts loose	a. Tighten to specifications.
	b. Intermittent or high resistance charging of ground return circuit or battery connections.	b. Test and correct. Clean and tighten all connections.
5. Noisy alternator	a. Loose pulley	a. Tighten.
	b. Misaligned belt or pulley.	b. Aline, replace defective components.

IGNITION SYSTEM CIRCUIT

Description: The ignition system consists of a combined distributor and coil assembly (ignitor), shielded spark plug cables, shielded spark plugs, and the

ignition switch. The system is waterproof and radio noise suppressed.

Table 2-6. Ignition System circuit Troubleshooting

MALFUNCTION	PROBABLE CAUSE	CORRECTIVE ACTION
1. Engine cranks, will not start.	a. Fuel system.	a. Check for empty fuel tank, clogged fuel line, water in fuel, defective fuel pump, air in fuel line, fuel boiling in carburetor
	b. Loose connectors and/or broken cables	b. Inspect all wiring harnesses and connectors. Insure that all connectors are secure and that harnesses are not broken
	c. No voltage.	c. Disconnect one spark plug wire from spark plug. Hold 1/8 to 1/4 inch away from cylinder block and have engine cranked. If spark arcs between spark plug wire and cylinder block, ignition system is satisfactory. If no spark arc is observed, reconnect spark plug wire and proceed as follows.
	d. No voltage input.	d. Disconnect primary ignition feed wire from ignitor assembly. Connect 24 volt test light between primary lead end, and ground. Turn ignition switch on. Test lamp should light, indicating a satisfactory circuit. If no light is indicated, check ignition power circuit from ignitor to ignition switch, ignition switch to junction block, and junction block to battery. Repair or replace defective components.
	e. Wiring harness broken and/or shorted.	e. Disconnect leads at ignitor, ignition switch and spark plugs. Check continuity of leads. If any of the leads do not have continuity, replace wiring harness.
	f. Voltage breakdown	f. Remove distributor cover and visually inspect cap, rotor and ignition coil tower for evidence of voltage breakdown. If voltage breakdown is evident, replace defective parts. Leave cover off and proceed as follows.

	g. Ignition coil defective.	g. Check ignition coil primary winding resistance. Set ohmmeter on 10 ohm full scale range. Connect probes to positive and negative terminals of coil. Primary resistance should be 4.26. 4.9 ohms. If ohmmeter indicates 0 ohms or infinite resistance, replace coil. Check secondary resistance from coil primary terminal to tower Resistance must be from 12090 to 13910 ohms. If resistance is not within tolerance, replace ignition coil. Install distributor cover assembly
2. Engine misfires.	a. Spark plugs defective	a. Remove spark plugs and inspect. Clean and regap if necessary. Replace defective spark plugs.
	b. Voltage breakdown	b. Remove ignitor cover and inspect gap, rotor and ignition coil tower for evidence of voltage breakdown. Replace defective parts.
	c. Spark plug cables broken and/or shorted	c. (1) Inspect cables for evidence of breakdown. Check continuity of cables. Replace defective components. (2) Troubleshoot item c, d, and e of 1. above. If engine continues to misfire, substitute an ignitor assembly known to be serviceable Replace original ignitor if substitute corrects malfunction

LIGHTING SYSTEM CIRCUIT

Description: The light circuits are controlled by the light switch on the instrument panel. Each light is connected to the light switch by connectors, wiring harnesses and cables. Each cable is identified by numbered tags near the end of each cable. A circuit breaker protects the system from overload. The lighting circuits are energized from the batteries. Individual or groups of lights are selected by the master light switch, except the stoplamp, which is energized by the stoplamp switch. The directional signal system has an individual actuator or selector on the steering column.

Table 2-7. Lighting System circuit Troubleshooting

MALFUNCTION	PROBABLE CAUSE	CORRECTIVE ACTION
1. Flickering lights (all or most lights).	Battery system, circuits 7, 68, 82, 4 and 5.	Perform a visual inspection of primary power circuits. Check all terminals for tightness and/or corrosion. Manually move wires and cables at terminals to find defective connections. Clean, assemble, and tighten defective connections.
2. Frequent bulb burn out.	Generating system.	Turn ignition switch to ON, and observe battery condition. If in low to high green, indicating overcharge, reduce generating system output voltage.

3. Single lamp, dim, flickering, or out. Remaining lamps of assembly are normal.	Composite lights (front or rear), instrument lights, etc.	Gain access to bulb socket and clean socket mounting for connection to housing or ground wire. Wiggle bulb to determine effectiveness of repair.
4. All lamps of composite assemblies dim, flickering, or out.	Composite lights, front or rear.	Inspect assembly for secureness of mounting. Repair defective ground
5. Service headlight out.	Headlight circuits.	Turn other beam on with headlight selector switch. If lamp lights, replace lamp as it is probably defective. If both beams are out, check circuit 91 for high resistance or open ground. If lamp still does not light, remove lamp from housing and disconnect circuits 17 and 18. Connect a 24-volt test lamp between chassis and circuits 17 and 18. If lamp does not light in either check, troubleshoot circuits 17 and 18 for an open circuit. Assure power at selector switch.
6. Both service headlights out, both beams.	a. Defective light switch.	a. Check for correct position of light switch. Wiggle switch lever in service drive position. If lamps light, replace light switch
	b. Loose connections.	b. Check cable connector at rear of switch for tightness. Wiggle cable to check for intermittent functioning
	c. Defective selector switch.	c. Remove connector from selector switch and connect test lamp between circuit 16 and bare chassis metal. If bulb lights, circuit 16 and light switch are good. Proceed to next test. If bulb does not light, circuit 16 or light switch is defective. Remove connector from light switch and use ohmmeter to check continuity of circuit 16. If 0 ohms, replace light switch. Connect an ohmmeter between selector switch terminals corresponding to circuits 16 and 17. If meter does not indicate 0 ohms, change lead from the 17 terminal to the 18 terminal. If meter does not indicate 0 ohms in one test, replace selector switch. If 0 ohms is indicated, remove a headlight and disconnect circuits 17 and 18. Connect test lamp between bare chassis metal and either circuit. Repeat on other circuit if lamp does not light. Replace both headlights if bulb lights in either test. Troubleshoot circuits 17 and

		18 for an open wire if bulb fails to light in either test.
7. Brake lights out, service and B.O	a. Brake light switch, circuit 75	a. Gain access to brake light bulb and remove. Connect a test lamp between center pin of socket and bare chassis metal. Depress brake. If lamp lights, replace bulbs. If lamp does not light, remove terminal connections (circuit 75) from brake light and short together. If lamp lights, replace brake light switch.
	b. Light switch defective.	b. If lamp does not light, either light switch or circuit 75 is open. Remove connector from light switch and check circuit 75 for continuity Repair cable if open Replace light switch if good (0 ohms).
8. Break lights out, one	Bulb, socket ,associated circuit. Circuit NO. B.O. 23 Service 22	Gain access to brake light bulb and remove. Connect a test lamp between center pin of socket and bare chassis metal. If lamp lights, replace bulb. If new bulb does not light, clean socket-bulb contact area and examine socket-to-assembly mounting for open ground connection or circuit.
9. All lights out.	Prime power circuits, light switch.	Disconnect connector at rear of light switch. Connect a test lamp between pin 15 and bare chassis metal. If bulb lights, replace light switch as internal circuit breaker is stuck open. If not, check circuit 15 to 4 for an open circuit.
10. B. 0. Headlamp out.	B. 0. sealed-beam lamp, circuit 19, light switch.	Remove B. 0. sealed-beam unit from housing. Disconnect circuit 19 and connect test lamp between pin 15 and bare chassis metal. If bulb lights, replace sealed beam unit. If still inoperative, a defective ground exists. Check assembly-to-bracket and bracket-to-chassis mounting.

11. Lights flash on and off.	Shorted circuit.	If in B. O. drive , turn light switch to B.O. marker. If in ser. drive , turn auxiliary switch to park. If lights energized do not flash, troubleshoot associated headlight circuit for a short circuit. (Flashing is due to circuit breaker operation). If lights energized still flash, short circuit is in corresponding rear light circuit. Locate short circuit and repair. The bulb of the shorted circuit will be dim or out.
------------------------------	------------------	--

DIRECTIONAL SIGNAL SYSTEM CIRCUIT

Description: The directional signal light system consists of a signal light switch and harness assembly, distribution box containing a flasher and relays, two front directional lamps and two rear directional lamps. The signal light switch assembly is clamped to the steering column. The flashing of the signal light is caused by a flasher mechanism and three relays located in the distribution box which are connected into the proper signal light circuit when the signal switch is set for a turn. When light switch is in B/O position, the distribution box disconnects the service turn signals and transfers the service stop light to B/O stop light.

Before starting tests, make a thorough visual inspection for loose connections, poor grounds, or frayed or shorted cables. Make all necessary repairs before proceeding

Table 2-8. Directional Signal System Circuit Troubleshooting

MALFUNCTION	PROBABLE CAUSE	CORRECTIVE ACTION
1. Turn signal indicator does not flash. Directional signals good.	a. Lamp, grounding	a. Replace lamp. If lamp does not flash, check switch mounting strap grounding using ohmmeter.
	b. Defective directional switch	b. If satisfactory, replace switch.
2. No rear turn signal, others normal.	Lamps, circuits 22-460 or 22-461.	Place turn signal switch in neutral position and depress brake pedal. If lamp lights, rear lamp and associated circuit is good. Replace defective signal light switch and harness.
3. No front turn signal, others normal	Bulb and circuit 460 or 461.	If lamp does not light, remove bulb, connect test lamp to center pin and ground, and energize turn signal. If lamp lights, replace bulb. If test bulb does not light, replace defective signal switch and harness assembly.

4. No directional signals, but lamps illuminated.	Flasher unit or relays in distribution box.	Replace flasher or distribution box.
5. No directional signals.	No power feed at Term. A Dist. Box.	Test harness and light switch pin A for power feed.

INSTRUMENT INDICATOR, AND HORN SYSTEM CIRCUITS

Description: Primary power for the indicators is obtained via circuit 27, being the on position of the ignition switch. Thus, indicators do not operate with the ignition switch in the off position. Power applied to circuit 27 is run to the oil pressure, fuel level, and temperature and battery condition indicator. Circuits 36, 28 and 33 are the respective indicator to-sender circuits, which are completed to negative battery (circuit 7) via engine block, engine ground strap and frame. The fuel level sender uses circuit 79 (GRD) to obtain a connection to frame. The battery condition indicator is a voltmeter and obtains ground through the instrument panel.

Primary power to the horn is obtained via circuit 25A, which is a direct connection to battery voltage via circuit 5. Connections to negative battery (circuit 7) are obtained via the horn-to-horn button wiring (circuit 25). When the button is depressed, connection is made between circuit 25 and the steering column which is effectively the frame. Thus, horn is operable at all times.

Table 2-9. Instrument Indicator, and Horn System Circuits Troubleshooting

MALFUNCTION	PROBABLE CAUSE	CORRECTIVE ACTION
1. All instruments indicate but flash on and off.	Instruments; circuits 33, 36, 28	Either remove instrument cluster, senders, or if circuit can be safely reached, successively remove lead 27 from indicators. If instruments operate when a specific lead is removed, the associated instrument circuit is shorted, Remove lead from sender end of instrument (circuit 33, 36, or 28). If no associated sender, replace instrument. If instruments indicate after removing lead, replace sender. If they do not, replace indicator after troubleshooting harness lead.

2. Oil pressure remains at initial 0 position.	Defective indicator or sender unit	Stop engine immediately, check oil level. If oil is full, remove instrument cluster and circuit 27 from indicator. Connect a test lamp between bare metal chassis and circuit 27. Turn ignition switch to On. If lamp lights, replace lead and perform a similar test on circuit 36. If lamp does not light, indicator is open Replace indicator If lamp lights perform similar test on circuit 36 at sender. If lamp lights, replace sender.
3. Temperature or fuel level indicator never moves from initial position.	Defective indicator or sender unit	Using the procedure from zero oil pressure and the corresponding circuits shown in Table 2-9, isolate and replace defective components.
4. Battery condition indicator shows low left red but vehicle starts normally.	Defective indicator or open in harness	Check connection of circuit 27 to indicator. Remove lead and connect test lamp to 27 and chassis. If lamp lights, replace indicator. If lamp does not light troubleshoot harness for an open and repair.
5. Battery condition indicator shows, other than high yellow to low green.	Defective battery or defective indicator	Refer to battery system procedures.
6. Horn does not operate, or weak	a. Poor ground.	a. Remove circuit 25 at horn and short terminal to ground with a jumper wire. If horn blows, remove horn button and find the high resistance ground. Remove all corrosion before replacing.
	b. Defective horn	b. If horn does not blow disconnect circuit 25A at horn and connect test lamp between circuit 25A and chassis. If lamp lights, replace horn.

WIRING IDENTIFICATION

Wire marking Circuit no.	Circuit or Function	Wire marking Circuit no.	Circuit or Function
3 (NEG)	ALTERNATOR GROUND CIRCUIT	36	OIL PRESSURE INDICATOR TO SENDING UNIT

4	BATTERY FEED TO NON SWITCHED DEVICES	40	INSTRUMENT LIGHT CIRCUIT
5	ALTERNATOR OUTPUT TO BATTERY	49	RECEPTACLE, AUX. POWER OUTLET, POSITIVE LEAD
6	STARTER SWITCH TO STARTER MOTOR	50	RECEPTACLE, AUX. POWER OUTLET, NEGATIVE LEAD
7	BATTERY GROUND	68	BATTERY INTERCONNECTING CABLE
11	IGNITION SWITCH FEED	73	RADIO TERMINAL BOX TO GROUND (OPTIONAL)
12	IGNITION SWITCH TO IGNITOR	75	STOP SWITCH TO LIGHT SWITCH AND STOP LIGHT
15	MAIN LIGHT SWITCH FEED	76	DESERT, HOT WATER, OR AIR CONDITIONING POWER FEED
16	LIGHT SWITCH FEED TO HEADLIGHT SELECTOR SWITCH	79(GRD)	FUEL INDICATOR SENDING UNIT TO GROUND
17	SELECTOR SWITCH TO HEADLIGHT UPPER BEAM	82	BATTERY FEED TO FOOT STARTER SWITCH
18	SELECTOR SWITCH TO HEADLIGHT LOWER BEAM	85	SPOTLIGHT AND HEATER POWER FEED (M715)
19	LIGHT SWITCH TO BLACKOUT DRIVING LAMP	90	TRAILER RECEPTACLE TO GROUND
20	LIGHT SWITCH TO BLACKOUT MARKER LAMP	91	HEADLIGHT TO GROUND
21	LIGHT SWITCH TO SERVICE TAIL LAMP	460	TURN INDICATOR CIRCUIT, RIGHT FRONT SERVICE
22	LIGHT SWITCH TO SERVICE STOP LAMP	461	TURN INDICATOR CIRCUIT, LEFT FRONT SERVICE
23	LIGHT SWITCH TO BLACKOUT STOP LAMP	22-460	TURN INDICATOR CIRCUIT, RIGHT REAR SERVICE
24	LIGHT SWITCH TO BLACKOUT TAIL LAMP	22-461	TURN INDICATOR CIRCUIT, LEFT REAR SERVICE
25	HORN SWITCH TO HORN	A	LIGHT SWITCH TO DISTRIBUTION BOX
25A	HORN FEED	491	PARKING LIGHTS TO LIGHT SWITCH
27	INSTRUMENT FEED	468	IGNITION SWITCH TO ALTERNATOR
28	FUEL INDICATOR TO SENDING UNIT	(GRD)	DISTRIBUTION BOX GROUND
33	WATER TEMPERATURE INDICATOR TO SENDING UNIT		

Section VII. RADIO INTERFERENCE SUPPRESSION

2-18. General.

Radio interference suppression is the elimination or minimization of electrical disturbances that interfere with radio reception or disclose the vehicle location to sensitive electrical detectors. It is important that all vehicles, whether equipped with radios or not, be properly suppressed to prevent interference with radio reception in neighboring vehicles.

2-19. Interference Suppression Components.

- a. General. The radio interference suppression system does not include any primary suppression components specifically used for this purpose. All components of the cargo truck and ambulance that are capable of emitting radio frequency signals are equipped either with in-line (bypass) capacitors and/or are grounded to the vehicle chassis.
- b. Spark Plugs. The resistor type spark plugs incorporate an extended steel base which shields the ceramic insulator and provides attachment facilities for the shielded spark plug cables.
- c. Spark Plug Cables. Fully shielded spark plug cables are used in conjunction with the shielded resistor spark plugs. The metallic conductor is multiple stranded and double insulated. A spring jacket surrounds the cable insulation and provides rigidity to the cables in higher temperatures. The electromagnetic shielding is a double layer of close weave copper braiding. The shielding allows full flexibility of the spring jacket and still provides continuous shielding. The copper braiding is soldered to formed brass tubing at the ends of the cable. The center conductor is terminated at both ends by a copper alloy spring; is sealed by a rubber sleeve with a shoulder that fits inside the spark plug shield; and expands to a tight fit when the cable connector is tightened.
- d. Distributor and Ignition Coil. The distributor and ignition coil are of unit construction within a continuous casted aluminum housing. The housing has provisions for connecting the spark plug cables as described above. The housing is grounded to the cast iron engine block by the mounting bolt.

2-20. Replacement of Suppression Components.

Refer to the pertinent maintenance paragraphs containing removal and installation instructions for components.

2-21. Testing of Radio Interference Suppression Components.

Since there are no primary suppression components in the system, testing is accomplished in conjunction with electrical troubleshooting procedures.

Section VIII. POWER PLANT REMOVAL AND INSTALLATION

2.22. General.

- a. The power plant assembly consists of the engine, clutch, transmission and all the various engine accessories, less the air cleaner and transmission shift lever. The power plant assembly can be removed as a unit without draining the engine or transmission lubricant. The radiator, transmission clutch and various engine accessories can be replaced individually without removing the power plant, however, to replace the engine assembly, the complete power plant must be removed.
- b. Before attempting to remove or replace the power plant, plan the operation in advance and consider the following items:
 - (1) Block the wheels to prevent the vehicle from rolling.
 - (2) Prepare a strong and level area or bench on which to rest the power plant after removal. Select a location with adequate uncluttered working space.
 - (3) Use hoisting equipment that has sufficient lifting height and capacity to handle the power plant safely.

2-23. Removal.

a. Power Plant.

- (1) Disconnect hood from hood hinges and remove hood from vehicle.
- (2) Drain cooling system and close draincock in radiator; replace plug in block after cooling system is completely drained.
- (3) Disconnect battery cables from battery terminals. Disconnect cable from starter.
- (4) Remove carburetor air cleaner and/or air horn housing.
- V (5) Loosen personnel heater inlet and outlet hose clamps; disconnect hoses from water pump and cylinder head pipe nipple.
- (6) Disconnect choke and accelerator cable from carburetor.
- (7) Remove upper and lower radiator hoses. Remove four radiator support attaching bolts from radiator and shroud. Remove radiator and fan shroud assembly. Remove fan blade assembly from engine.
- (8) Disconnect flexible fuel hose from fuel pump inlet pipe connection adjacent to left frame side rail, below oil filter.
- (9) Disconnect oil pressure and engine temperature sensing switch wires.
- (10) Disconnect primary ignition feed wire at ignitor.
- (11) Disconnect engine ground cables.
- (12) Disconnect cables from carburetor.
- (13) Disconnect exhaust pipe at manifold outlet, also at bracket attaching flywheel housing.
- (14) Disconnect clutch linkage at clutch housing.
- (15) Remove clutch cross shaft. Remove bolts attaching bracket-to-flywheel housing.
- (16) Disconnect power take-off propeller shaft, and propeller shaft from transmission to transfer case. Tie shafts up out of the working area.
- (17) Disconnect transmission vent line from transmission tower cover.
- (18) Disconnect power take-off control from power take-off.
- (19) Loosen transmission shift lever jam nut. Remove shift lever and jam nut. Remove transfer case hand levers and parking brake handle from bracket mounted on the right side of transmission case.
- (20) Attach lifting sling and take up load from engine mounting cushions.
- (21) Remove torque reaction arm insulator (4 fig 2-4) support-to-torque reaction support arm bracket attaching nuts, lock washers and bolts. Remove nuts securing rear insulator assembly (8 fig 2-4) to rear crossmember.
- (22) Remove front engine mount attaching nuts,
- (23) Tilt power plant as required and carefully use hoist to remove it from the vehicle.

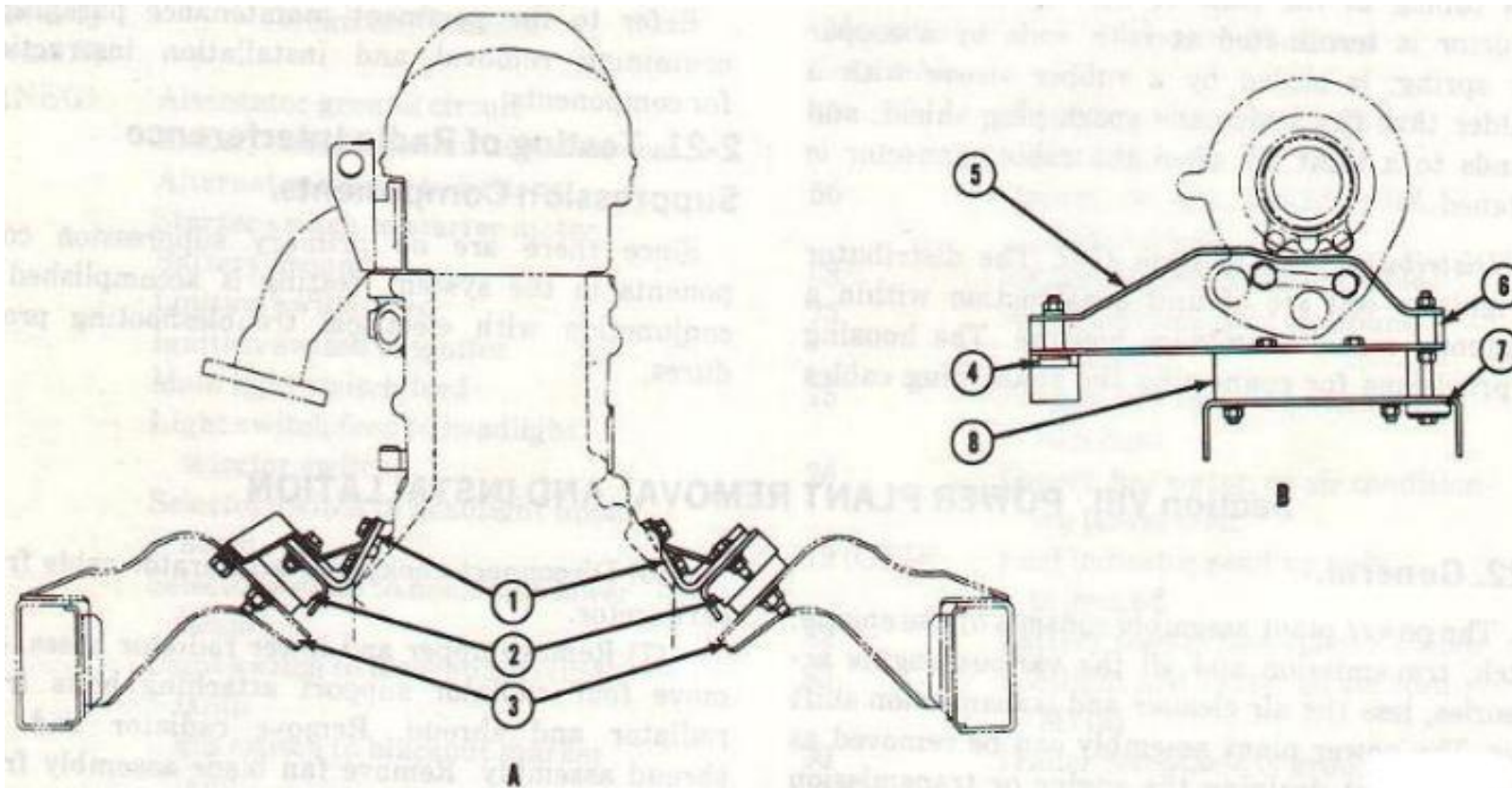

Figure 2-4. Engine supports.

A Engine front view

B Transmission rear view

1 Engine adapter bracket	4 Torque reaction arm insulator
2 Front rubber insulators	5 Torque reaction support arm
3 Frame side rail brackets	6 Spacer
	7 Rebound pad
	8 Rear insulator assembly

b. Engine Rear Insulator Assembly. The engine rear insulator assembly (8 fig 2-4) normally is removed during power plant removal, however, it can also be removed separately from the power plant using the following procedure.

(1) Place a jack or other suitable lifting device under the engine assembly.

(2) Remove nuts, bolts, and washers attaching rear insulator assembly (8 fig 2-4) to torque reaction support arm (5 fig 2-4). Remove nuts securing rear insulator assembly (8 fig 2-4) to rear crossmember.

(3) Jack up engine about 1-inch and remove rear insulator assembly.

c. Engine Front Rubber Insulators. The engine front rubber insulators (2 fig 2-4) normally are removed during power plant removal, however, they can also be removed separately from the power plant using the following procedure.

- (1) Remove nuts and washers from engine front rubber insulator (2 fig 2-4) attaching bolts.
- (2) Remove attaching bolt nuts, washers and bolts from frame side rail brackets (3 fig 2-4).
lock washers and bolts. Raise engine slightly and remove front rubber insulators (2 fig 2-4) and rear insulator assembly (8 fig 2-4).
- (3) Jack up engine about 1-inch and remove front rubber insulators (2 fig 2-4).

2-24. Installation.

a. Power Plant Assembly.

- (1) Attach the engine lifting sling and carefully position the power plant in the vehicle.
- (2) Check and tighten the engine rear support crossmember-to-frame side rail attaching bolts.
- (3) Position the front and rear engine rubber insulators (2, 8, fig 2-4) attaching bolts and tighten. Install front bolts, washers and nuts. Tighten nuts.
- (4) Remove lifting sling from engine lifting eyes.
- (5) Install radiator and fan shroud on radiator body support and secure with four bolts and washers.
- (6) Install propeller shaft from transfer case to transmission.
- (7) Install power take-off propeller shaft and connect power take-off controls.
- (8) Connect transmission vent line to transmission tower cover.
- (9) Connect clutch linkage at clutch housing and engine bracket.
- (10) Install clutch cross shaft.
- (11) Connect exhaust pipe to exhaust manifold; connect exhaust pipe bracket to flywheel housing.
- (12) Install transmission shift lever jam nut and shift lever. Tighten jam nut securely.
- (13) Connect engine ground cables.
- (14) Connect alternator cables.
- (15) Connect primary ignition feed wire to ignitor.
- (16) Connect oil pressure and engine temperature sensing switch wires.
- (17) Connect flexible fuel hose to fuel pump inlet pipe adjacent to left frame side rail below oil filter.
- (18) Connect choke and accelerator cable to carburetor,
- (19) Install air cleaner assembly on carburetor and tighten clamp.
- (20) Connect hose and carburetor air inlet extension to carburetor air horn and tighten clamp.
- (21) If personnel heater is used, connect inlet and outlet hoses to water pump and cylinder head nipple fittings. Tighten hose clamp screws.
- (22) Connect battery cables to starting motor and battery terminals.
- (23) Inspect installation and check linkages for proper operation.
- (24) Check engine oil, transmission lubricant and engine coolant levels. Refill with the proper seasonal lubricant and coolant solution as required.
- (25) Start engine and check all instruments for proper operation. Observe all fluid connections and under vehicle for indications of leakage.
- (26) Install hood assembly.

b. Engine Rear Rubber Insulator (with Power Plant Installed).

- (1) Position rear rubber insulator (8 fig 2-4) on engine rear support crossmember.
- (2) Start attaching bolts into rear rubber insulator assembly. Lower engine on insulator (8 fig 2-4) and tighten attaching bolts and nuts.

c. Engine Front Rubber Insulator (with Power Plant Installed).

- (1) Position engine front rubber insulators (2 fig 2-4) on crossmember,
- (2) Install bolt, lock washer and nut. Lower engine on front rubber insulators (2 fig 2-4). Tighten nuts.

Section IX. MAINTENANCE OF ENGINE

2-25. General.

- a. Description. The engine assembly (fig 2-5) is a six cylinder, in-line gasoline type, four cycle, liquid cooled, with overhead cam and valves. Positive crankcase ventilation is provided through a closed system. All ignition system components are waterproof. Pressure lubrication, with a full flow oil filter, is provided by a gear type oil pump. A built-in bypass at the top of the filter provides oil to the system in the event the filter element becomes clogged.
- b. Locational Terms. The fan end of the engine is referred to as the front and the flywheel end as the rear, The terms left and right respectively, refer to the engine as it is viewed from the rear.

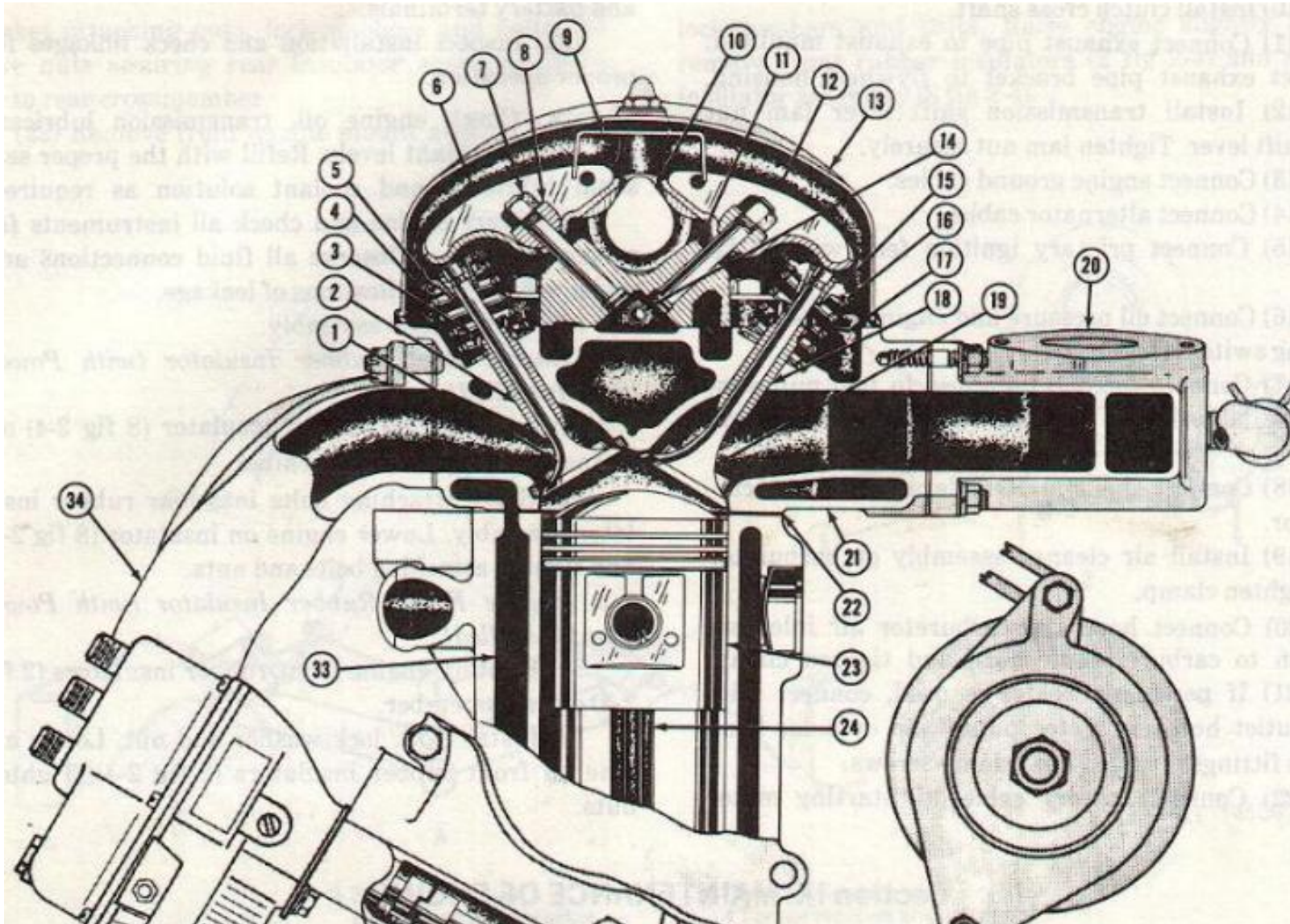

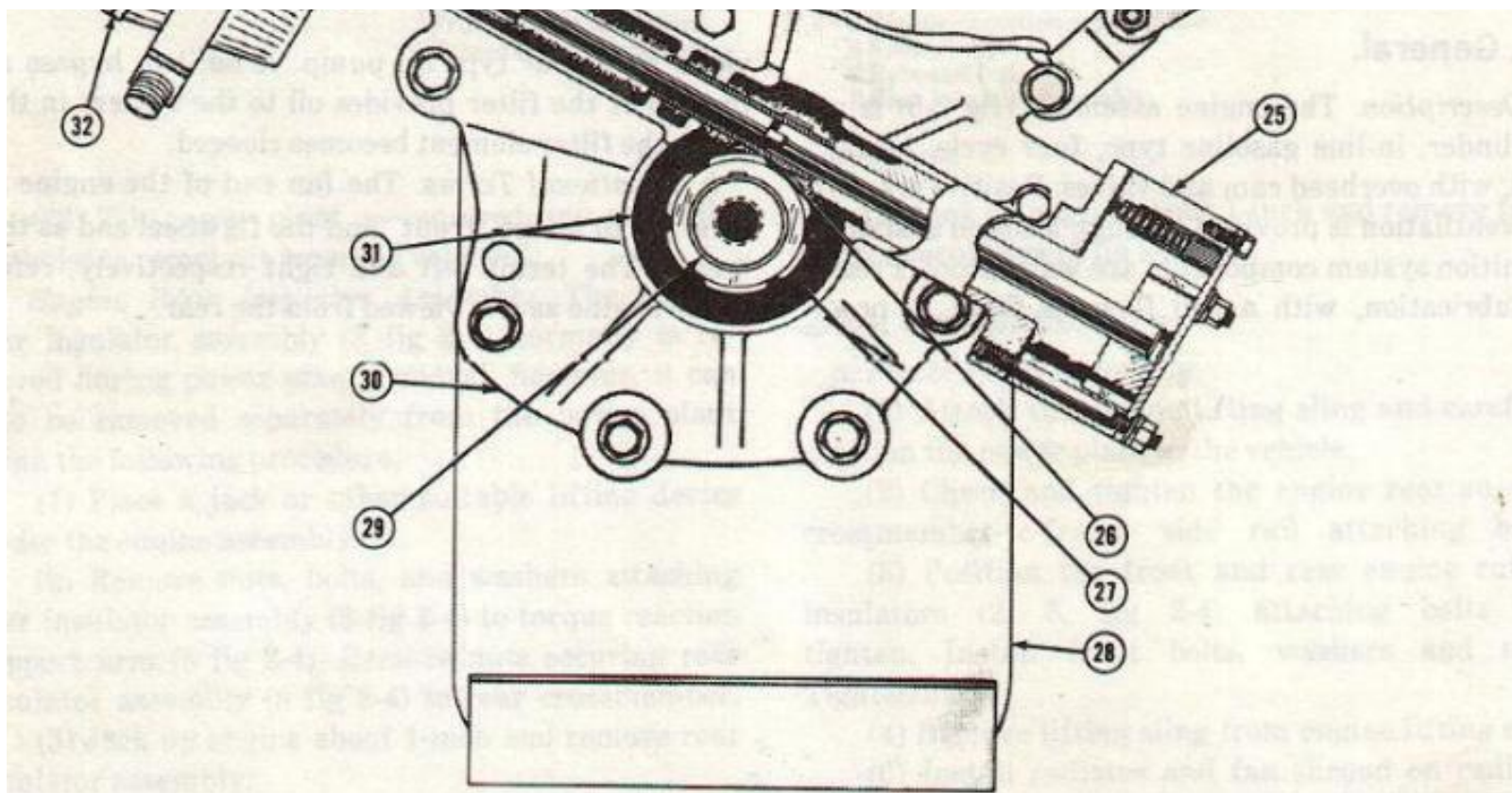

Figure 2-5. Front Sectional View

1 Exhaust valve	10 Camshaft	19 Intake valve	28 Oil pan
2 Exhaust valve guide	11 Cam bearing support deck	20 Intake manifold	29 Crankshaft
3 Valve guide seal	12 Intake rocker arm	21 Cylinder head	30 Timing chain cover
4 Valve spring	13 Rocker arm cover	22 Cylinder head gasket	31 Timing chain cover oil seal
5 Exhaust valve rotator	14 Lubrication pipe	23 Piston	32 Ignitor
6 Exhaust rocker arm	15 Intake valve spring retainer	24 Connecting rod	33 Cylinder block
7 Rocker arm stud	16 Valve spring	25 Oil pump	34 Exhaust manifold
8 Rocker arm ball	17 Valve guide seal	26 Oil pump driven gear	
9 Rocker arm guide	18 Intake valve guide	27 Oil pump drive gear	

2-26. MAINTENANCE AND ADJUSTMENTS

a. General. The maintenance operations authorized to organizational maintenance personnel by the Maintenance Allocation Chart (Appendix B) are to be performed with the engine installed in the vehicle. Refer to the Manual Index to locate the appropriate paragraphs for maintenance on engine components or accessories.

b. Draining Crankcase.

- (1) Place a suitable container under the engine oil pan drain plug.
- (2) Remove drain plug located at the lower rear edge of oil pan assembly. Allow oil to drain completely.
- (3) Install oil pan drain plug and tighten to 25-30 lbs-ft.

c. Filling Crankcase.

- (1) Remove oil filler cap located on rocker arm cover assembly.
- (2) Install 5 quarts (6 quarts if oil filter element was changed) of proper seasonal grade engine oil. (Refer to Lubrication Order, LO 9-2320-244-12).
- (3) Install oil filler cap and tighten securely.
- (4) Remove container from under vehicle.
- (5) Remove oil dip stick and inspect.

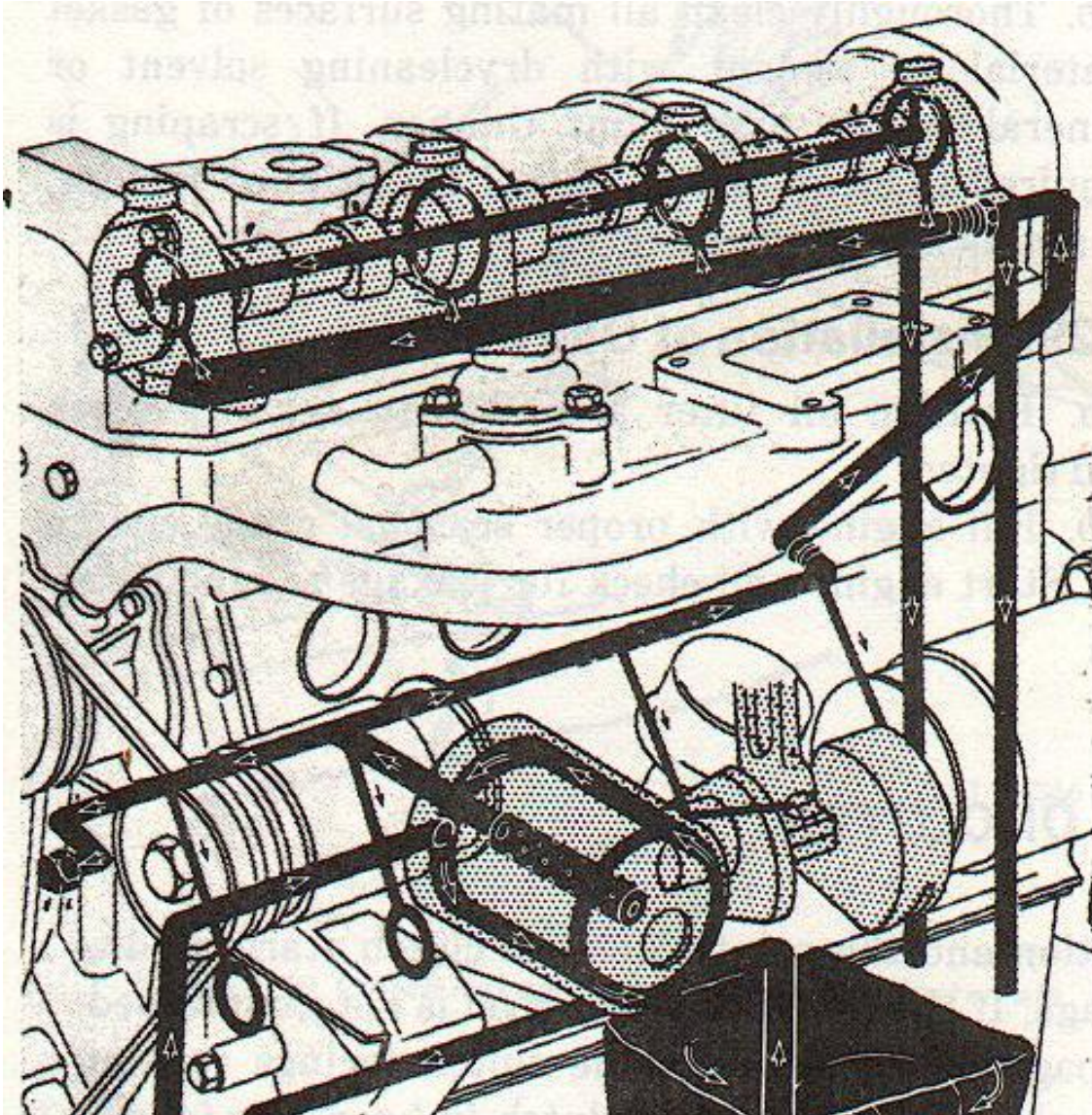



FIGURE 2-6 Engine Lubrication System

d. Cylinder Compression Test.

- (1) Start the engine and run for a minimum of 1/2 hour at a fast idle. Turn ignition switch off.
- (2) Remove spark plug assemblies (para 2-52d).
- (3) Block the carburetor throttle and choke valves to wide open position. Insure that choke control cable is pushed in tight against the instrument panel.
- (4) Begin with number 1 cylinder and insert compression pressure gage into each spark plug hole in turn and crank engine with the starter (fig 2-7).
- (5) Repeat test on each cylinder, cranking the engine until maximum compression pressure is obtained. Record the highest compression pressure indication on DA Form 2404.
- (6) Compare the compression pressures of the cylinders. Normal compression pressure is 135 to 145 psi at cranking speed. Pressures should be uniform within 15 psi. A low compression pressure on two adjacent cylinders indicates the possibility of a leak from one cylinder to the other at the cylinder head gasket. The leakage may be caused by improperly tightened cylinder head bolts, or a faulty cylinder head gasket. If any leakage is observed, report the condition to the direct support maintenance activity for maintenance disposition.

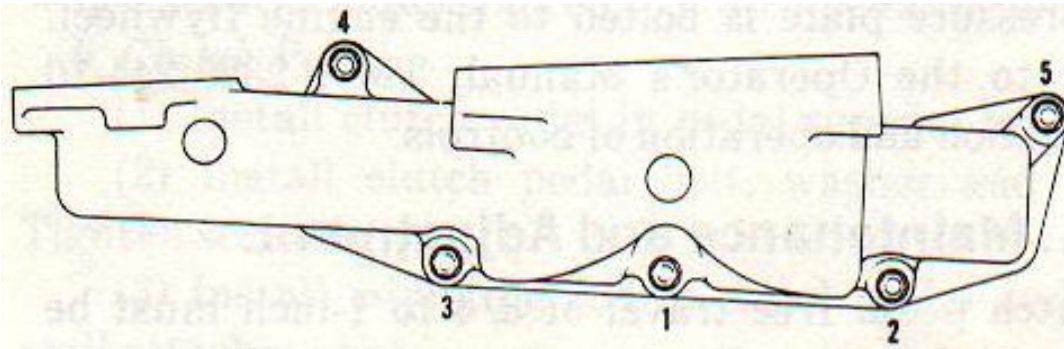

FIGURE 2-8. Intake Manifold Stud Nut Tightening Sequence

e. Manifold Vacuum Test.

- (1) Tighten intake manifold nuts to proper torque (15-20 lbs-ft) following sequence shown in figure 2-8. Remove the pipe plug located at the top rear of intake manifold. Insert adapter into manifold and connect hose to vacuum gage. Insure that all connections are tight, even a slight leak will result in a false vacuum indication.
- (2) Start engine and run at idle speed (650 rpm) until minimum operating temperature (180°F) is obtained. Check carburetor adjustments (para 2-36a).
- (3) With the engine idling at 600 rpm, the vacuum gage should indicate a steady vacuum of 18 to 20 inches of mercury. As a further check, open and close

the throttle quickly. If the engine is in good condition, vacuum should decrease to 3 inches of mercury at wide open throttle and quickly increase to 24 inches of mercury at closed throttle. If this action is not obtained, worn piston rings, or an abnormal restriction in the carburetor, air cleaner or exhaust system is indicated.

NOTE

The above vacuum indications are to sea level operation. At higher elevations, the vacuum indications are lowered approximately 1 inch of mercury for each 1,000 feet increase in altitude.

(4) After performing the manifold vacuum test, remove adapter from intake manifold and reinstall the pipe plug. Tighten plug securely.

f. Tune-up Procedures.

(1) Cylinder compression test. Refer to (d) above.

(2) Manifold vacuum test. Refer to (e) above.

(3) Spark plug service.

(a) Inspect each spark plug individually for badly worn electrodes, glazed, broken or blistered porcelains. Replace spark plugs where necessary.

(b) Clean serviceable spark plugs thoroughly, using an abrasive type cleaner such as sand blast. File the center electrode flat.

(c) Adjust spark plug gaps to .030 inch using a feeler gage.

NOTE

Never bend the center electrode to adjust gap. Always adjust gap by bending ground or side electrode.

(d) Inspect and clean spark plug threads before reinstalling spark plugs.

(4) Remove ignitor cover. Clean cover and inspect for cracks, carbon tracking and burned or corroded terminals. Replace cover when required.

(5) Replace oil soaked or damaged spark plug cables. Install all cables to the proper spark plug. Proper positioning of spark plug cables in supports is important to prevent cross firing.

(6) Tighten all ignition system connections.

(7) Replace or repair any wires that are frayed, loose or damaged.

(8) Check ignition timing and adjust as necessary (2-51c).

(9) Adjust carburetor mixture screw following procedure outlined in paragraph 2-36a. Set engine idle speed to 600 rpm.

2-27. Removal of Oil Filter.

a. Remove drain plug from oil pan and drain engine oil (para 2-26b).

b. Remove oil filter assembly. Discard filter and gasket.

2-28. Cleaning and Inspection.

a. Refer to TM 9-208-1 for general cleaning and inspection procedures.

b. Thoroughly clean all mating surfaces of gasket material or sealant with drycleaning solvent or mineral spirits base paint thinner. If scraping is required to clean off old gasket material or sealant, do not nick or gouge surfaces.

2-29. Installation of Oil Filter.

a. Position oil filter assembly to cylinder block and tighten.

b. Fill engine with proper seasonal grade engine oil. Start engine and check for leakage around filter.

Section X. MAINTENANCE OF CLUTCH

2-30. General.

The clutch assembly consists of the clutch disk, pressure plate, clutch release bearing and release fork which is actuated by the clutch pedal. The clutch disk is splined to the transmission shaft and the pressure plate is bolted to the engine flywheel. Refer to the Operator's Manual, TM 9-2320-244-10 for location and operation of controls.

2-31. Maintenance and Adjustment.

Clutch pedal free travel of $\frac{3}{4}$ to 1-inch must be maintained during all types of operation. Free travel is the distance between the clutch pedal released position and the point when the clutch starts to disengage. If the specified free travel is not maintained, slippage occurs between the clutch facings causing excessive wear. To adjust clutch linkage, the following adjustment sequence should be followed:

a. Disconnect the adjusting rod from the clutch pedal. Turn the adjusting nut in or out of the clutch bracket to position the clutch pedal. Hold a ruler perpendicular to the toe-riser panel and adjust pedal stop until top of clutch pedal pad is $7\frac{1}{2}$ -inch minimum from toe-riser panel to $1\frac{1}{2}$ -inch above the brake pedal, (fig 2-9).

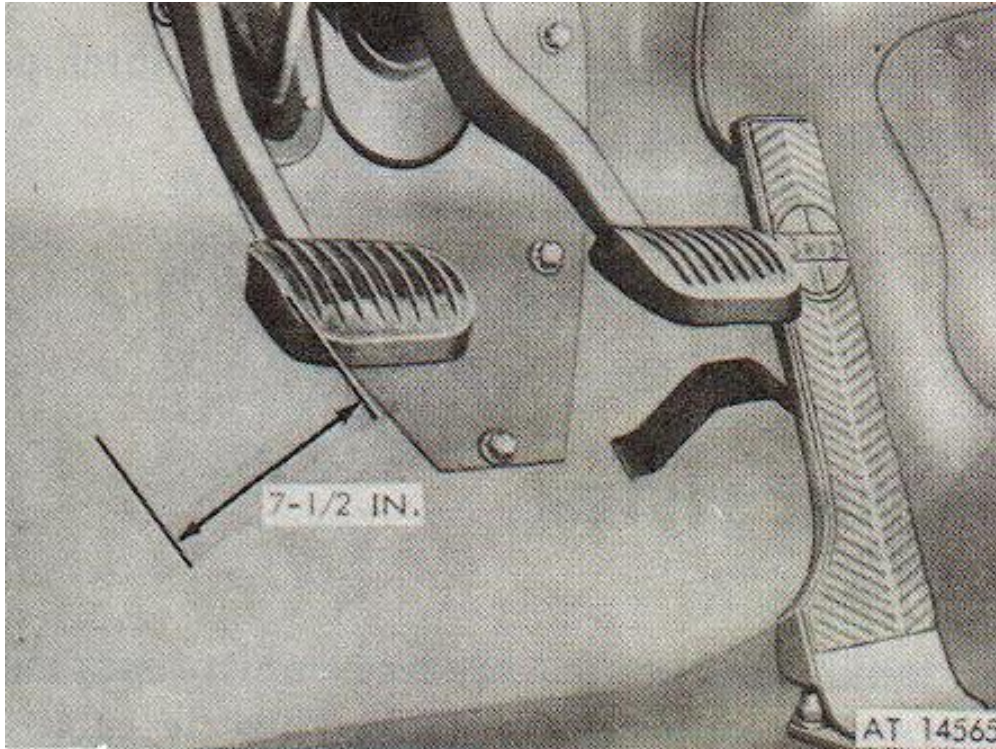

FIGURE 2-9 Clutch Pedal To Toe Panel Measurement

b. With the clutch pedal positioned up against the adjusting bolt, adjust the length of the rod so that it can be connected to the pedal with a 49 angle maintained between the frame and cross shaft lever at the point indicated in figure 2-10.

c. To adjust clutch free pedal, adjust the cross shaft-to-throwout lever link so that the clutch pedal can be pressed $\frac{3}{4}$ -inch to 1-inch before clutch disengagement starts.

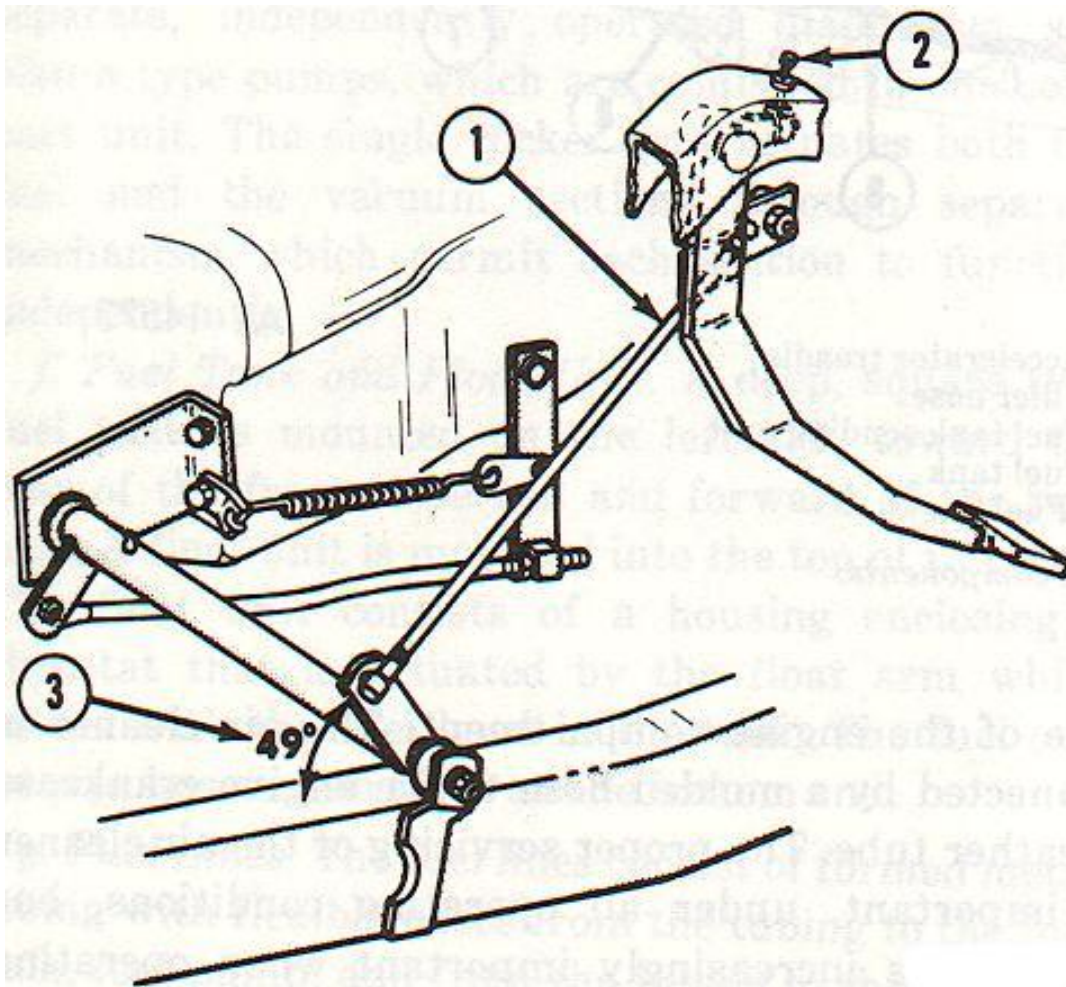

Figure 2-10. Clutch linkage and clutch pedal adjustments.

- 1 Adjusting rod
- 2 Adjusting bolt
- 3 49° angle

2-32. Removal.

a. Clutch Pedal

- (1) Disconnect clutch pedal return spring.
- (2) Remove nut and lock washer which secures adjusting rod to clutch pedal and disconnect adjusting rod from pedal.
- (3) Remove nut, plain washer and bolt which secure clutch pedal to clutch pedal bracket.
- (4) Remove clutch pedal out of pedal support bracket.

b. Clutch Pedal Support Bracket.

- (1) Disconnect clutch pedal return spring.
- (2) Remove nut and lock washer securing adjusting rod to clutch pedal; disconnect rod from pedal.
- (3) Remove bolts and nuts securing support bracket to firewall.
- (4) Remove bolts securing support bracket to instrument panel.
- (5) Remove clutch pedal and support bracket as an assembly.

c. Clutch Linkage.

- (1) Remove nut and lock washer which secures adjusting rod to clutch lever and shaft assembly.
- (2) Remove adjusting rod.
- (3) Remove nut and lock washer which secures clutch fork push rod from lever and shaft assembly.
- (4) Remove clutch fork push rod.
- (5) Remove nut and washers which secure lever and shaft assembly to frame bracket.
- (6) Remove clutch shaft to frame bracket ball stud, spring, seal, seat, lever and shaft assembly.
- (7) Remove bolts which secure clutch shaft to engine bracket.
- (8) Remove clutch shaft to engine ball stud assembly.

2-33. Cleaning and Inspection.

- a. Refer to paragraph 2-12 for general cleaning procedures.
- b. Clean and lightly oil threads of all attaching bolts and nuts.
- c. Inspect threads of nuts and bolts for indication of cross threading and stripping. Rethread or replace as required.

2-34. Installation.

a. Clutch Linkage.

- (1) Install clutch shaft to engine ball stud and bracket assembly. Tighten attaching bolts securely.
- (2) Install clutch lever and shaft assembly, frame bracket ball stud, spring, seat, seal, washers and nut. Tighten securely.
- (3) Install clutch fork push rod and install push rod attaching nut to lever and shaft assembly.
- (4) Install clutch adjusting rod and attach nut which secures adjusting rod to clutch pedal assembly.

b. Clutch Pedal.

- (1) Install clutch pedal in pedal support bracket.
- (2) Install clutch pedal bolt, washer and nut. Tighten securely.
- (3) Install adjusting rod in clutch pedal and install attaching nut.
- (4) Connect clutch pedal return spring.
- (5) Adjust clutch pedal free travel as outlined in paragraph 2-31.

c. Clutch Pedal Support Bracket.

- (1) Position clutch pedal support bracket to firewall and install bolts and nuts. Tighten securely.
- (2) Install support bracket-to-instrument panel bolts and tighten.
- (3) Connect clutch adjusting rod to clutch pedal and secure with nut and lock washer.
- (4) Connect clutch pedal return spring.

Section XI. MAINTENANCE OF FUEL SYSTEM

2-35. General.

The components comprising the fuel system (fig 2-11) include the carburetor, fuel pump, fuel filter, fuel tank, fuel tank sending unit, fuel lines, accelerator treadle, choke cable, throttle cable and filler hose.

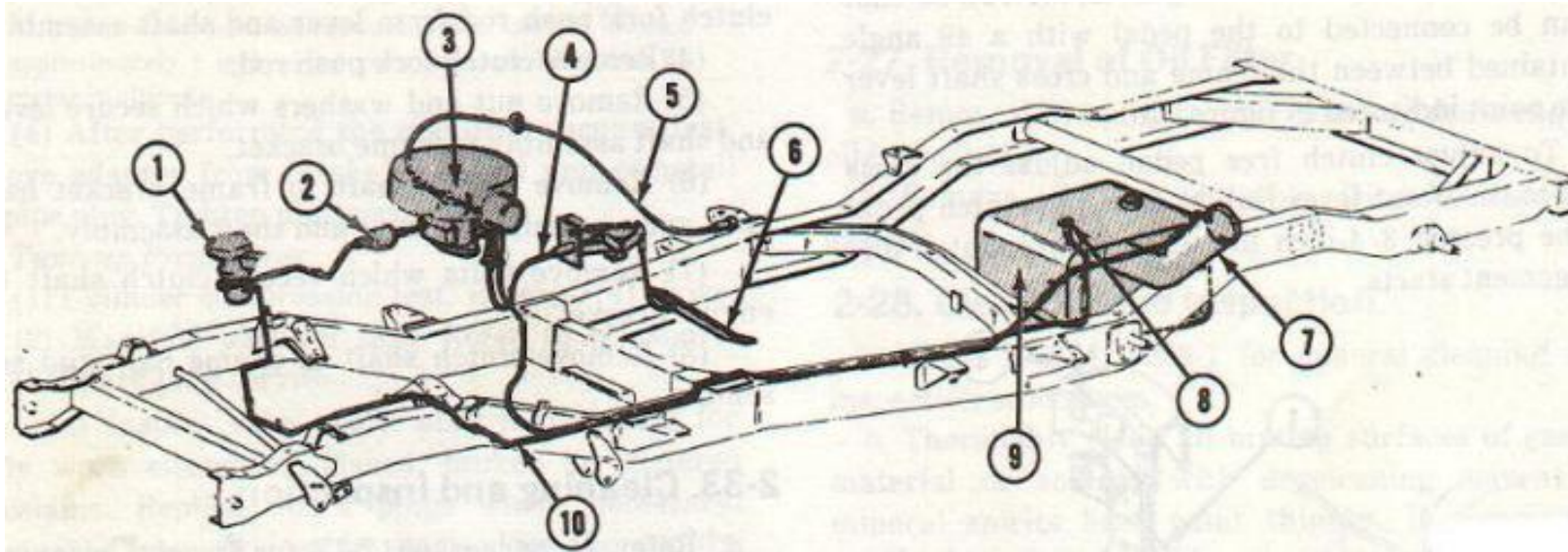

FIGURE 2-11. Fuel System Components

- 1 Fuel pump
- 2 Fuel filter
- 3 Carburetor
- 4 Accelerator cable
- 5 Choke cable
- 6 Accelerator treadle
- 7 Filler hose
- 8 Fuel tank sending unit
- 9 Fuel tank
- 10 Fuel line

- a. Carburetor. The carburetor is concentric downdraft type equipped with a manual choke. The carburetor controls and vaporizes the fuel through six separate operating systems: fuel inlet system, idle system, accelerating pump system, main metering system, power enrichment system and the choke system. The carburetor is mechanically controlled by the accelerator pedal and hand choke.
- b. Governor. The governor, installed on vehicles beginning with serial numbers M715-28680, M725-13577, M726-10001 is a velocity type that is preset and sealed by the manufacturer. The engine speed is controlled by the velocity of gasoline and air mixture passing through the governor from the carburetor.
- c. Air Cleaner. The air cleaner incorporates a paper element air filter and is mounted on the left side of the engine compartment. The air cleaner is connected by a molded hose to the engine crankcase breather tube. The proper servicing of the air cleaner is important, under all operating conditions, but it becomes increasingly important when operating under extreme conditions of dirt and dust.
- d. Positive Crankcase Ventilation. Positive crankcase ventilation of the engine is provided by tubing, rubber hoses, fittings and a regulating valve. The ventilation system uses vacuum from the intake manifold to draw oil vapors and exhaust blow-by through the valve into the combustion chamber where they

are burned. Clean air from the carburetor inlet is routed through the crankcase and in this way the manifold vacuum maintains a continuous circulation of air through the crankcase to reduce air pollution. Refer to figure 2-12.

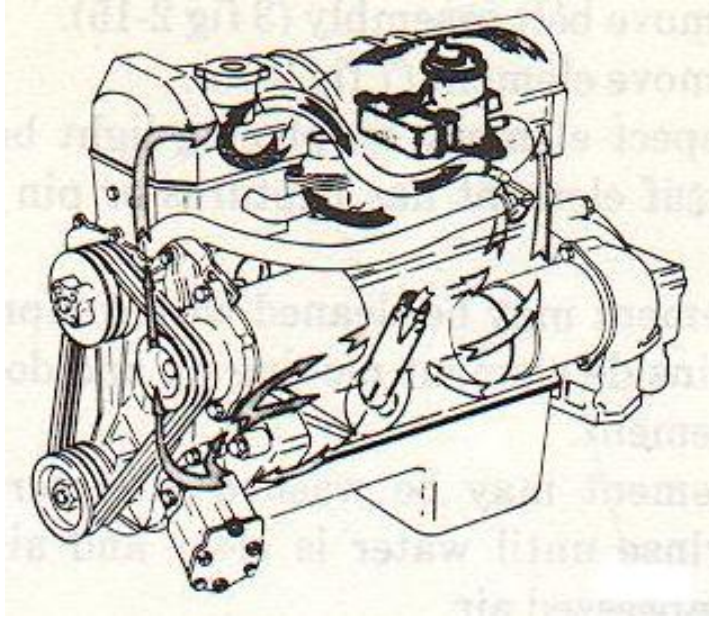

Figure 2-12. Crankcase ventilating system (schematic)

- e. **Fuel and Vacuum Pump.** The combination fuel and vacuum pump is mounted on the upper right side of the engine timing chain cover. The pump rocker arm is actuated by an eccentric mounted on the front side of the camshaft sprocket. The fuel section is located below the vacuum section of the pump assembly. It has a built-in air dome with a diaphragm to damper out pulsations in the fuel stream. The fuel and vacuum sections form two separate, independently operated diaphragm and piston type pumps, which are combined in one compact unit. The single rocker arm actuates both the fuel and the vacuum sections through separate mechanism which permit each section to function independently.
- f. **Fuel Tank and Float Unit.** A deep, square type fuel tank is mounted on the left side toward the rear of the frame side rail and forward of the rear axle. A float unit is mounted into the top of the tank. The float unit consists of a housing enclosing a rheostat that is actuated by the float arm which moves with the fuel level in the tank. The fuel outlet pipe has a mesh filter on the bottom end.
- g. **Fuel Lines.** The fuel lines consist of formed metal tubing with flexible hoses from the tubing to the fuel tank, fuel pump, and from the tubing to the carburetor.

2-36. Maintenance and Adjustment

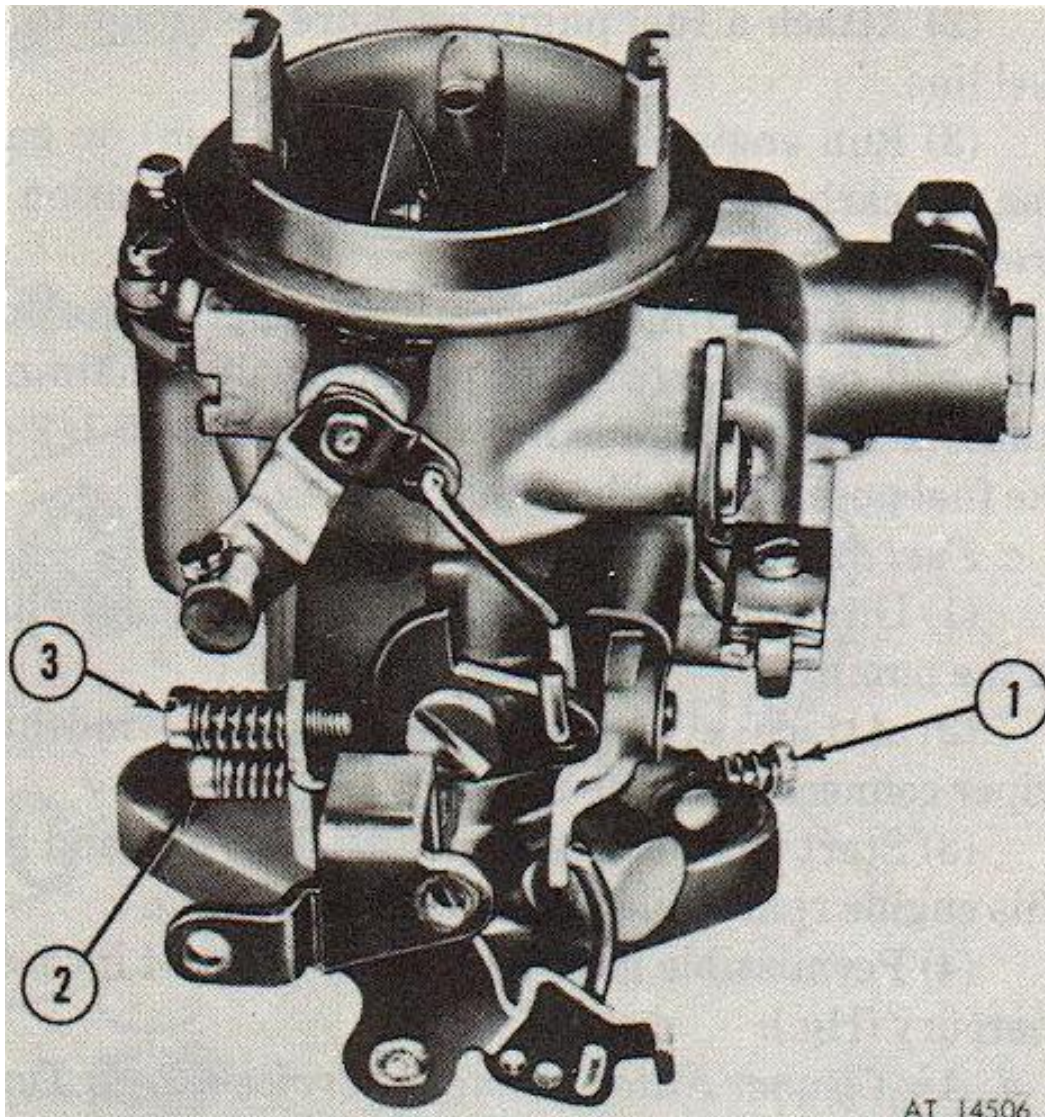

Figure 2-13. Carburetor adjustments.

- 1 Idle mixture screw
- 2 Idle speed screw
- 3 Fast idle screw

a. Carburetor Mixture and Idle Speed Adjustment.

(1) To make the idle speed adjustment, the engine must be thoroughly warmed up. It is recommended that a tachometer and vacuum gage be used in this adjustment. Before making the idle speed adjustment, observe the following precaution; because the alternator can charge at idle speeds and impose a load on the engine, the headlights should be turned on. This will assure setting the idle to compensate for the alternator load. To make the idle speed adjustment, proceed as follows:

(a) Turn the idle speed screw (2 fig 2-13) in or out to obtain 600 to 650 rpm. (Be sure that the choke plate is fully open and that the fast idle adjusting screw

is not contacting the cam).

(b) Adjust the idle mixture screw (1 fig 2-13) to obtain the highest rpm. While making the adjustment, carefully watch the tachometer and vacuum gage and notice that the speed can be decreased by turning the screw in either direction from the setting that gave the highest rpm and vacuum gage reading.

(c) From the highest idle speed setting, turn the mixture screw clockwise (leaner) until the speed starts to drop. Turn the screw in the opposite direction (counter-clockwise) just far enough to recover the speed that was lost. Since the correct speed was originally set using the idle speed screw, the speed obtained after finding the leanest smooth idle setting will probably be too fast.

(d) Readjust the idle speed screw to obtain correct idle speed. Repeat steps (b) and (c) above.

(e) To make the fast idle speed adjustment, adjust the choke wire to provide maximum operation of the choke lever when the choke knob is pushed in or pulled out. With the engine shut off and the choke control pushed all the way in (choke plate open) adjust fast idle screw (3 fig 2-13) to obtain .030 between the end of the screw and the cam.

b. Fuel Pump Pressure Test.

(1) Disconnect fuel inlet line from carburetor inlet pipe.

(2) Attach a fuel pump pressure test gage to the fuel line.

(3) Run engine at idle speed (600 rpm) on gasoline in carburetor bowl and observe indication on pressure gage.

(4) If fuel pump is operating properly, the pressure will be 3-1/2 to 5-1/2 psi and will remain constant. If the pressure is not within 3-1/2 to 5-1/2 psi, the fuel pump should be replaced.

c. Fuel Pump Vacuum Booster Test.

(1) Disconnect both inlet and outlet vacuum lines at the pump.

(2) Attach a vacuum gauge to the windshield wiper connection at the pump.

(3) Start engine accelerate to 2,000 rpm, and hold this engine rpm while taking a gage reading.

(4) Permissible gage reading is 10 to 14 inches of mercury (Hg.).

d. Air Cleaner Filter Element Service (Early Type).

(1) Release retaining clips.

(2) Remove cover (4 fig 2-14).

(3) Remove filter element (3) and gasket (2) (fig 2-14).

(4) Inspect top and bottom of element seals for cracking or deformation. These surfaces must be smooth and uniform.

(5) Inspect element for punctures.

(6) Clean element by tapping lightly on a flat surface.

(7) Element may be cleaned with low pressure compressed air. Direct air from inside the element to the outside.

(8) Internal portions of air cleaner should be cleaned of dust and dirt. If washed with solvents, surfaces must be thoroughly dried before element is installed.

(9) Clean precleaner with compressed air.

e. Air Cleaner Filter Element Service (Late Type).

(1) Pull lanyard pin and lower air cleaner assembly.

(2) Loosen cover assembly wing nut and remove cover (2 fig 2-15) and gasket (4 fig 2-15).

(3) Remove bolt assembly (3 fig 2-15).

(4) Remove element (7 fig 2-15).

(5) Inspect element by placing light bulb inside of element, if element has ruptures or pin holes, replace.

(6) Element may be cleaned with compressed air. Direct air inside element moving up and down, while rotating element.

(7) Element may be washed in water. Soak 15 minutes, rinse until water is clear and air dry. Do not use compressed air.

(8) Loosen clamp (5 fig 2-15) and clean precleaner (6 fig 2-15).

CAUTION

Do not tap or hit air cleaner element.

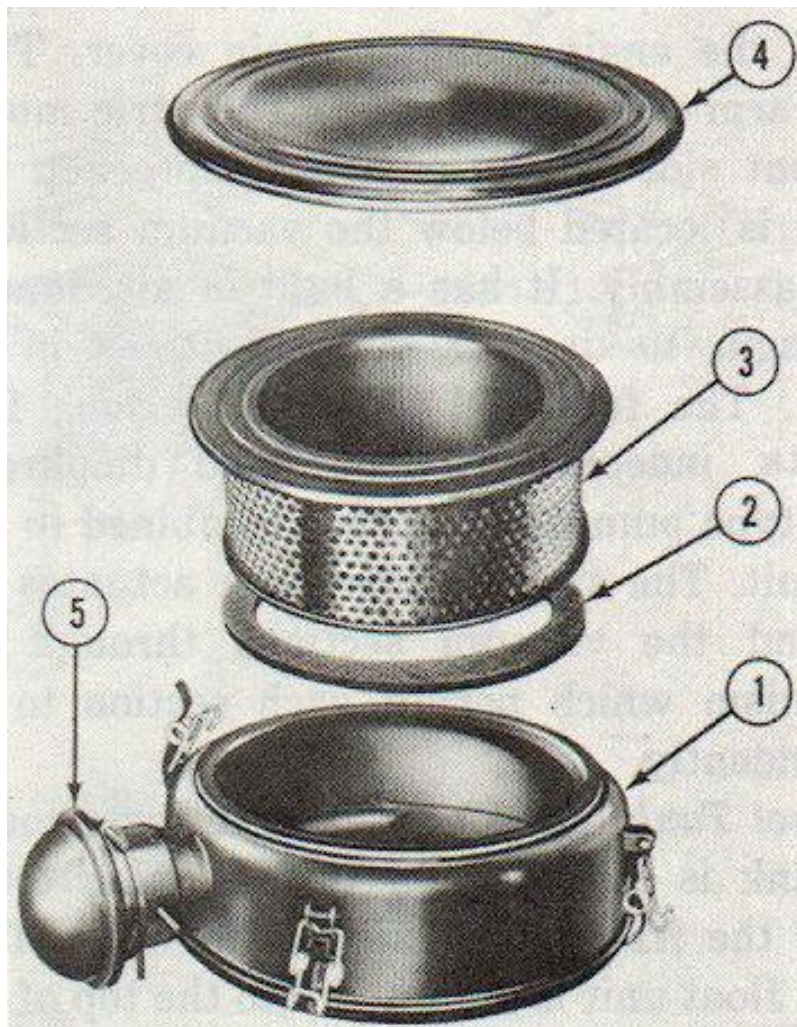

Figure 2-14. Air Cleaner (Early Type)

- 1 Air cleaner
- 2 Gasket
- 3 Element
- 4 Cover
- 5 Precleaner
- 6 Retaining clip

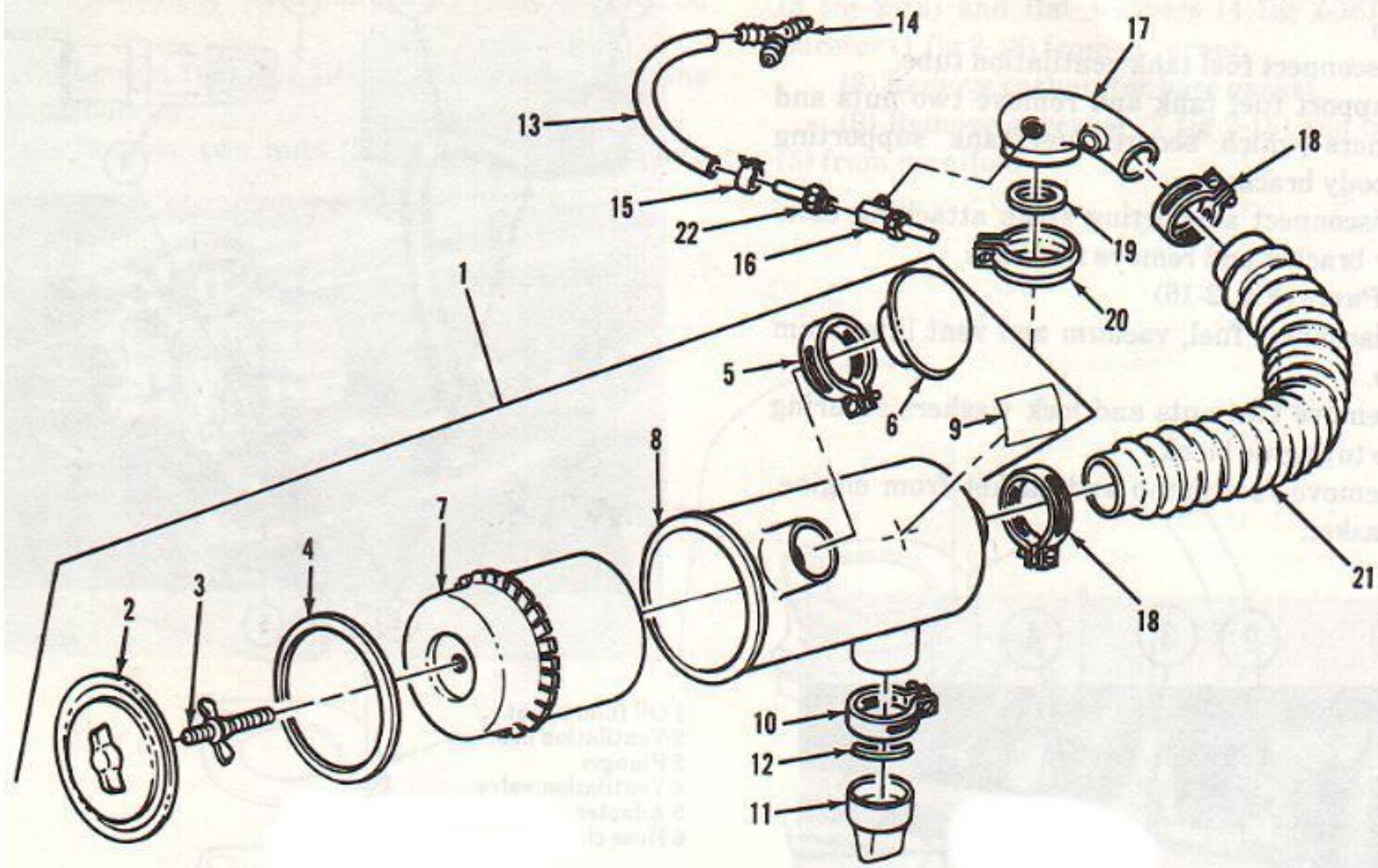

Figure 2-15. Air cleaner (late type).

1 Air cleaner assembly	7 Element	13 Vacuum hose	19 Gasket
2 Cover	8 Body assembly	14 Tee	20 Clamp
3 Bolt assembly	9 Decal	15 Clamp	21 Hose
4 Gasket	10 Clamp	16 Tee	22 Vent line
5 Clamp	11 Valve	17 Horn	
6 Precleaner cap assembly	12 Spring	18 Clamp	

f. Positive Crankcase Ventilation. The crankcase ventilation system (fig. 2-12) should be periodically inspected for loose, deteriorated or plugged hoses. Inspect all hose connections. Oil leakage at the rocker arm cover may be an indication that the ventilation control valve is restricted. Remove regulator valve

and wash in cleaning solvent; dry with compressed air, Connect a tachometer and vacuum gage; start engine and adjust idle speed and carburetor mixture (a) above. Remove the ventilation valve hose from the rocker arm cover, Block the hose opening and observe engine rpm change. A decrease of less than 50 rpm indicates a plugged ventilation valve.

g. Choke Control Cable Adjustment.

- (1) Remove air cleaner and/or air horn housing.
- (2) Loosen choke cable retaining screw on right hand side of carburetor.
- (3) Push control knob completely in against instrument panel.
- (4) Insure that choke blade is completely open; tighten cable retaining screw.
- (5) Install air cleaner and/or horn housing.

h. Accelerator Pedal Adjustment.

- (1) Remove accelerator rod to bellcrank lever attaching nut.
- (2) Push accelerator rod to wide open throttle position and hold pedal against pedal stop located on floor panel.
- (3) Push and hold down bellcrank lever to wide open position.
- (4) Adjust swivel on accelerator rod until it freely enters hold in bellcrank lever.
- (5) Release linkage and insure that the throttle lever returns to idle position.
- (6) Install nut which secures accelerator rod to bellcrank lever.

2-37. Removal.

a. Fuel Tank.

- (1) Disconnect battery cable from battery negative terminal.

WARNING

During removal operation, do not allow sparks or open flame near fuel tank.

- (2) Place a suitable container beneath drain plug and completely drain. Reinstall drain plug.
- (3) Disconnect fuel filler hose from fuel tank neck.
- (4) Disconnect fuel indicator electrical cable.
- (5) Disconnect fuel outlet pipe from fuel tank connection.
- (6) Disconnect fuel tank ventilation tube.
- (7) Support fuel tank and remove two nuts and lock washers which secure fuel tank supporting straps to body brackets.
- (8) Disconnect supporting strap attaching bolts from body bracket and remove fuel tank.

b. Fuel Pump (Fig. 2-16)

- (1) Disconnect fuel, vacuum and vent lines from fuel pump.
- (2) Remove two nuts and lock washers securing fuel pump to engine block.
- (3) Remove fuel pump and gasket from engine. Discard gasket.

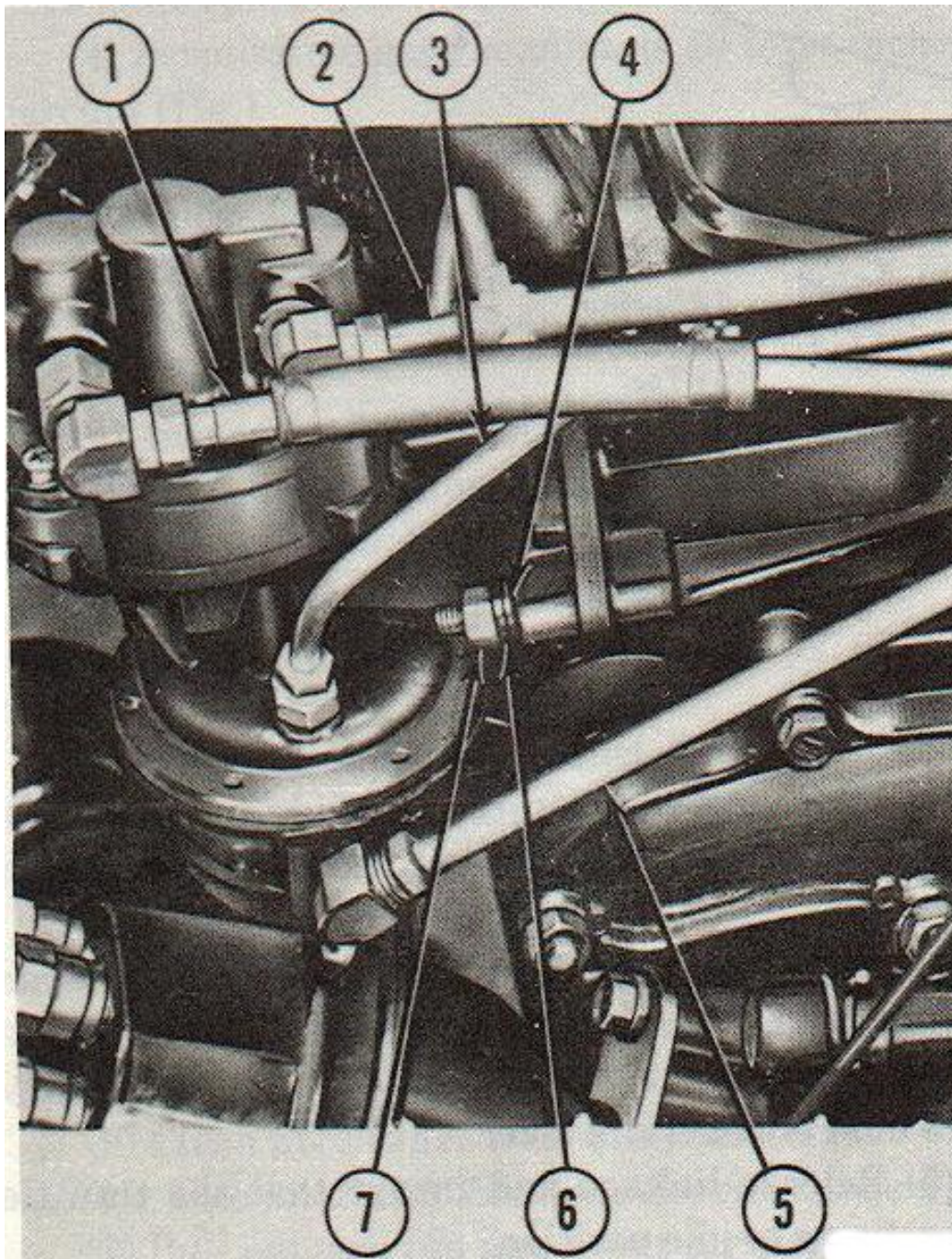

Figure 2-16. Removing fuel pump

- 1 Vacuum inlet line
- 2 Vacuum outlet line

- 3 Fuel vent line
- 4 Flat washer
- 5 Fuel outlet line
- 6 Lock washer
- 7 Nut

c. Fuel Filter.

- (1) Disconnect rubber fuel lines connecting inline fuel filter.
- (2) Remove fuel filter and discard.

d. Crankcase Ventilation Valve. (Fig 2-17)

- (1) Remove crankcase ventilation valve hose clamp at valve intake manifold adapter and pull hose from valve.
- (2) Remove valve from adapter by screwing counter-clockwise.

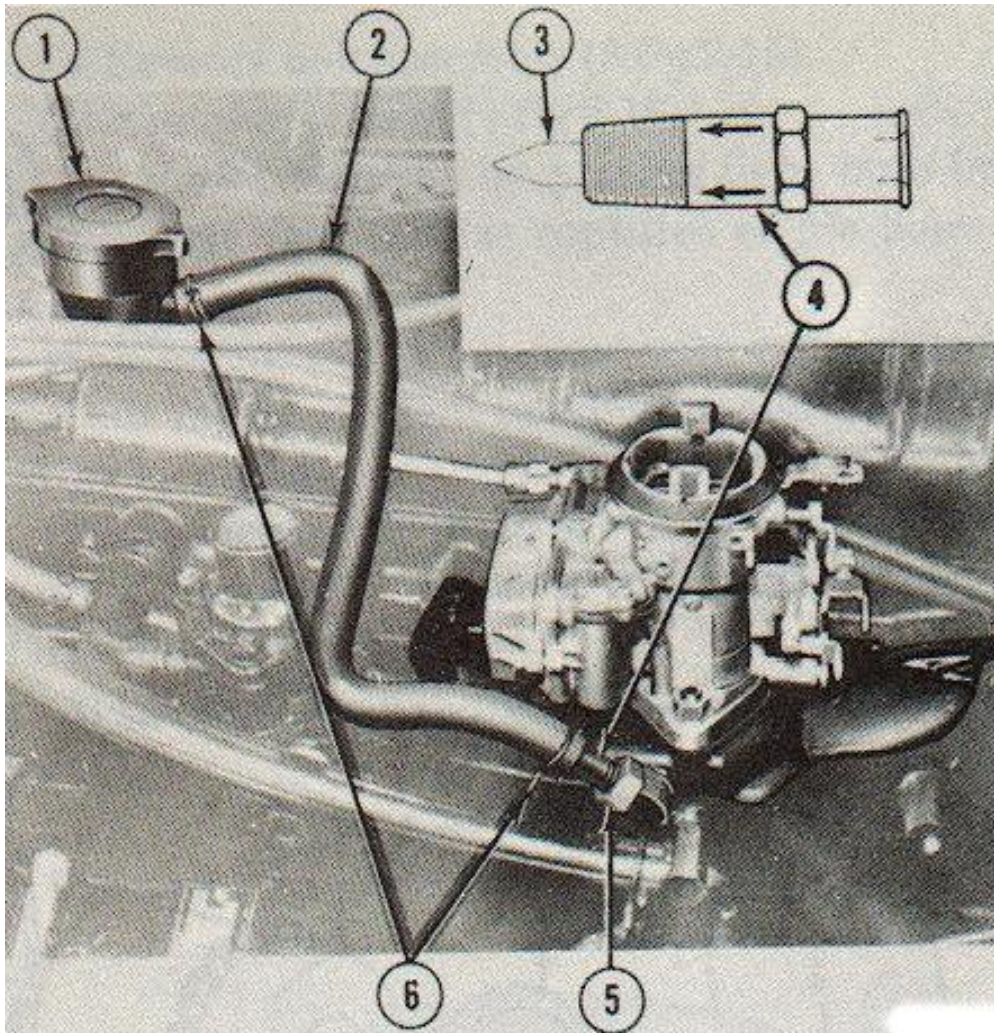

Figure 2-17. Crankcase ventilation valve.

- 1 Oil filler spout
- 2 Ventilation hose
- 3 Plunger
- 4 Ventilation valve
- 5 Adapter
- 6 Hose clamp

e. Carburetor.

- (1) Disconnect battery ground cable from battery negative terminal.
- (2) Place a rag beneath fuel line at rear of carburetor to absorb spillage and disconnect fuel inlet line from carburetor.
- (3) Loosen clamp (20 fig 2-15) which retains air cleaner and/or air horn housing to carburetor air horn and remove air cleaner and/or air horn housing.
- (4) Loosen choke control wire retaining screw on side of carburetor.
- (5) Loosen choke cable clamp retaining screw and pull choke cable through clamp.
- (6) Disengage and remove accelerator linkage return spring on side of carburetor.
- (7) Remove nut which secures accelerator cable to carburetor throttle shaft and disconnect cable from shaft.
- (8) Remove two nuts (2 fig 2-18), lock washers (3 fig 2-18) and flat washers (4 fig 2-18).
- (9) Remove carburetor assembly (1 fig 2-18) and gasket (5) from intake manifold.

f. Governor.

- (1) Disconnect vacuum hose (9 fig 2-18) from governor.
- (2) Loosen clamp (20 fig 2-15) and remove air horn (17 fig 2-15) from carburetor.
- (3) Loosen screws attaching choke cable and remove cable.
- (4) Remove accelerator retracting spring.
- (5) Remove throttle linkage by removing nut on linkage.
- (6) Loosen fuel line fitting and remove fuel line from carburetor.
- (7) Remove two nuts (2 fig 2-18), lock washers (3 fig 2-18) and flat washers (4 fig 2-18). Lift carburetor (1 fig 2-18) from governor.
- (8) Remove carburetor base gasket.
- (9) Remove governor (7 fig 2-18) and base gasket (5) from manifold.

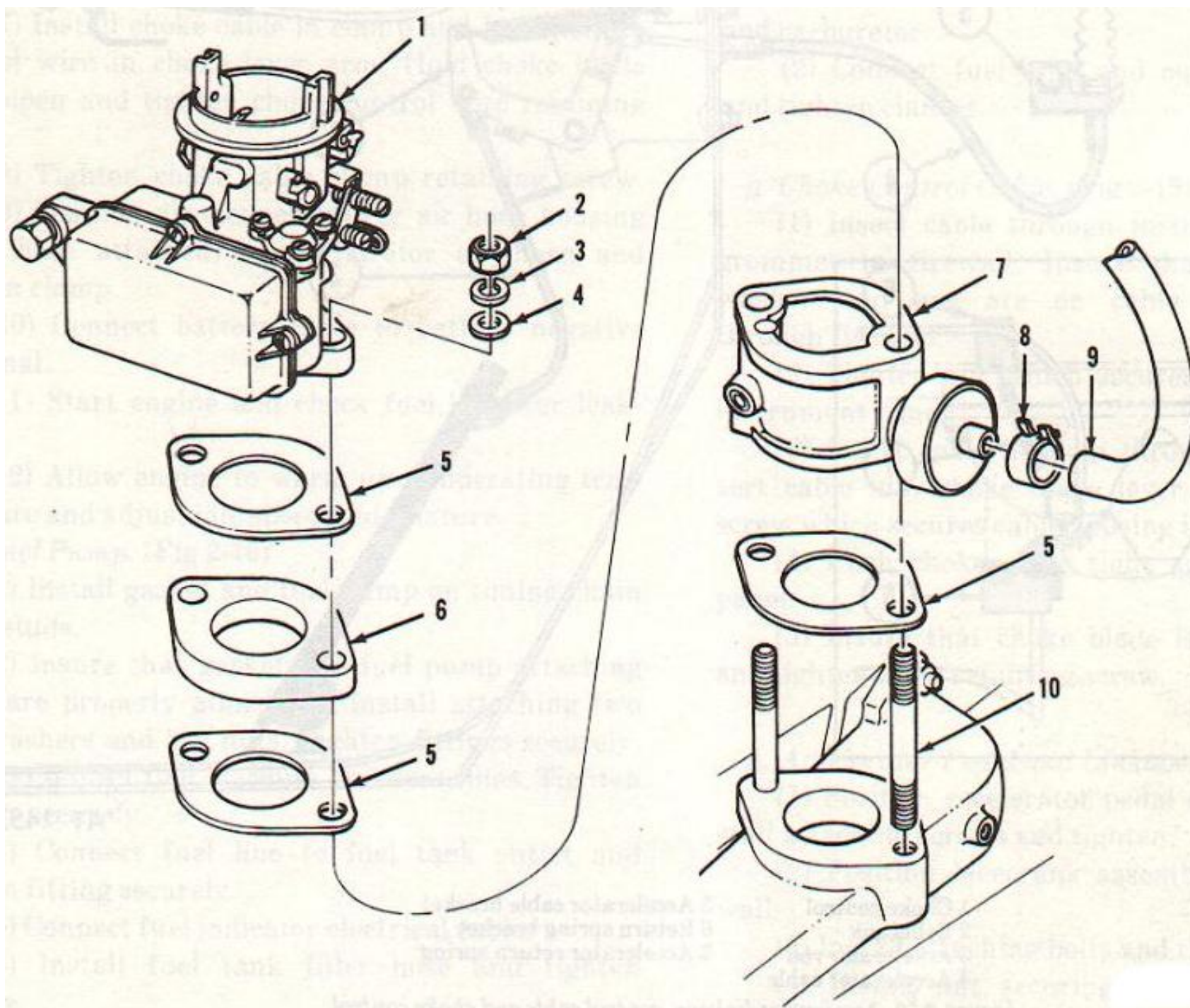

Figure 2-18. Carburetor and governor removal.

1 Carburetor 6 Spacer

2 Nut	7 Governor
3 Lock washer	8 Clamp
4 Flat washer	9 Vacuum hose
5 Gasket	10 Stud

g. Choke Control Cable.

- (1) Loosen screw which secures choke control wire (1 fig 2-19) to choke blade swivel.
- (2) Loosen cable clamp screw and lock washer cable from clamp.
- (3) Remove nut and lock washer which secure cable behind instrument panel.
- (4) Remove cable by pulling assembly through firewall grommet and instrument panel.

h. Accelerator Pedal and Linkage.

- (1) Remove accelerator linkage return spring (7 fig 2-19) from carburetor throttle lever and rear rocker arm support bracket.
- (2) Remove nut which secures accelerator cable to throttle lever. Disconnect cable from lever.
- (3) Remove retainer clip attaching accelerator cable housing to manifold. Remove cable from bracket.
- (4) Remove bellcrank return spring attached to inside firewall.
- (5) Remove cotter key securing accelerator cable to bellcrank.
- (6) Remove retainer clip securing accelerator cable to inside firewall.
- (7) Remove nut connecting accelerator rod to bellcrank assembly. Remove bolts attaching bell-crank to firewall. Remove bellcrank assembly (2 fig 2-19).
- (8) Remove two phillips screws which secure accelerator pedal to floor panel. Remove accelerator pedal.

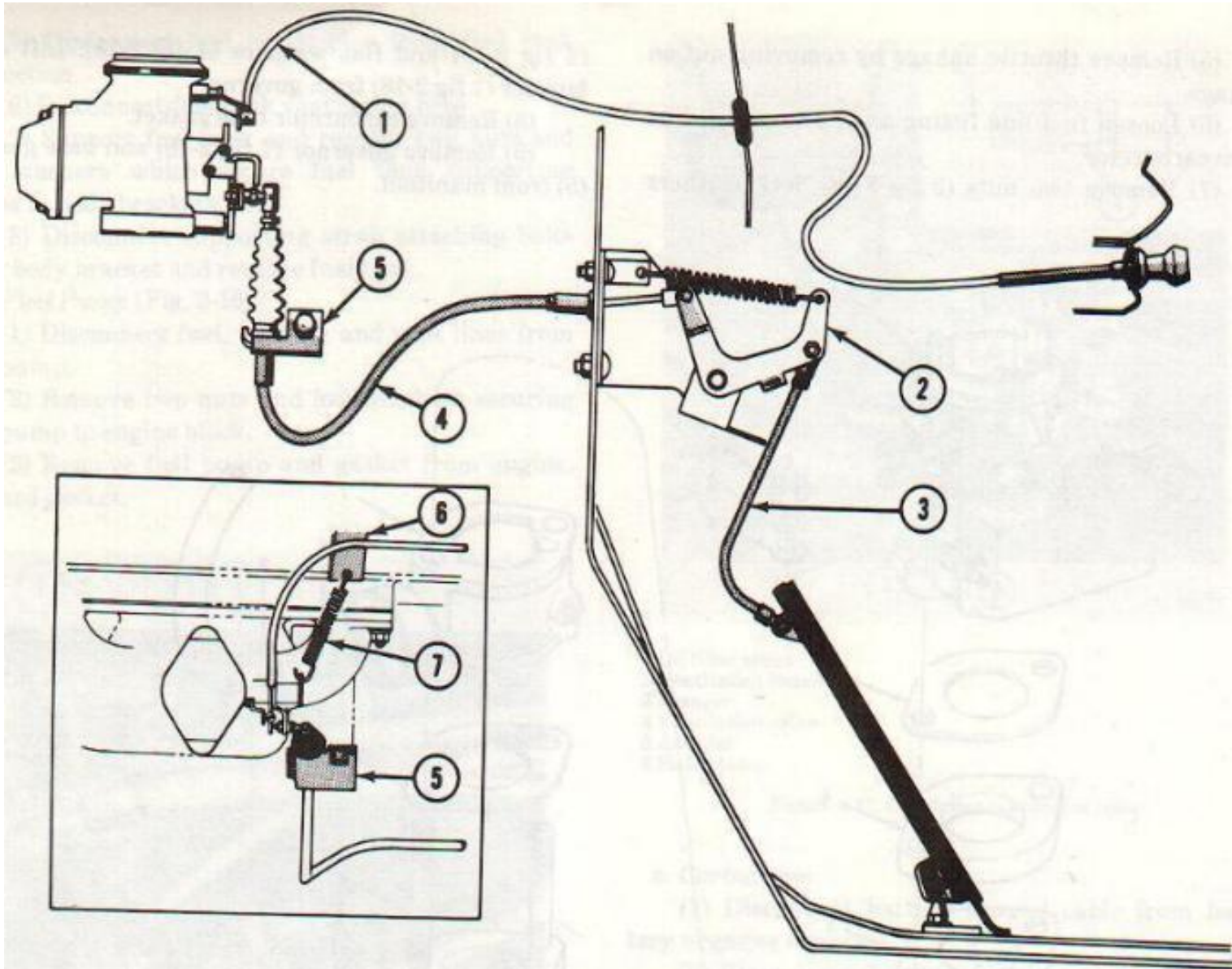

Figure 2-19. Accelerator linkage, control cable and choke control.

- 1 Choke control
- 2 Bellcrank
- 3 Accelerator rod
- 4 Accelerator cable
- 5 Accelerator cable bracket
- 6 Return spring bracket
- 7 Accelerator return spring

2-38. Cleaning and Inspection.

- a. Clean exterior of fuel tank and fuel tank brackets to insure that they are free of dirt, rust and corrosion. Spot paint required areas.
- b. Inspect fuel tank for cracks and dents.
- c. Inspect electrical wiring and connectors to insure that they are free of cracks, frayed insulation and that connections are secure; replace unserviceable wiring.
- d. Inspect fuel pipes for flow restricting kinks and corrosion.
- e. Inspect fuel pipe fittings for stripped threads. f Clean gasket materiel or sealant from mating surfaces with cleaning solvent or mineral spirits base paint thinner.
- g. Clean and lightly oil threads of all attaching bolts and nuts,
- h. Tighten intake manifold nuts.

2-39. Installation.

a. Governor. (fig 2-18)

- (1) Install governor and gasket on intake manifold studs.
- (2) Install carburetor and gasket on intake manifold studs.
- (3) Install the two lock washers, hex nuts and tighten to 14-18 lbs-ft.
- (4) Connect fuel line to carburetor.
- (5) Connect throttle linkage to carburetor.
- (6) Connect accelerator retracting spring.
- (7) Connect choke cable to carburetor.
- (8) Tighten C-clamp securing air horn housing to carburetor.

b. Carburetor. (Fig 2-18)

- (1) Install carburetor gasket on intake manifold studs.
- (2) Install carburetor on intake manifold studs.
- (3) Install lock washers and nuts on studs and tighten to 14-18 lbs-ft.
- (4) Connect fuel line to carburetor and tighten.
- (5) Install accelerator cable and carburetor throttle shaft and secure with nut.
- (6) Install accelerator linkage return spring on side of carburetor.
- (7) Install choke cable in clamp and insert choke control wire in choke lever arm. Hold choke blade fully open and tighten choke control wire retaining screw.
- (8) Tighten choke cable clamp retaining screw.
- (9) Position air cleaner and/or air horn housing (with hose attached) on carburetor air horn and tighten clamp.
- (10) Connect battery cable to battery negative terminal.
- (11) Start engine and check fuel lines for leakage.
- (12) Allow engine to warm up to operating temperature and adjust idle speed and mixture.

c. Fuel Pump. (Fig 2-16)

- (1) Install gasket and fuel pump on timing chain cover studs.
- (2) Insure that gasket and fuel pump attaching holes are properly alined and install attaching two lock washers and hex nuts. Tighten fittings securely.
- (3) Connect fuel, vacuum and vent lines. Tighten fittings securely.
- (4) Connect fuel line to fuel tank outlet and tighten fitting securely.

- (5) Connect fuel indicator electrical cable.
 - (6) Install fuel tank filler hose and tighten clamps.
 - (7) Install vent line on fuel tank.
 - (8) Connect battery cable to battery negative terminal,
- d. Fuel Tank.

- (1) Position tank in brackets. Connect supporting strap attaching bolts in brackets and install lock washers and hex nuts. Do not tighten.
- (2) Position anti-squeak strips on bottom of fuel tank under supporting straps.
- (3) Tighten supporting strap bolts to 20-30 lbs-ft.
- (4) Connect fuel line to fuel tank outlet and tighten fitting securely.
- (5) Connect fuel indicator electrical cable.
- (6) Install fuel tank filler hose and tighten clamps.
- (7) Install vent line on fuel tank.
- (8) Connect battery cable to battery negative terminal.

e. Air Cleaner. (Fig 2-14, 2-15)

- (1) Position air cleaner and/or air horn housing on carburetor air horn.
- (2) Tighten air cleaner clamp screw securely.
- (3) Connect hose from carburetor air horn housing and/or air cleaner to crankcase breather pipe. Tighten clamp screw securely.

f. Fuel Filter. (Fig 2-11)

- (1) Install fuel filter in-line between fuel pump and carburetor.
- (2) Connect fuel inlet and outlet lines to filter and tighten clamps.

g. Choke Control Cable. (Fig 2-19)

- (1) Insert cable through instrument panel and grommet in firewall. Insure that attaching sock washer and nut are on cable before inserting through firewall.
- (2) Tighten nut which secures cable housing to instrument panel.
- (3) Insert cable housing through clamp and insert cable into choke blade lever retainer. Tighten screw which secures cable housing in clamp.
- (4) Push choke cable tight against instrument panel.
- (5) Insure that choke blade is completely open and tighten cable retaining screw,

h. Accelerator Pedal and Linkage. (Fig 2-19)

- (1) Position accelerator pedal on floor panel. Install attaching screws and tighten.
- (2) Position bellcrank assembly on inside firewall.
- (3) Install attaching bolts and tighten.
- (4) Install nut securing accelerator pedal rod to bellcrank assembly. Tighten nut.
- (5) Install retainer clip securing accelerator cable to insides firewall.
- (6) Install cotter key securing accelerator cable to bellcrank.
- (7) Install bellcrank return spring to bracket on inside firewall.
- (8) Install retainer clip securing accelerator cable housing to manifold.
- (9) Install nut which secures accelerator cable in throttle lever.
- (10) Adjust linkage as outlines in paragraph 2-39h and install accelerator cable in throttle lever.
- (11) Connect accelerator linkage return spring on side of carburetor.

i. Crankcase Ventilation Valve.

- (1) Install new crankcase ventilation valve into manifold adapter.
- (2) Install hose from rocker arm cover to crankcase ventilation valve. Tighten clamp securely.

Section XII. MAINTENANCE OF EXHAUST SYSTEM

2-40. General.

The exhaust system consists of the exhaust manifold, exhaust pipe, exhaust pipe extension, muffler and tail pipe together with the necessary gaskets, hangers, brackets, clamps, bolts and lock washers.

2-41. Maintenance and Adjustment.

Refer to TM 9-2320-244-10 for daily maintenance inspection procedures. Inspect system for cracks, holes, broken hangers and brackets. Adjust hangers and brackets to prevent contact between the exhaust system and body or frame.

NOTE

Production vehicles are equipped with a one piece exhaust pipe. A two piece, exhaust pipe and exhaust pipe extension, is required for service replacement.

2-42. Removal.

a. Tail Pipe Hanger and Clamp. (Fig 2-20)

- (1) Remove hex nut, lock washer and bolt from tail pipe clamp.
- (2) Remove hex nut and bolt from hanger insulator to frame bracket.
- (3) Remove tail pipe hanger.

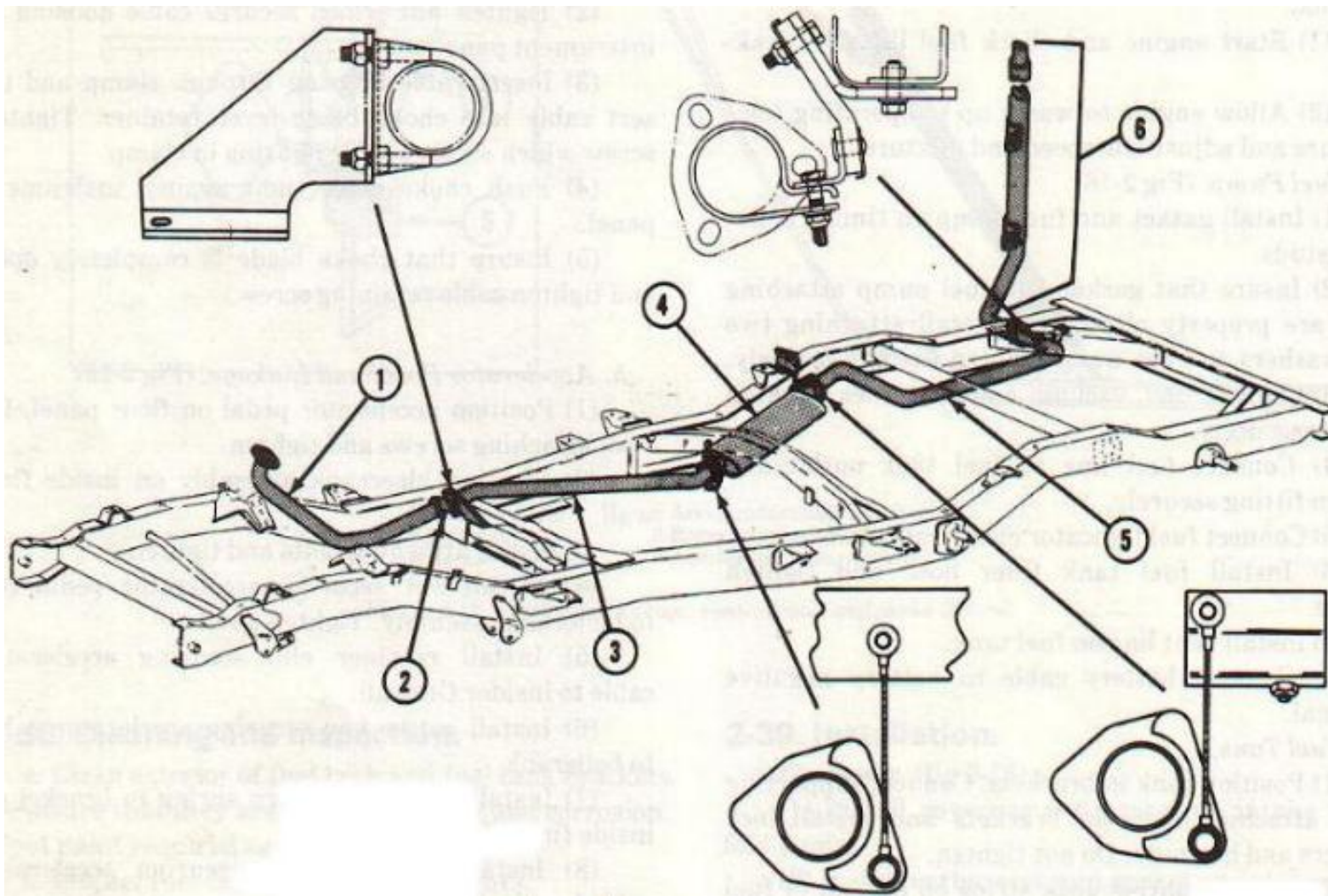

Figure 2-20. Exhaust system.

- 1 Exhaust pipe
- 2 Clamp
- 3 Exhaust pipe extension
- 4 Muffler
- 5 Tail pipe
- 6 Deep water fording exhaust pipe

b. Muffler Hanger Straps.

- (1) Remove nuts, lock washers and bolts from muffler inlet and outlet pipe flanges. Remove cotter pins securing hanger straps to frame and cross-member.
- (2) Remove front and rear muffler hanger straps.

c. Tail Pipe.

- (1) Remove hex nut, lock washer and bolt from tail pipe hanger clamp.
- (2) Remove three bolts which secure tail pipe to muffler outlet pipe companion flange.
- (3) Spread tail pipe clamp sufficiently to allow removal of tail pipe and remove tail pipe assembly.

d. Muffler Assembly.

- (1) Remove three bolts which secure tail pipe to muffler outlet pipe companion flange.
- (2) Remove three bolts which secure muffler inlet pipe to exhaust pipe companion flange and remove muffler assembly.
- (3) Discard companion flange gaskets.

e. Exhaust Pipe. (One Piece)

- (1) Remove two nuts and bolts attaching exhaust pipe to exhaust manifold.
- (2) Remove bolts and nuts which secure exhaust pipe to muffler inlet pipe companion flange.
- (3) Remove U-bolt clamp attaching frame cross-member bracket, near transmission.
- (4) Lower exhaust pipe and remove pipe. Discard gasket.

f Exhaust Pipe Extension.

- (1) Remove two nuts and bolts which secure exhaust pipe to exhaust manifold. Discard gasket.
- (2) Remove three bolts and nuts securing exhaust pipe to exhaust pipe extension flange. Discard gasket.
- (3) Remove exhaust pipe U-bolt clamp bracket at frame crossmember, near transmission.
- (4) Remove three bolts and nuts which secure exhaust pipe extension to muffler inlet pipe companion flange. Discard gasket.
- (5) Remove exhaust pipe and exhaust pipe extension.

g. Exhaust Manifold. (Fig 2-21)

- (1) Remove two hex nuts, bolts and remove exhaust pipe.
- (2) Remove ten hex nuts and flat washers and remove exhaust manifold.

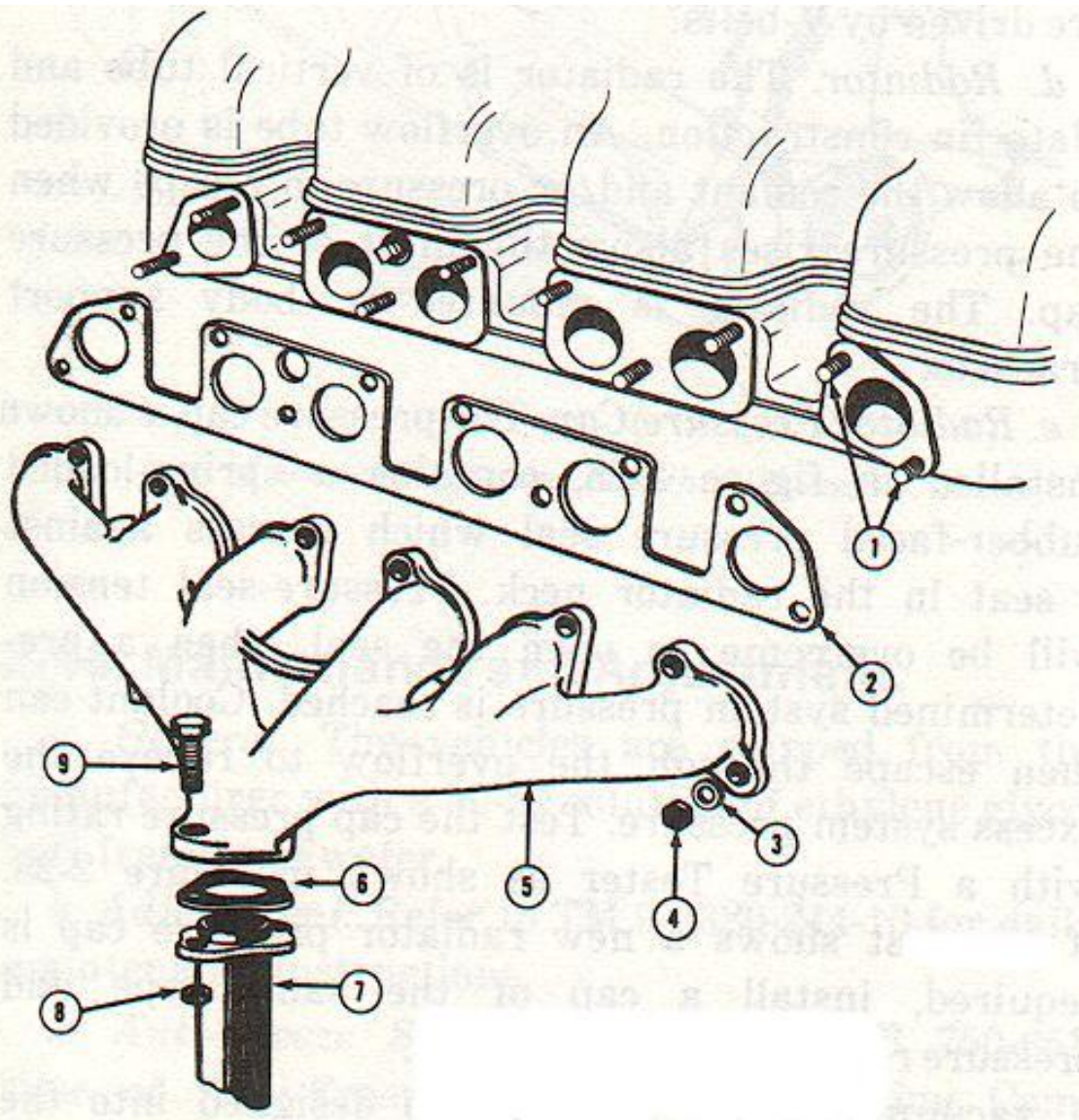

Figure 2-21. Exhaust manifold

- 1 Manifold studs
- 2 Exhaust manifold gasket
- 3 Flat washer
- 4 Hex nut
- 5 Exhaust manifold
- 6 Exhaust. pipe gasket
- 7 Exhaust pipe
- 8 Hex nut

2-43. Cleaning, Inspection and Repair.

- a. Clean all mating surfaces of gasket material, rust scale and corrosion with cleaning solvent, mineral spirits base paint thinner, or by brushing. If scraping is required, use extreme care not to nick, scratch or gouge mating surfaces.
- b. Clean and oil all attaching bolts and nut threads.
- c. Inspect all threaded holes; clean and retap as required.
- d. Replace exhaust manifold, pipes, muffler and hangers if they are cracked or broken

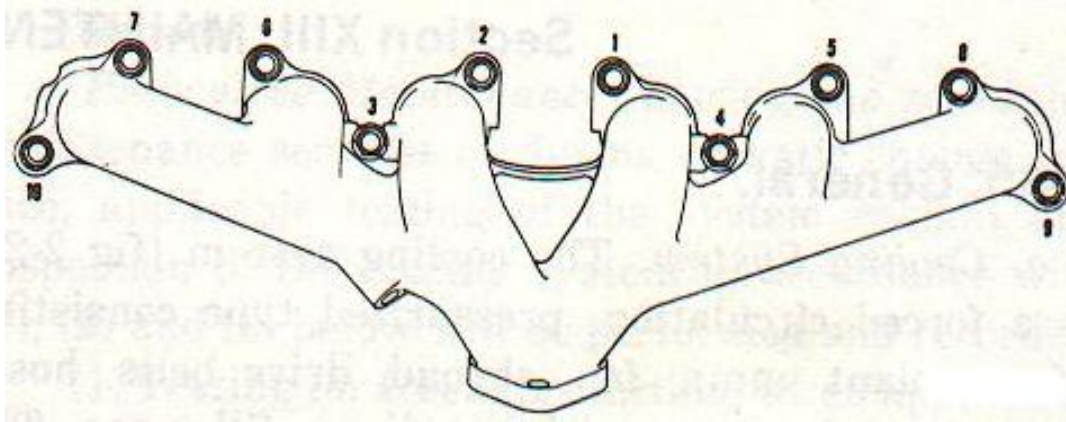

Figure 2-22. Exhaust manifold nut tightening sequence.

2-44. Installation.

a. Exhaust Manifold.

- (1) Install new exhaust manifold gasket.
- (2) Position exhaust manifold on cylinder head assembly.
- (3) Install ten flat washers and attaching nuts. Tighten to 25-30 lbs-ft. in sequence as shown in figure 2-22.
- (4) Position new exhaust pipe gasket on exhaust pipe flange.
- (5) Connect exhaust pipe to manifold. Position exhaust pipe flange to manifold flange and install two bolts and hex nuts, Tighten nuts to 20-30 lbs-ft.

b. Exhaust Pipe (One Piece).

- (1) Position new gasket and exhaust pipe to exhaust manifold.
- (2) Install two attaching bolts and nuts which secure exhaust pipe flange to exhaust manifold.
- (3) Insure that exhaust pipe flange and gasket are properly aimed and tighten attaching nuts to 20-30 lbs-ft.
- (4) Install gasket and Connect muffler flange to exhaust pipe flange; install bolts and nuts. Tighten to 20-30 lbs-ft.

c. Exhaust Pipe Extension.

- (1) Position new gasket and exhaust pipe to exhaust manifold.
- (2) Install two attaching bolts and nuts which secure exhaust pipe flange to exhaust manifold.
- (3) Install new gasket and connect exhaust pipe to exhaust pipe extension flange; install bolts and nuts and tighten to 20-30 lbs-ft.
- (4) Install new gasket and connect exhaust pipe extension flange to muffler companion flange.
- (5) Install bolts and nuts and tighten to 20-30 lbs-ft.

(6) Install exhaust pipe U-bolt clamp, two nuts and lock washers, and secure to frame crossmember bracket.

d. Muffler Assembly.

(1) Install new gasket and position muffler inlet pipe to exhaust pipe.

(2) Position muffler outlet pipe in muffler hanger. Install bolt and nut to hold muffler in position. Do not tighten.

(3) Install three bolts and hex nuts which secure muffler inlet pipe to exhaust pipe companion flange. Aline muffler assembly so that it is parallel to frame side rail. Aline companion flanges and tighten attaching bolts evenly to 20-30 lbs-ft.

(4) Tighten front and rear muffler hanger attaching bolts.

e. Tail Pipe.

(1) Spread tail pipe clamp sufficiently to allow installation of tail pipe assembly.

(2) Install clamp, bolt, lock washer and nut in clamp to hold tail pipe. Do not tighten.

(3) Install new gasket and position tail pipe to muffler outlet pipe.

(4) Install three bolts which secure tail pipe to muffler outlet pipe companion flanges. Aline companion flanges.

(5) Insure that tail pipe is properly aimed and tighten bolts to 20-30 lbs-ft.

(6) Tighten tail pipe clamp bolt and nut.

f. Muffler Hanger Straps.

(1) Position front and rear muffler hanger straps onto clevis pins located on crossmember and frame bracket. Install two cotter pins and secure.

(2) Position hanger to muffler inlet and outlet pipe. Install bolt, lock washer and nut and tighten.

g. Tail Pipe Hanger.

(1) Position insulator to frame bracket assembly and install bolt and nut. Tighten securely.

(2) Position tail pipe assembly to hanger and install lower clamp, bolt, lock washer and nut. Tighten securely.

Section XIII. MAINTENANCE OF COOLING SYSTEM

2-45. General.

a. Cooling System. The cooling system (fig 2-23) is a forced circulation, pressurized type consisting of a coolant pump, fan, shroud, drive belts, hoses radiator and a pressurizing radiator filler cap. The coolant is drawn from the radiator by the water pump and circulated through the cylinder block and head. After circulation throughout the engine, the coolant is forced through an outlet past the thermostat, and back into the radiator assembly. As the coolant passes through the radiator, it is cooled by air drawn through the radiator by the fan and the forward motion of the vehicle. When because of insufficient operating temperature, the thermostat is closed, constant circulation of the coolant is provided through the engine by a bypass hose connecting the thermostat housing with the intake side of the coolant pump assembly.

b. Coolant Pump. The coolant pump is a centrifugal vane impeller type. The bearings are permanently lubricated and are sealed to prevent the loss of lubricant, or the entry of dirt and water. The coolant pump requires no maintenance other than to make certain the air vent at the top of the housing, and the drain holes in the bottom do not become plugged with dirt and grease.

c. Fan. The fan is a four blade type with blades spaced equally. The fan is bolted to the coolant pump hub which is also used to retain the coolant pump fan pulley. The fan and coolant pump assembly are driven by V-belts.

d. Radiator. The radiator is of vertical tube and plate fin construction. An overflow tube is provided to allow the coolant and/or pressure to escape when the pressure rises above the limit of the pressure cap. The radiator is mounted to body support brackets.

e. Radiator Pressure Cap. The pressure cap is shown installed in figure 2-28, contains a spring-loaded rubber-faced pressure seal which presses against a seat in the radiator neck. Pressure-seal tension will be overcome to open the seal when a predetermined system pressure is reached. Coolant can then escape through the overflow to relieve the excess system pressure. Test the cap pressure rating with a Pressure Tester as shown in figure 2-28. If the test shows a new radiator pressure cap is required, install a cap of the same type and pressure rating of 15 psi specified.

A vacuum-release valve is also designed into the cap to prevent excessive vacuum particularly when the system cools. The vacuum-release seal is held against its seat by a vacuum-release-seal spring. Spring pressure is overcome and the vacuum-release seal opens if vacuum in excess of 1 psi develops. The pressure tester can also be used to test vacuum-pressure rating.

f. Fan Shroud. The fan shroud attaches to the rear of the radiator and envelopes the fan in such a way that, to the extent possible, all of the air moved by the fan passes through the radiator core

g. Thermostat. The thermostat is a spring and cartridge type, located in the thermostat housing, on top front end of intake manifold. The thermostat restricts the flow of coolant to the radiator until a predetermined temperature is obtained at which time it begins to open. When the coolant at the thermostat reaches the rated temperature of the thermostat, the thermostat valve will be fully opened. Refer to figure 2-23.

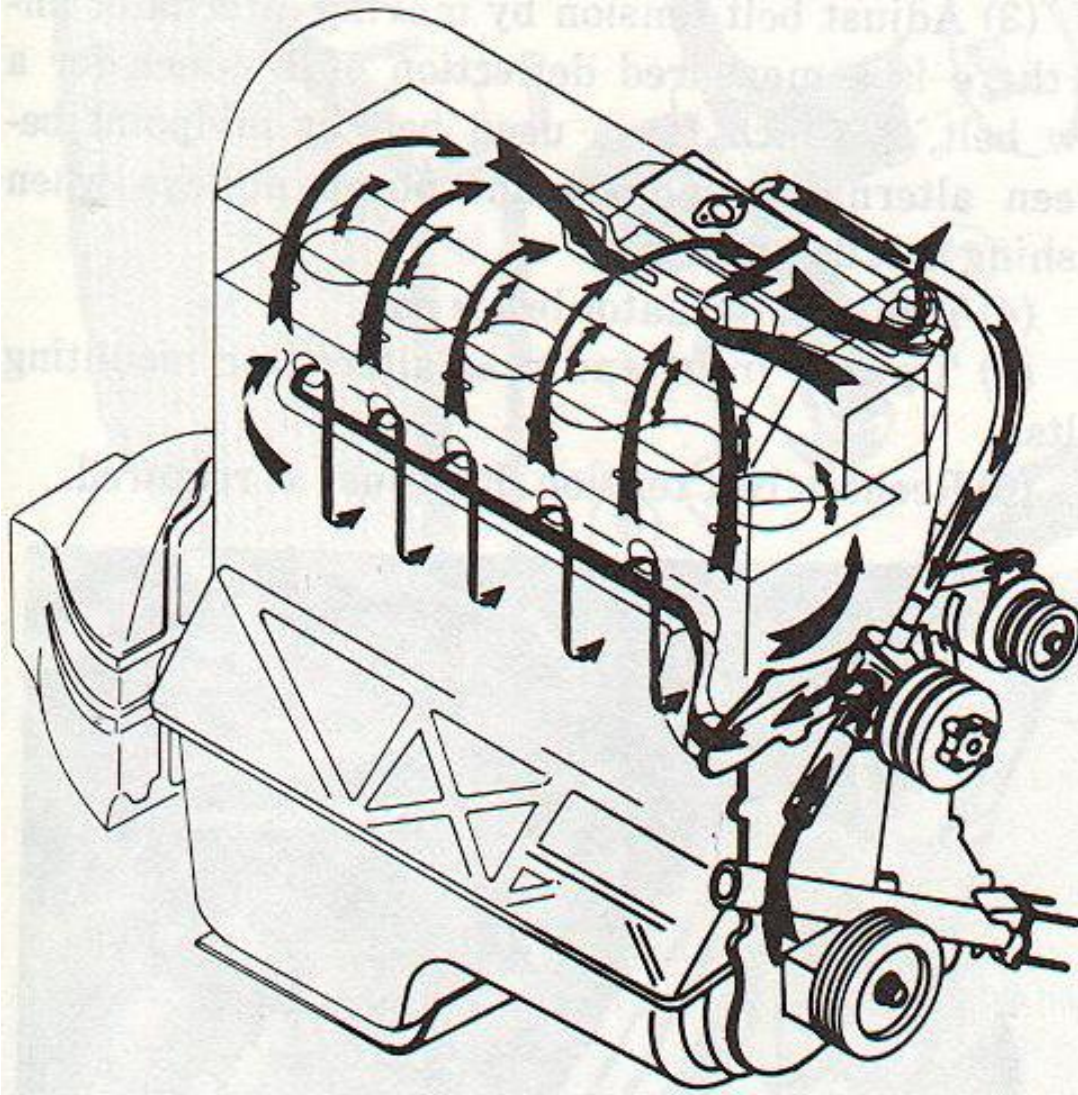

Figure 2-23. Coolant flow through engine

2-46. Maintenance and Adjustment.

- a. General. The vehicles are shipped from the manufacturer with a 50-50 solution of ethylene glycol anti-freeze and water.
- b. Adjustment. Refer to TM 9-2320-244-10 for daily maintenance instructions.
- c. Anti-Freeze Solutions, Refer to TB 750-651, Use of Anti-Freeze Solution for Cleaning Compounds in Engine Cooling Systems.
 - (1) Anti-Freeze inhibited solution, O-A-548, Type I or Heavy Duty MIL-A-46153, may be retained in the engine cooling system for a two year period from fill date.
 - (2) Arctic-type anti-freeze, MIL-A-11755 will be replaced on an annual basis, preferably at the beginning of the cold weather season.
 - (3) In climates where temperature does not fall below +32°F and where maximum engine cooling is required, the use of water with dissolved inhibitor (FSN 6850-753-4967 Inhibitor, Corrosion Liquid Cooling System) is authorized. When temperature is expected to fall below +32°F, antifreeze protection in accordance with (d) below is required.

NOTE

In an emergency, where anti-freeze or inhibited water is not available, water is authorized on a temporary basis, with the circumstances noted on DA Form 2408-14. At the earliest opportunity, necessary action will be taken to restore coolant to prescribed requirements.

d. Anti-Freeze Protection.

- (1) When cooling system protection is required for temperatures no lower than -55°F prepare solution in accordance with Table 2-10, For each two quarts of water used in preparing the solution, add and dissolve one ounce of corrosion inhibitor (FSN 6850-753-4967).
- (2) In areas where lowest temperature encountered is below -55 °F, use arctic-type anti-freeze MILA-11755.

CAUTION

Do not dilute arctic-type anti-freeze with water or inhibitor. It is ready for use as issued.

e. Preventive Maintenance, During the scheduled maintenance services or during climatic change service, applicable testing of the system coolant and inspection of the cooling system in accordance with (1), (2) and (3) below will be performed and recorded.

- (1) Testing for freeze protection, when applicable, by use of a combination anti-freeze and battery tester FSN 6630-169-1418 or anti-freeze tester (Arctic-type) FSN 6630-842-3217, as applicable.

NOTE

A freeze protection beyond the limits shown in Table 2-10 or below -55°F will require partial anti-freeze drain and replacement with water or inhibitor solution. Freeze protection must not exceed -55°F

- (2) Testing for reserve alkalinity by means of a test kit, FSN 6630-169-1506, color indication of the test kit will determine condition of the coolant and its potential corrosion protection until the next PM service.

NOTE

Do not use test kit at temperature below + 50°F.

- (3) Visual inspection for coolant cleanliness by withdrawing a small amount of coolant into a clean container, Visual examination will be made for excessive rust, foreign particles and/or sediment.

f. Engine Cooling System Cleaner. Engine cleaning compound FSN 6850-598-7328 for cooling Systems is designed to clean interiors of cooling systems, to neutralize residual cleaning acids, and to coat the interiors with silicate.

NOTE

The cleaning compound will be used only when necessary to clean heavily rusted or partially clogged cooling systems.

Table 2-10 Preparation of Ethylene Glycol Anti-Freeze Solutions

Lowest Estimated Temperature in Geographic Area	Pints of Ethylene Glycol Anti-freeze to be included in preparation of 1-gal. Anti-Freeze Solution.
+20°F	1-1/2
+10°F	2
0°F	2-3/4
-10°F	3-1/4
-20°F	3-1/2
-30°F	4
-40°F	4-1/4
-50°F	4-1/2
-55°F	4-3/4

g. Draining Radiator.

(1) Place an appropriate container under radiator drain plug located on the right rear lower corner of radiator body.

WARNING

Use extreme care in removing radiator cap when engine is hot. Turn cap to first detent and allow pressure to escape before removing radiator cap.

(2) Remove radiator cap.

(3) Remove drain plug at lower right side of radiator and allow radiator coolant to completely drain.

(4) Reinstall radiator drain plug and tighten.

h. Draining Cooling System.

(1) Place an appropriate container under side of cylinder block drain plug.

(2) Remove radiator cap and drain plug as described in (q) above.

(3) Remove drain plug from left side of cylinder block. Plug is located directly behind starting motor.

i. Filling Cooling System.

(1) Install drain plug in left side of cylinder block, and in lower right side of radiator assembly. Tighten radiator drain plug and cylinder block drain plug securely.

(2) Fill radiator with proper seasonal coolant solution to within 2-inches of filler opening.

(3) Install radiator cap. Start engine and run at idling speed.

(4) Carefully check radiator hose connections, coolant pump and thermostat housing attaching nuts and around cylinder heads for leakage.

(5) Carefully remove radiator cap and check coolant level. Fill as required to within 2-inches of filler opening.

(6) Install radiator cap and shut down engine.

j. Adjusting Drive Belt Tension. (Fig 2-24)

(1) Loosen front and rear alternator mounting bolts, and brace attaching bolt.

(2) Place a straightedge on the belt between alternator and coolant pump pulley.

(3) Adjust belt tension by moving alternator until there is a measured deflection of 1/2-inch for a new belt, 3/4-inch for a used belt at midpoint between

alternator and coolant pump pulleys when pushing belt down firmly.

(4) Tighten alternator brace bolt.

(5) Tighten front and rear alternator mounting bolts.

(6) Recheck belt tension. Readjust as required.

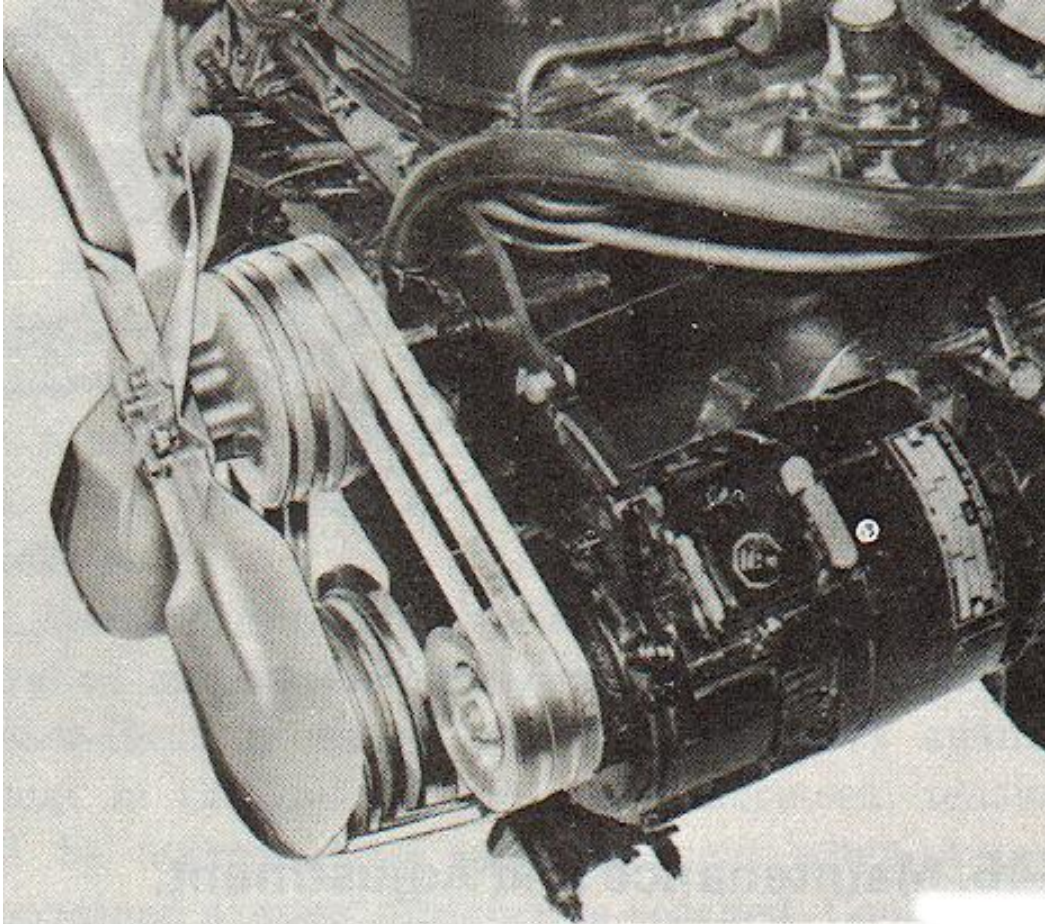

FIGURE 2-24. Fan Belts Installed

2-47. Removal.

Refer to paragraph 2-23 when the cooling system is removed as part of the power plant assembly and to figure 2-25 for removal of cooling system components.

a. Radiator Hoses.

(1) Drain radiator as outlined in paragraph 2-46g.

(2) Loosen hose clamps and remove inlet and outlet hoses.

b. Radiator.

(1) Drain radiator as outlined in paragraph 2. 46g.

- (2) Loosen inlet and outlet hose clamps and disconnect hoses from radiator.
- (3) Remove four bolts and remove radiator and shroud from body support.

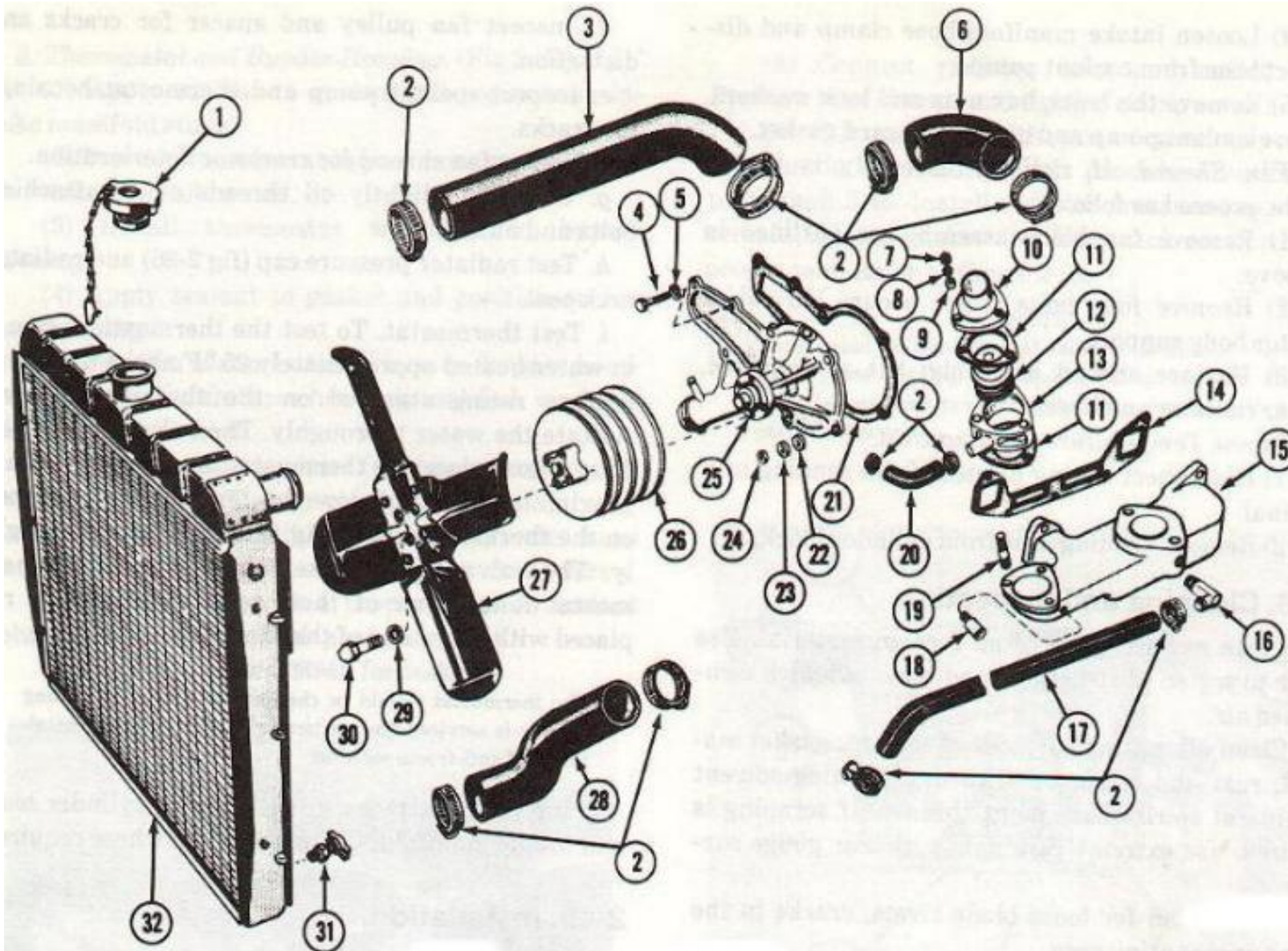

Figure 2-25. Engine cooling system.

1 Radiator cap	9 Flat washer	17 Water hose	25 Water pump
2 Hose clamp	10 Water outlet elbow	18 Temperature sending unit	26 Fan drive pulley
3 Upper radiator hose	11 Thermostat gasket	19 Stud	27 Cooling fan
4 Cap screw	12 Thermostat	20 Bypass hose	28 Lower radiator hose

5 Lock washer	13 Thermostat housing	21 Water pump gasket	29 Lock washer
6 Water hose	14 Intake manifold gasket	22 Flat washer	30 Cap screw
7 Nut	15 Intake manifold	23 Lock washer	31 Drain cock
8 Lock washer	16 Elbow	24 Nut	32 Radiator

c. Thermostat and Bypass Housing.

- (1) Drain radiator as outlined in paragraph 2-46g.
- (2) Loosen hose clamp and remove radiator inlet hose.
- (3) Remove three hex nuts and lock washers and remove water outlet elbow, gasket and thermostat assembly.
- (4) Loosen clamp and remove bypass hose.
- (5) Remove bypass housing and gasket (fig 2-25).

d. Fan, Fan Pulley and Drive Belts.

- (1) Loosen front and rear alternator mounting bolts, and alternator brace bolt. Rotate alternator toward engine assembly to relieve belt tension.
- (2) Remove drive belts from alternator, coolant pump and crankshaft pulleys.
- (3) Remove four fan to coolant pump attaching bolts and washers.
- (4) Remove fan, fan spacer and coolant pump pulley.

e. Coolant Pump.

- (1) Drain radiator as outlined in paragraph 2-46g.
- (2) Remove fan and coolant pump pulley as outlined in (d) above.
- (3) Loosen engine inlet (radiator outlet) hose clamp and disconnect hose from coolant pump housing.
- (4) Loosen intake manifold hose clamp and disconnect hose from coolant pump.
- (5) Remove the bolts, hex nuts and lock washers. Remove coolant pump and gasket. Discard gasket.

f Fan Shroud. If radiator assembly is in the vehicle, proceed as follows:

- (1) Remove fan blade assembly as outlined in (d) above.
- (2) Remove four bolts which secure shroud to radiator body support.
- (3) Remove shroud assembly; tilt as required, to clear radiator and hoses.

g. Engine Temperature Sending Unit.

- (1) Disconnect wiring harness from sending unit terminal.
- (2) Remove sending unit from cylinder block.

2-48. Cleaning and Inspection.

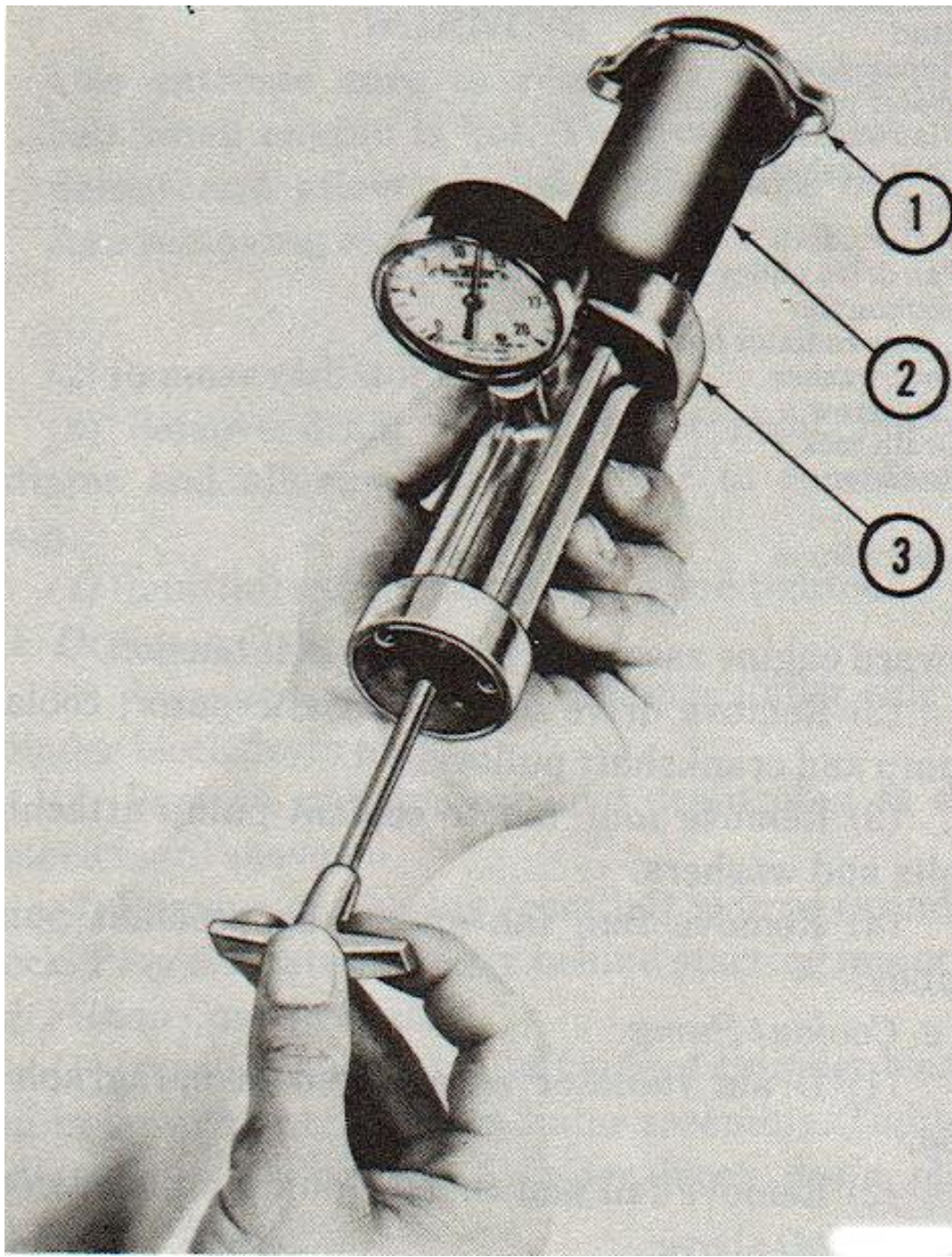

FIGURE 2-26. Testing Radiator Pressure Cap.

- 1 Radiator pressure cap
- 2 Adapter

3 Pressure tester

- a. Clean radiator core of all foreign material. Use water to soften obstructions and blow out with compressed air.
- b. Clean all mating surfaces of sealant, gasket material, rust and corrosion with dry cleaning solvent or mineral spirits base paint thinner. If scraping is required, use extreme care not to nick or gouge surfaces.
- c. Inspect fan for loose blade rivets, cracks in the blades or mounting area.
- d. Inspect fan pulley and spacer for cracks and distortion.
- e. Inspect coolant pump and thermostat housings for cracks.
- f. Inspect fan shroud for cracks or deterioration.
- g. Clean and lightly oil threads of all attaching bolts and nuts.
- h. Test radiator pressure cap (fig 2-26) and radiator neck seal.
- i. Test thermostat. To test the thermostat, place it in water heated approximately 25 °F above the temperature rating stamped on the thermostat valve. Agitate the water thoroughly. The valve should open fully. Next, place the thermostat in water heated approximately 10 ° F below the temperature stamped on the thermostat valve. Agitate the water thoroughly. The valve should close completely. If the thermostat fails either of these tests, it should be replaced with a new one of the same type and rating.

NOTE

The thermostat should be checked whenever the cooling system is serviced and particularly at the time of installation of anti-freeze solution.

- j. Inspect all attaching bolt holes in cylinder block and intake manifold. Clean and retap where required.

2-49. Installation.

a. Radiator and Shroud.

- (1) Position fan shroud to radiator.
- (2) Install shroud and radiator to radiator body support and secure with four cap screws, lock washers and flat washers.

b. Coolant Pump. (Fig 2-25)

- (1) Apply sealant and position gasket on coolant pump.
- (2) Install coolant pump and gasket to timing chain cover and secure with eight hex nuts, lock washers. Torque to 12-15 lbs-ft.
- (3) Install fan pulley and fan blade on coolant pump hub. Secure with four cap screws and lock washers. Torque to 12-15 lbs-ft.
- (4) Connect intake manifold hose to coolant pump housing nipple. Tighten clamp screw.
- (5) Connect radiator outlet (engine inlet) hose to coolant pump housing.
- (6) Position hose clamp and tighten clamp screw.
- (7) Install drive belts and tension in accordance with procedure outlined in paragraph 2-46.
- (8) Fill cooling system with the proper seasonal coolant solution in accordance with paragraph 2-46.

c. Fan, Fan Pulley and Drive Belts.

- (1) Install fan, fan pulley and drive belts as out lined in (c) above.
- (2) Tension belts in accordance with procedure outlined in paragraph 2-46j.

d. Thermostat and Bypass Housing. (Fig 2-27)

- (1) Apply sealant to gasket and position on in- take manifold studs.
- (2) Position thermostat bypass housing on gasket on intake manifold studs.
- (3) Install thermostat assembly in bypass housing.
- (4) Apply sealant to gasket and position on bypass housing.

- (5) Position water outlet elbow on bypass housing and secure with three hex nuts and lock washers. Tighten to 15-20 lbs-ft.
- (6) Connect radiator inlet (engine outlet) hose on water outlet elbow. Tighten clamp screw.
- (7) Connect bypass hose between cylinder head and thermostat bypass housing. Tighten clamp screw.
- (8) Fill radiator with a proper seasonal coolant solution in accordance with paragraph 2-46.
- (9) Start engine and check for leakage.

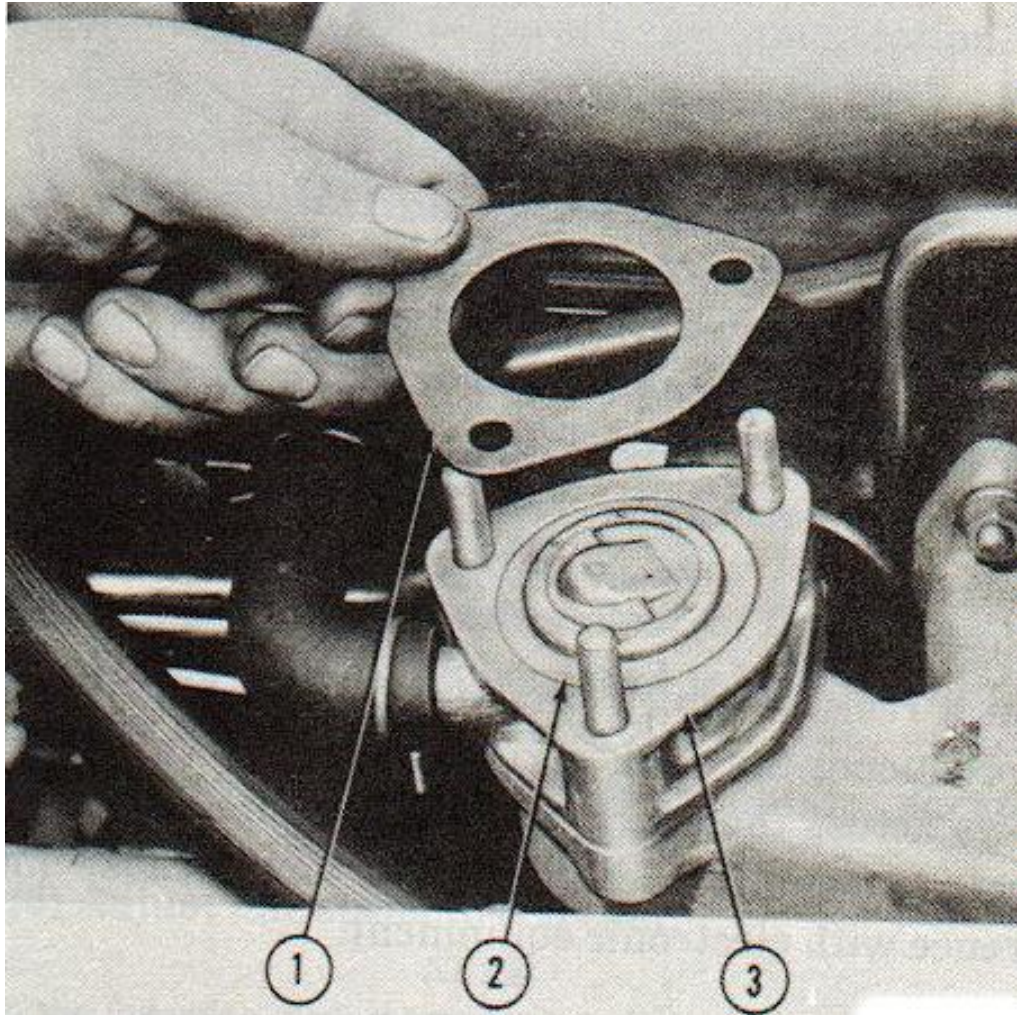

Figure 2-27. Thermostat Installation.

- 1 Gasket
- 2 Thermostat
- 3 Thermostat bypass housing

e. Radiator.

- (1) Carefully position radiator in vehicle. Check alinement of radiator, shroud and body support and reposition as required.
- (2) Install fan shroud and radiator to body support with four cap screws and lock washers.

(3) Connect radiator inlet and outlet hoses.

Position hose clamps and tighten clamp screws.

(4) Fill radiator with proper seasonal coolant

solution in accordance with procedure outlined in paragraph 2-46. Install radiator pressure cap making certain the cap gasket and filler neck seat provide a proper seal. Refer to figure 2-28.

NOTE

Hoses must be tight against radiator assembly, thermostat bypass housing and coolant pump housing. Hoses must be oriented prior to tightening clamps with hose part number on top.

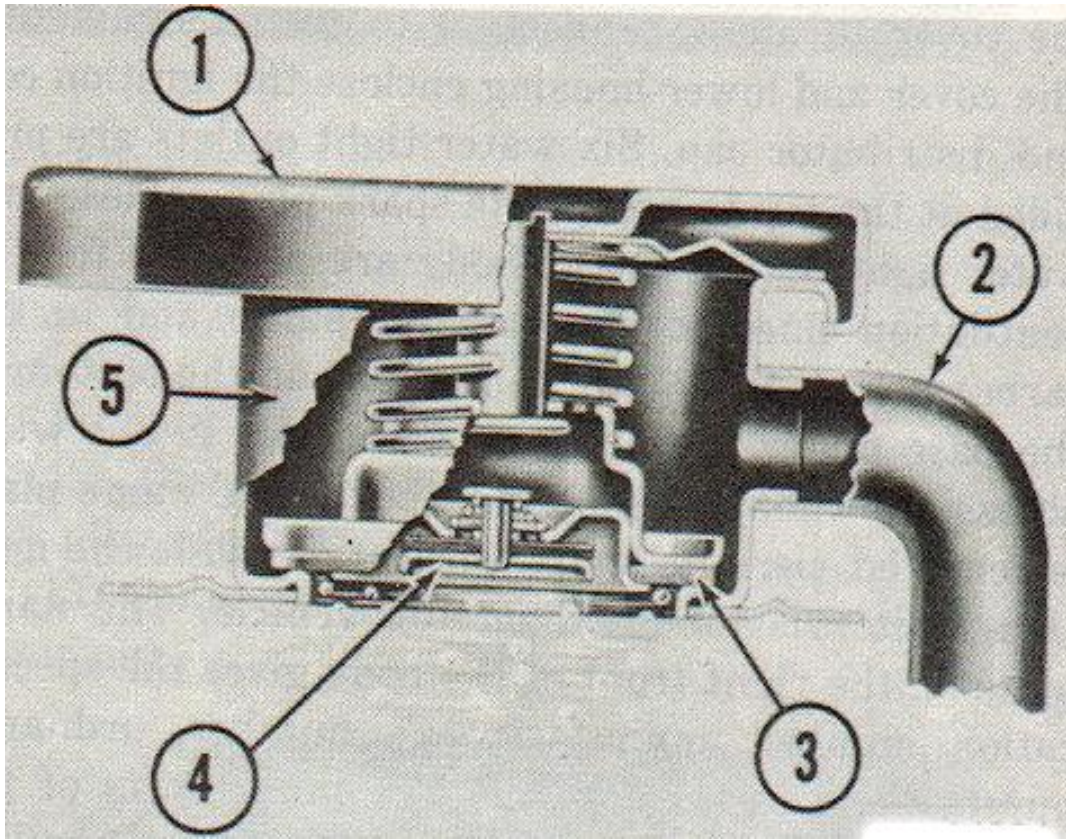

Figure 2-28 Radiator pressure cap installed.

1 Pressure cap

2 Overflow tube

3 Pressure seal

4 Vacuum release seal

5 Radiator neck

f Radiator Hoses.

- (1) Position inlet and/or outlet hose on radiator and coolant pump housing and/or thermostat housing.
 - (2) Position hose clamps and tighten clamp screw.
 - (3) Fill radiator with proper seasonal coolant solution in accordance with procedure outlined in paragraph 2-46.
- g. Engine Temperature Sending Unit.
- (1) Install sending unit in cylinder block.
 - (2) Connect wiring harness to sending unit terminals.

Section XIV. MAINTENANCE OF IGNITION SYSTEM

2-50. General.

a. The Ignition System. The ignition system consists of a combined distributor and coil assembly (ignitor), shielded spark plug cables, shielded spark plugs and the ignition switch, which it shares with other systems. The system, when properly installed and maintained, is waterproof and radio noise suppressed.

b. Ignitor. The ignitor (fig 2-29) is designed for 24-volt DC primary current and is a completely waterproof unit. A water tight access plug is provided on the cover to allow connection to test instruments. The cover and lower housing enclose the ignition coil and distributor cap. Six water tight outlets are provided at the top to accept the spark plug cables. Two water tight outlets in the body are provided for the ventilation lines to the vacuum pump and to the carburetor. A drain plug is provided on the bottom of the base under the primary connector. A felt wick, accessible when the pipe plug below the name plate is removed, permits shaft lubrication while the ignition ignitor is mounted on the vehicle. The name plate on the right front of the body gives the specification number, manufacturer's number, ordnance number and serial number. The main parts of the ignition ignitor are cap, rotor, ignition coil, ballast resistor, breaker plate (which includes points and condenser), cam, drive shaft and base. The ignition coil is a component part of the unit. The primary circuit consists of the coil primary winding, ballast resistor feed-through capacitor, breaker points, two cables and the ignitor condenser. The secondary circuit consists of coil secondary windings, bakelite cap, rotor and spark plug cable terminals.

The ignitor serves three main functions in the engine ignition system. It must close and open the primary circuit to produce the magnetic build-up and collapse in the ignition coil; time the magnetic buildup and collapse so that the resultant high voltage surges from the secondary circuit of the ignition coil will be produced at the proper time; and direct the high voltage surge to the correct spark plug.

c. Ignition Coil. The ignition coil which is used within the ignitor discharge system, mounts in the distributor housing. The coil is enclosed in a hermetically sealed, oil filled case. While the external appearance of the ignition coil is identical with a conventional coil, it is not interchangeable.

d. Spark Plugs and Spark Plug Cables. The spark plugs and spark plug cables are the military standard type. The cables are shielded with water-tight connectors. The spark plugs have 14 millimeter threads with a ½-inch reach. The spark plugs contain a resistor which provides greater electrode life by reducing the peak period of induced current that flows across the spark gap. The resistor also reduces electro-magnetic radiation that would cause interference with electronic equipment.

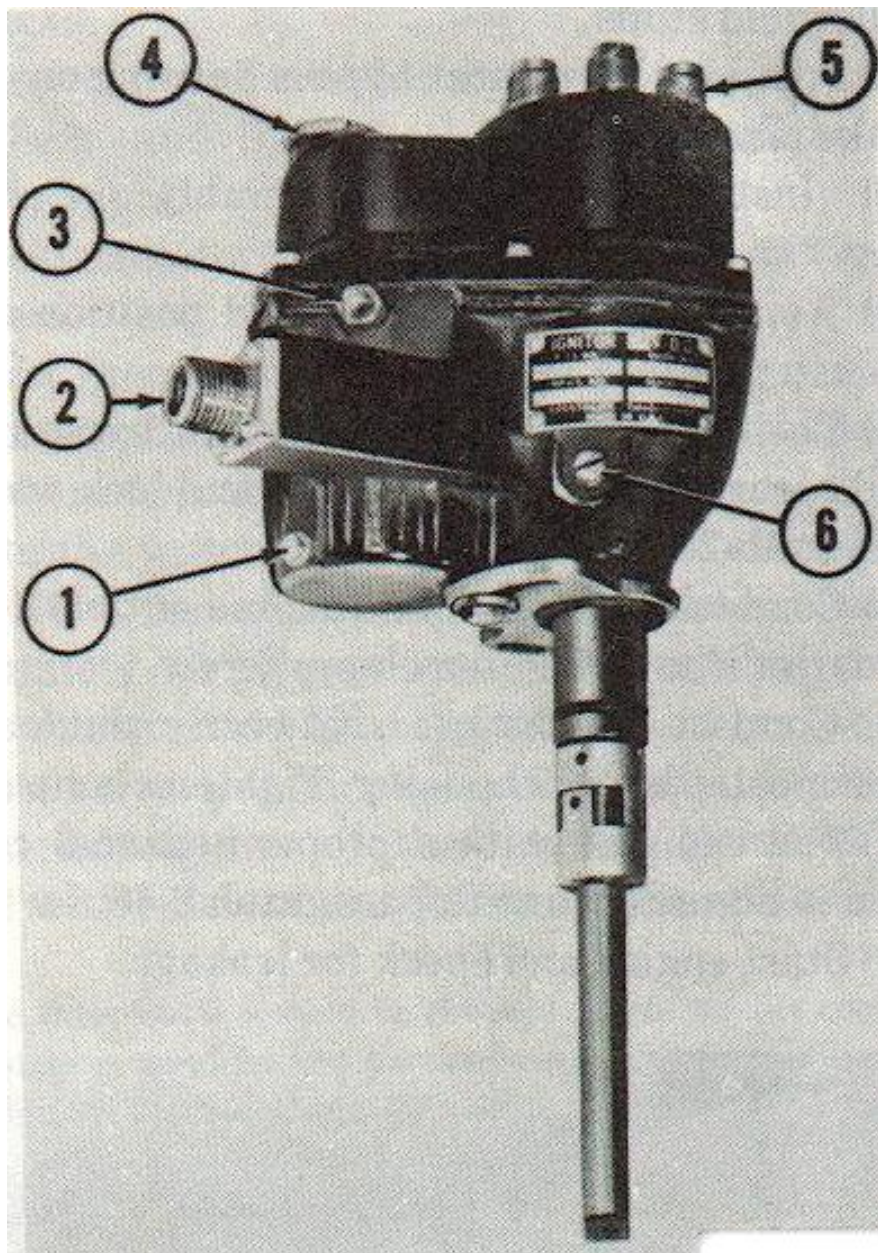

Figure 2-29. Ignitor.

- 1 Drain plug
- 2 Primary ignition feed
- 3 Vent to intake manifold
- 4 Access for ignition timing adapter
- 5 High tension tower
- 6 Access to lubricating wick

2-51. Maintenance and Adjustment.

a. Ignitor. (Fig 2-35)

- (1) Check the breaker point alinement for a full square contact. If not properly alined, bend the stationary contact bracket (6 fig 2-35) into proper closing alinement.
 - (2) Adjust contact gap from .020 plus or minus .002 . Adjust gap by loosening the adjusting screw (7 fig 2-35) and positioning the stationary contact until correct gap is obtained. Make certain the nylon rubbing block of the breaker arm is resting on the highest point of the cam lobe while adjustment is being made. Recheck point gap after tightening the adjusting and stationary screw.
 - (3) Coat the cam with a thin film of cam lubricant and saturate the felt wick in the top of the cam with medium engine oil.
 - (4) Using a spring scale hooked onto the breaker arm near the contact, adjust breaker arm spring tension from 17 to 22 ounces. Observe reading just as points separate.
- b. Spark Plug Gap. Clean the spark plugs thoroughly, using an abrasive type cleaner. If the porcelain is badly glazed or blistered, the spark plugs should be replaced.

NOTE

Before adjusting spark plug gap, file the center electrode flat. In adjusting, never bend the center electrode which extends through the porcelain center. Always make adjustment by bending the ground or side electrode.

Use a round feeler gage and adjust each spark plug gap for .030-inch.

c. Ignition Timing. Using timing light adapter, timing light and tachometer, adjust ignitor timing as follows:

- (1) Loosen ignitor adjusting nut (2 fig 2-31).
- (2) Install timing light adapter on number 1 spark plug and connect spark plug cable to adapter.
- (3) Connect timing light leads in accordance with timing light manufacturer s recommendation.

WARNING

Hazardous voltage is present at diagnostic test point under plug on ignitor cover. Do not remove access plug or connect a tachometer to this point. The voltage present at this point will damage a tachometer.

- (4) Connect tachometer leads in accordance with tachometer manufacturer s recommendations.

WARNING

Keep hands and clothing clear of fan belts and pulleys to avoid personal injury when engine is running.

- (5) Start engine and allow to obtain normal operating temperature.
- (6) Adjust idle speed to 650 rpm.

NOTE

In the following Step, rotate ignitor clockwise to advance or counter-clockwise to retard spark.

- (7) While observing timing line on timing chain cover pointer with timing light, ignitor shall be rotated until timing line appears alined with 5 degree advance mark on timing scale on crankshaft vibration damper. Refer to figure 2-30.

NOTE

The timing scale on crankcase front cover is graduated in 1 degree increments.

(8) When timing is adjusted to 5 degrees BTC advance, tighten ignitor adjusting nut. Refer to figure 2-31.

(9) Recheck timing to insure that it was not disturbed when nut was tightened.

(10) While observing timing line with timing light, increase engine speed. Timing line should appear to move in advance direction indicating proper operation of centrifugal advance mechanism.

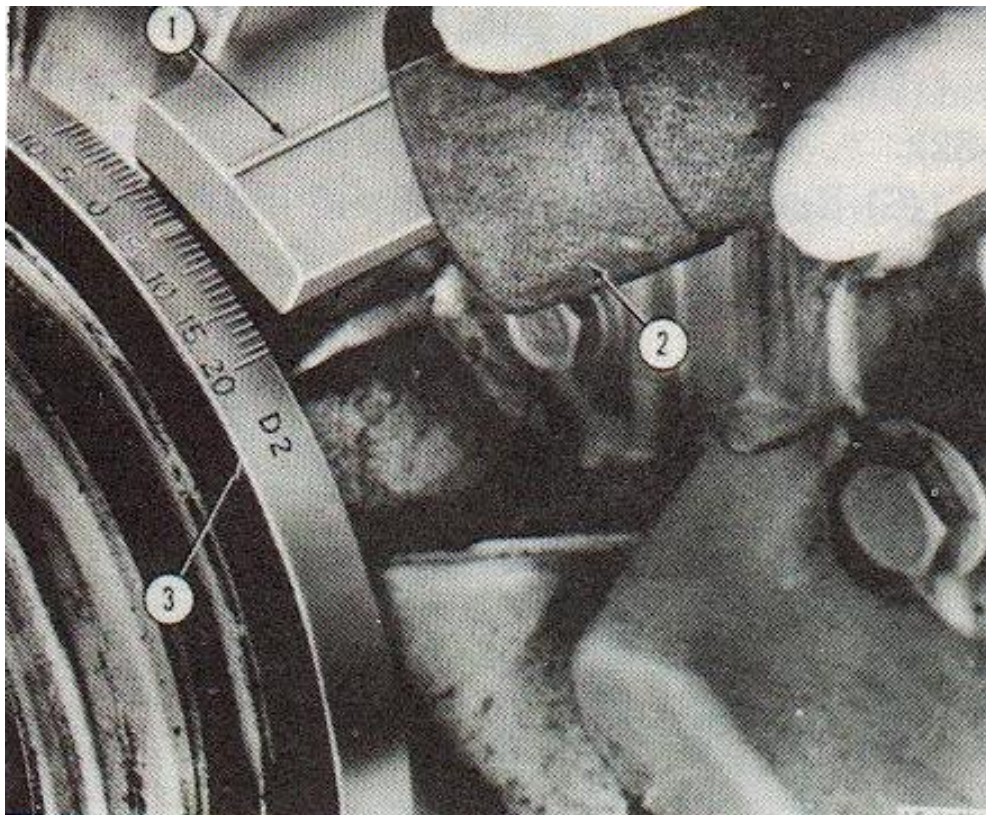

Figure 2-30. Timing engine with light

1 Timing pointer

2 Timing light

3 Vibration damper

(11) Shut off engine.

(12) Disconnect tachometer, timing light and spark plug adapter.

(13) Connect cable to number 1 spark plug and tighten nut.

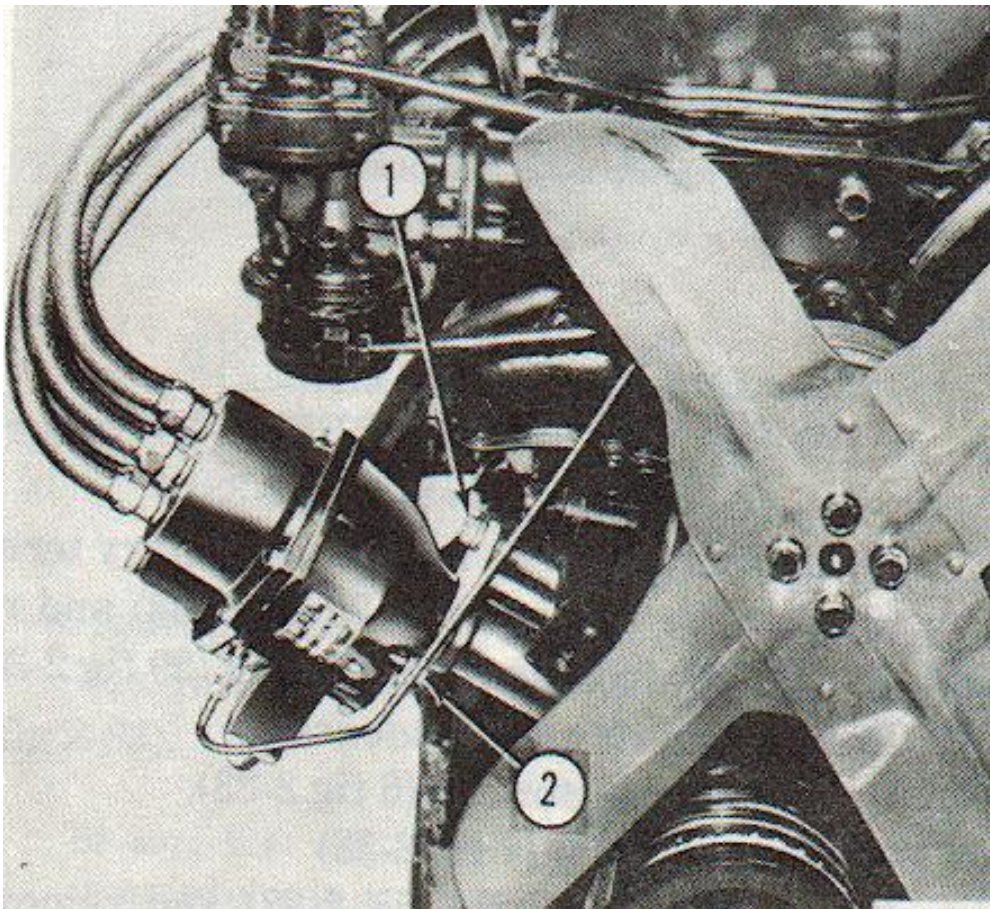

Figure 2-31. ignitor adjusting nut.

- 1 Adjusting nut
- 2 Mounting bolt

2-52. Removal.

a. Ignitor.

- (1) Disconnect battery ground cable from battery negative terminal.
- (2) Disconnect two vacuum ventilation lines (4 fig 2-32).
- (3) Disconnect low tension lead from ignitor housing.
- (4) Remove spark plug leads (1 fig 2-32).
- (5) Remove cap screw and lock washer (2 fig 2-32).
- (6) Remove ignitor from timing chain cover by pulling straight out.

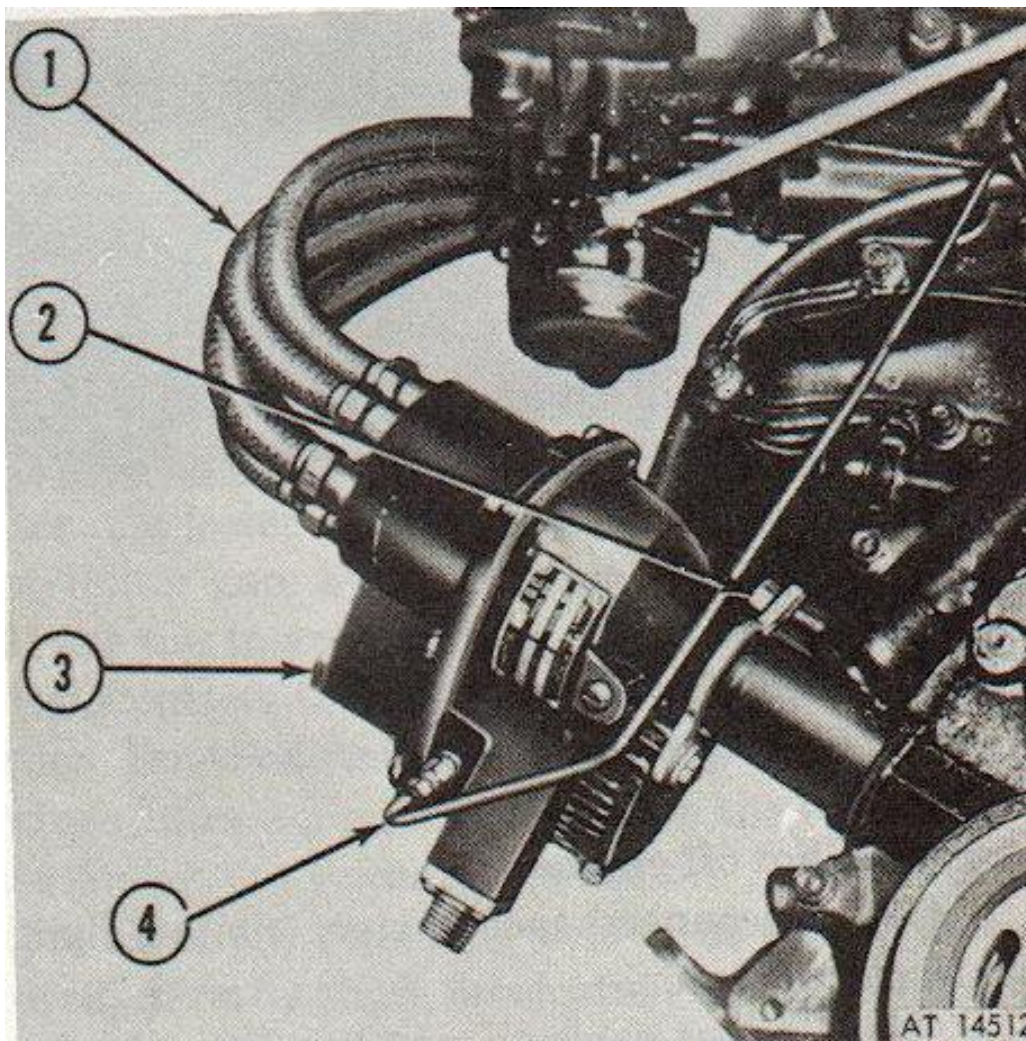

Figure 2-32. Removing ignitor.

- 1 Spark plug leads
- 2 Cap screw and lock washer
- 3 Coil primary terminal access hole
- 4 Ventilation outlet line

b. Ignitor Coil.

- (1) Remove six screws (58 fig 2-33) and remove cover (3 fig 2-33) and gasket (4 fig 2-33).
- (2) Disconnect leads from coil primary terminals.
- (3) Remove two screws (20 fig 2-33) and remove coil (21 fig 2-33) from ignitor housing (29 fig 2-33).

c. Breaker points and Condenser.

- (1) Remove ignitor cap (6 fig 2-33).

- (2) Remove rotor (7 fig 2-33)
- (3) Loosen screw (54 fig 2-33) and remove condenser lead.
- (4) Remove screw (51 fig 2-33) and remove condenser (52 fig 2-33).
- (5) Remove screw (9 fig 2-33) and remove breaker point base and arm (55, 56 fig 2-33).

d. Spark Plugs.

- (1) Disconnect spark plug terminal nuts from spark plugs, using cable wrench FSN 5120-168-2283. (Fig 2-34)
- (2) Remove all dirt from around spark plugs.
- (3) Remove spark plugs by using a 13/16-inch deep well socket and turning counter-clockwise. Discard spark plug gaskets.

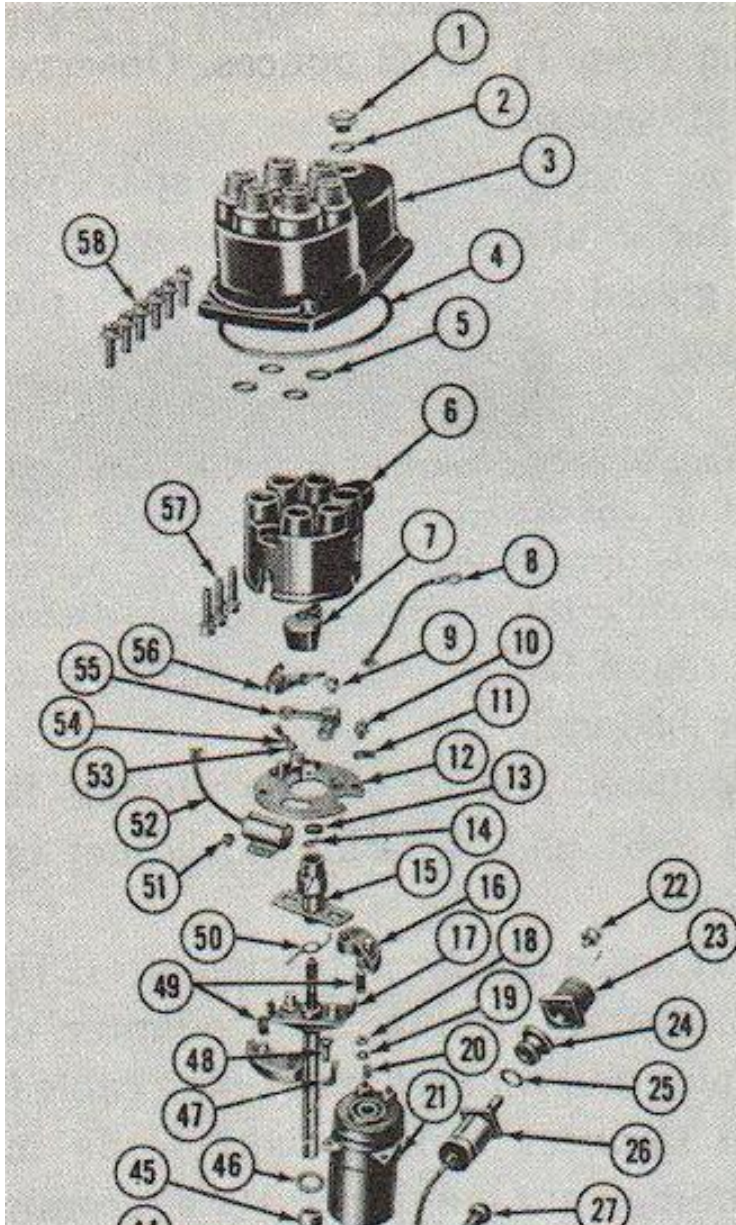

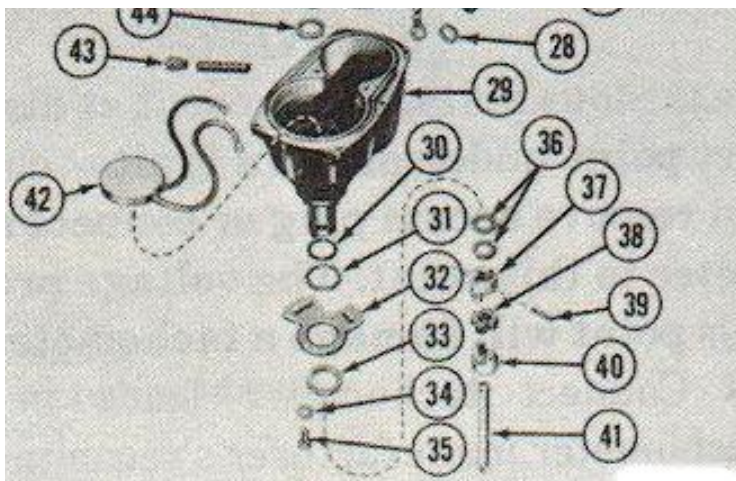

Figure 2-33. Ignitor-exploded view.

1 Access cover plug	11 Plate	21 Ignition coil	31 Gasket	41 Drive shaft	51 Screw
2 O-ring	12 Breaker plate	22 Screw	32 Mounting plate	42 Coil ballast	52 Condenser
3 Cover	13 Felt wick	23 Housing	33 Gasket	43 Plug screw	53 Clip
4 O-ring gasket	14 Snap ring	24 Seal	34 Lock washer	44 Washer	54 Screw
5 Terminal washer	15 Cam	25 Seal ring	35 Cap screw	45 Collar	55 Breaker point base
6 Cap	16 Governor weight	26 Capacitor	36 Spring washer	46 Washer	56 Breaker point arm
7 Rotor	17 Shaft	27 Plug	37 Coupling	47 Clamp	57 Cap screw
8 Cable	18 Terminal nut	28 Gasket	38 Spider coupler	48 Screw	58 Cover screw
9 Screw	19 Terminal washer	29 Housing	39 Roll pin	49 Coil spring	
10 Plate screw	20 Screw	30 O-ring	40 Coupling	50 Anti-rattle	

e. Spark Plug Cables.

NOTE

If cables are not identified with respect to proper cylinder, identify prior to removal.

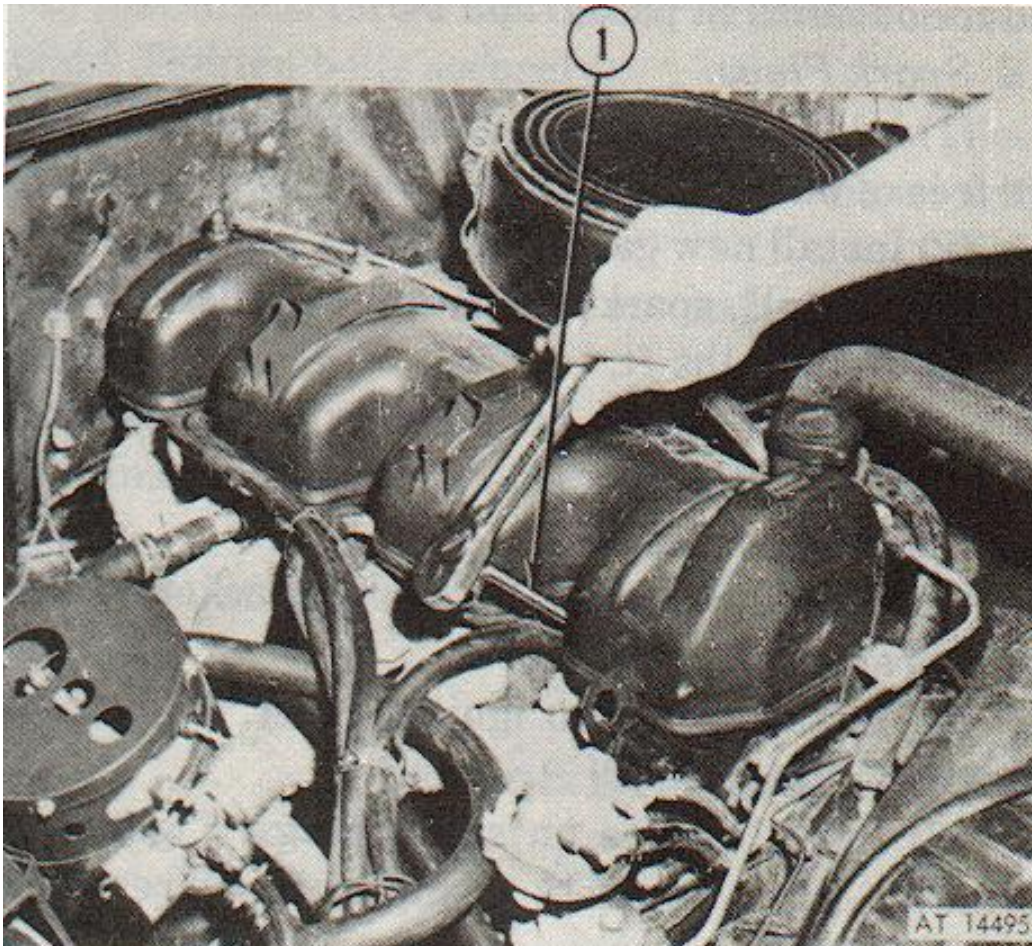

Figure 2-34. Spark plug and cable removal.

- (1) Disconnect cable terminal nuts from distributor cover.
- (2) Disconnect cable terminal nuts from spark plugs.
- (3) Remove spark plug cable bracket attaching bolts and disengage cables from bracket.

2-53. Cleaning and Inspection.

- a. Refer to paragraph 2-51b for spark plug cleaning and gap adjustment.
- b. Clean ignitor cover and cap of all dirt, grease and corrosion. Carefully inspect cover and cap for evidence of carbon tracking.
- c. Inspect rotor for cracks, loose contact strip, or if strip shows evidence of excessive burning or arcing.
- d. Clean rotor spring contact button so that it will make a good contact with the carbon contact in the center of the cap. Check height of spring to be sure it touches carbon contact of the cap when the cap is installed.
- e. Inspect coil carefully for evidence of cracks. Clean terminals of all corrosion.
- f. Inspect spark plug cables for fraying and deterioration. Check terminal nut threads for evidence of stripping or cross threading.
- g. Inspect breaker point contacts; if contacts are rough, pitted or burned, discard and install new.

2-54. Installation.

a. Breaker Points and Condenser.

- (1) Position breaker point base and arm (55 and 56 fig 2-33) and install screw (9 fig 2-33).
- (2) Adjust breaker point contact gap to .020-inch, + or - .002-inch.
- (3) Adjust breaker arm spring tension from 17 to 22 ounces. Refer to paragraph 2-51.
- (4) Install condenser (52 fig 2-33) on breaker plate and secure with screw (51 fig 2-33).
- (5) Attach condenser lead to terminal screw (54 fig 2-33) and tighten.
- (6) Install rotor.
- (7) Install ignitor cap.

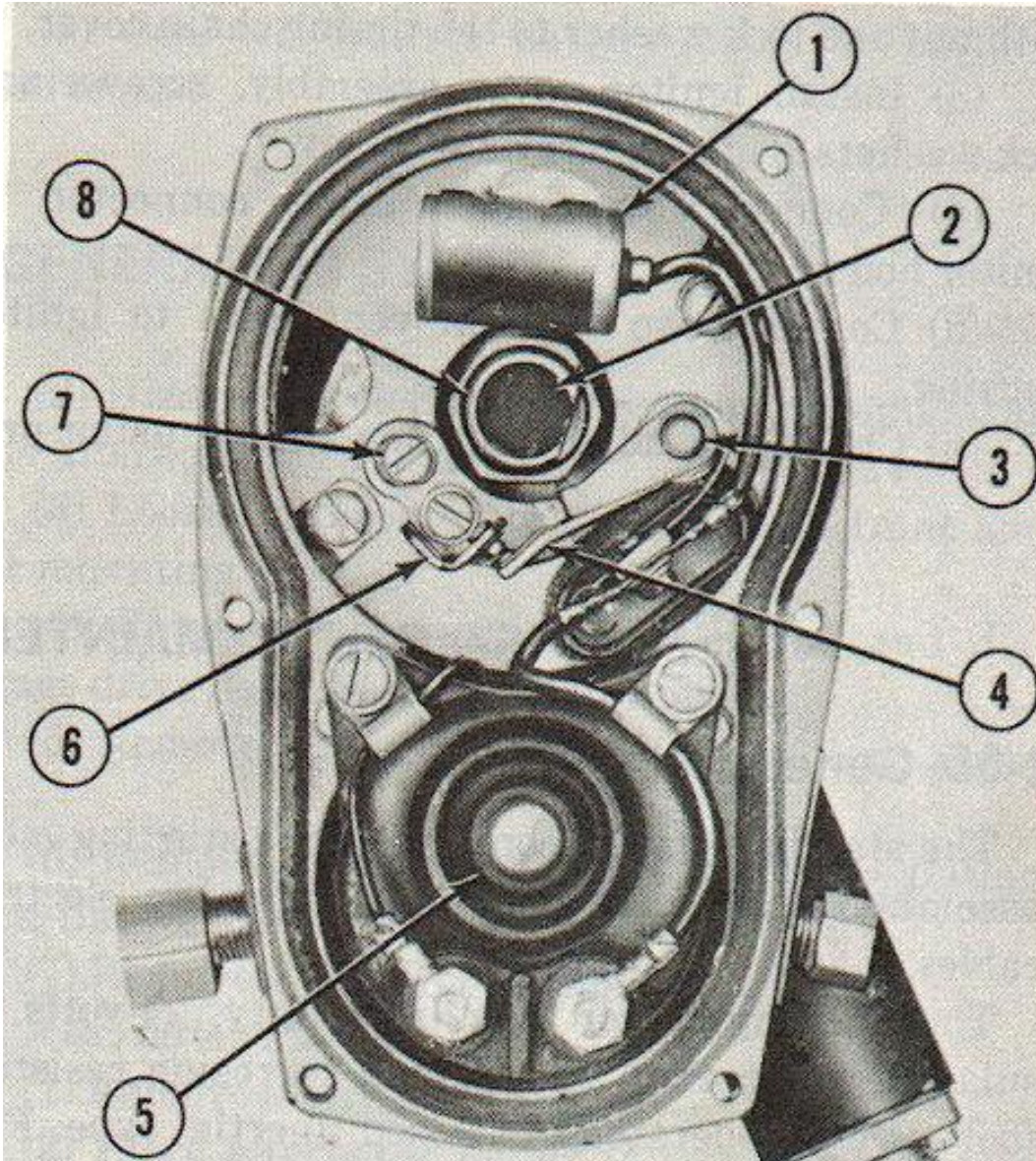



Figure 2-35. Ignitor points.

- 1 Condenser
- 2 Lubrication wick
- 3 Breaker arm pivot
- 4 Breaker points
- 5 Coil
- 6 Stationary contact
- 7 Adjusting screw
- 8 Breaker cam

b. Ignitor Coil.

- (1) Install ignitor coil into ignitor housing (21 fig 2-33).

NOTE

Be sure that coil positive terminal is positioned under threaded plug in ignitor cover.

- (2) Install screws (20 fig 2-33) and tighten securely.
- (3) Attach wires to coil primary terminals and tighten nuts.
- (4) Install ignitor cover (3 fig 2-33) and gasket (4 fig 2-33).
- (5) Install six lock washers and screws (58 fig 2-33) and tighten securely.
- (6) Connect battery cable to battery negative terminal.

c. Ignitor. If a new ignitor is being installed, or if camshaft has been rotated with ignitor removed, rotate crankshaft until timing line on timing case cover is aimed with 0 mark on scale on vibration damper and engine is in the number 1 firing position.

- (1) Look down the ignitor shaft hole with a light and observe the position of the slot in the end of the oil pump shaft. It should be at the 3 and 9 o'clock position with the narrow side of the shaft on top.
- (2) Rotate the ignitor shaft so the tongue at the end of the shaft will engage the groove in the end of the oil pump shaft. Position the ignitor and secure with nut and lock washer to the timing chain cover.
- (3) Install ignitor cover assembly, screws and lock washers. Tighten screws securely.
- (4) Connect low-tension cable connector to ignitor housing.
- (5) Connect two vacuum vent lines to ignitor housing.
- (6) Check and adjust ignition timing using procedure outlined in paragraph 2-51c.

d. Spark Plugs.

- (1) Insure that the perimeter of spark plug holes are free of dirt and grease.
- (2) Install new gaskets on spark plugs.
- (3) Install spark plugs in cylinder head and tighten 26 to 30 lbs-ft.
- (4) Install spark plug cables and tighten terminal nuts securely.

e. Spark Plug Cables.

- (1) Position cables in cable brackets. Tighten cable bracket clamps.
- (2) Install cables in ignitor cover. Tighten cable terminal nuts securely.

- (3) Install cables on spark plugs. Tighten cable terminal nuts securely using cable wrench FSN 5120-168-2283.

Section XV. MAINTENANCE OF STARTING SYSTEM

2-55. General.

The starting system consists of the starting motor assembly, starter switch and connecting electrical cables.

The starting motor is a light duty, 24-volts, insulated, waterproof, fungus and corrosion resistant, foot switch operated, enclosed inertia type Folo Thru Drive, with four brushes retained in four brush holders, The operation of the starting motor is controlled by the starter switch. The starter consists of a frame, field coil, armature and brushes. The starting switch electrically closes the circuit between the battery and the starting motor. The starting switch is located on the hump of the floor board, to the right of the accelerator pedal and ahead of the gear shifter lever. No repairs or adjustments can be made to the starter switch. If trouble develops in the starter switch, it must be replaced.

2-56. Maintenance and Adjustment.

Extra large grease reservoirs contain an adequate supply of lubricant. No periodic maintenance except external cleaning is required.

2-57. Removal.

a. Starter Motor.

- (1) Disconnect battery cable from battery negative terminal.
- (2) Disconnect starter switch-to-starting motor lead cable.
- (3) Remove two bolts and lock washers.
- (4) Remove starter motor assembly from flywheel housing.
- (5) Remove starter motor gasket and discard.

b. Starter Switch.

- (1) Disconnect battery cable from battery negative terminal.
- (2) Remove four screws which secure starter switch and mounting plate to floor panel.
- (3) Remove two starter switch retaining bolts and washers which secure switch to mounting plate.
- (4) Pull switch through floor panel access hole.
- (5) Disconnect cables from starter switch and remove switch assembly.

c. Starter Cable.

- (1) Disconnect battery cable from battery positive terminal and remove cable.
- (2) Disconnect starter switch-to-starter motor lead cable and remove cable.

2-58. Cleaning and Inspection.

CAUTION

Do not clean starter motor in any degreasjug tank or with grease dissolving solution as this will tend to dissolve lubricants in the starter motor clutch mechanism.

- a. Clean exterior of starter motor assembly with clean dry cloth.
- b. Inspect exterior of case and mounting tabs for cracks.
- c. Inspect electrical connectors for corrosion and looseness.
- d. Clean and lightly oil threads of all attaching bolts and nuts.

2-59. Installation.

a. Starter Switch.

- (1) Connect cables to starter switch terminals.
- (2) Install starter switch to starter switch mounting plate. Tighten bolts securely.
- (3) Insert switch through access hole in floor panel and secure mounting plate to floor panel with four screws.
- (4) Install battery cable on battery negative terminal.

b. Starter Motor.

- (1) Install gasket against starter motor drive end-frame.
- (2) Position gasket and starter motor assembly on flywheel housing and install bolts and lock washers. Tighten bolts to 40-50 lbs-ft.
- (3) Connect starter switch-to-starter motor lead cable,
- (4) Connect battery ground cable to battery negative terminal and check operation of the unit.

c. Starter Cable.

- (1) Connect starter switch-to-starter motor lead cable.
- (2) Connect positive battery cable to battery positive post.

Section XVI. MAINTENANCE OF GENERATING SYSTEM

2-60. General.

The 24-volt generating system includes the alternator/regulator, (fig 2-36) batteries and the necessary connecting cables and wiring. The generating system is a self-rectifying unit with a built-in voltage regulator. All current carrying conductors are stationary. The only moveable part is the rotor. The system is completely sealed against the entrance of water, to provide for efficient performance during fording operation.

2-61. Maintenance and Adjustment.

A fan located on the end of the alternator/regulator provides airflow for cooling. Extra large grease reservoirs contain an adequate supply of lubricant. No periodic maintenance beyond external cleaning is required,

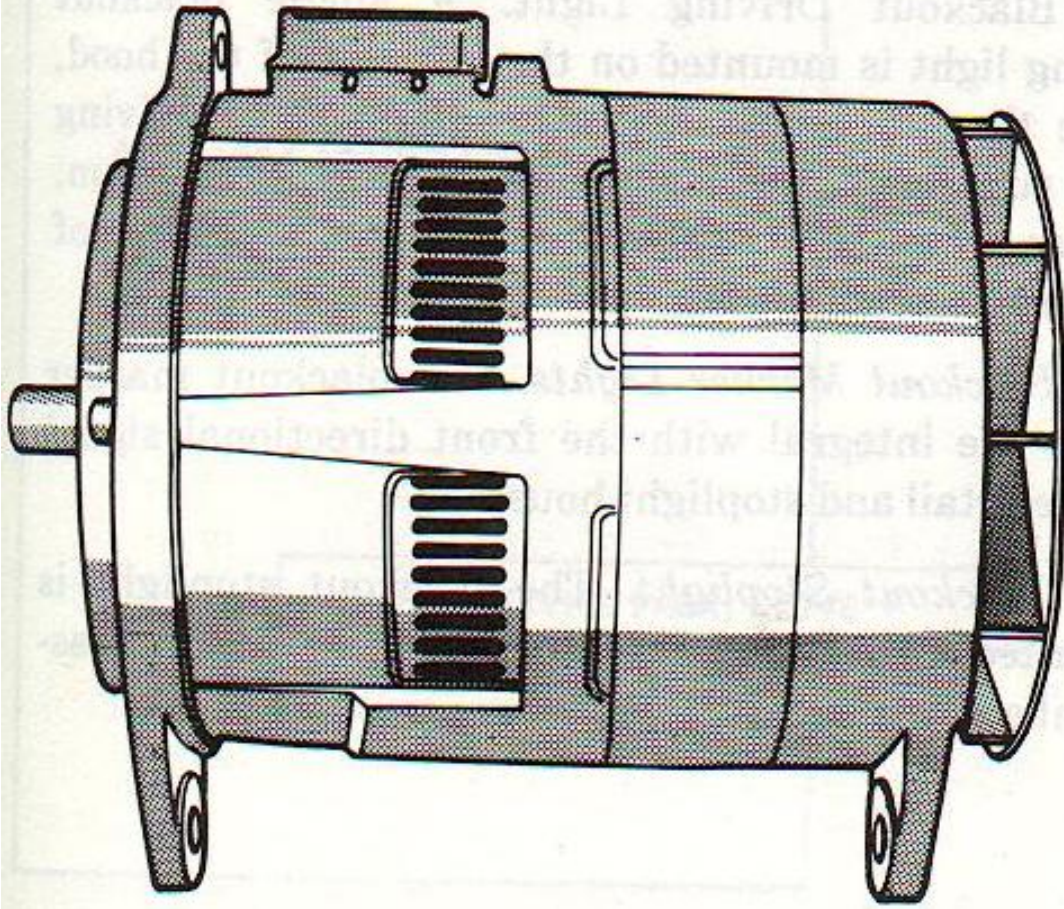

Figure 2-36. Alternator.

2-62. Removal.

a. Alternator/Regulator

- (1) Disconnect battery cable at battery negative terminal.
- (2) Disconnect electrical wires and ground strap from alternator terminals.
- (3) Loosen alternator brace bolts and front and rear mounting bolts.
- (4) Rotate alternator toward engine and disengage drive belts from alternator pulley.
- (5) Remove alternator brace bolt and lock washer.
- (6) Remove alternator front and rear mounting bolts, flat washers and nuts.
- (7) Remove alternator assembly,

b. Alternator Pulley.

- (1) Remove alternator (a) above.
- (2) Place alternator pulley in copper jawed vise and hold securely. **DO NOT WEDGE FAN WHEN REMOVING PULLEY.** Using a 15/16-inch wrench on the pulley nut, remove pulley attaching nut and washer.

(3) Pull pulley off of alternator shaft.

c. Alternator Mounting Bracket.

(1) Remove alternator assembly as outlined in paragraph (a) above.

(2) Remove two bolts, lock washers and flat washers which secure bracket to left side of cylinder block.

(3) Remove alternator mounting bracket assembly.

d. Alternator Brace.

(1) Remove bolt and washers which secure brace to alternator and brace to intake manifold.

(2) Rotate alternator toward engine.

(3) Remove two bolts, lock washers and flat washers which secure brace to timing chain cover.

(4) Remove alternator brace,

2-63. Cleaning and Inspection.

a. Clean exterior of alternator case of dirt and grease.

b. Inspect alternator mountings for cracks.

c. Inspect electrical terminals for looseness and corrosion.

d. Clean and lightly oil threads of all attaching bolts and nuts.

2-64. Installation.

a. Alternator Mounting Bracket.

(1) Position alternator mounting bracket on the left side of cylinder block.

(2) Install two mounting bolts and washers into cylinder block and tighten to 45 lbs-ft.

b. Alternator Pulley.

(1) Position pulley on alternator shaft.

(2) Install attaching nut and washer and tighten to 50 lbs-ft.

(3) Install alternator (c) below and adjust tension in accordance with procedure outlined in paragraph 2-46j.

c. Alternator.

(1) Position alternator assembly on mounting bracket.

(2) Install the front and rear bolts, flat washers and nuts which secure alternator to its mounting. Tighten to a firm fit.

(3) Install bolts and lock washers which secure the alternator brace and intake manifold brace.

(4) Install drive belts on alternator pulley. Adjust tension on belts in accordance with procedure outlined in paragraph 2-46j.

(5) Tighten alternator brace bolt to 15-20 lbs-ft.

(6) Tighten front and rear mounting bolts to 25-30 lbs-ft.

(7) Install electrical wires and ground strap to their respective terminals.

(8) Connect battery negative cable to battery terminal.

d. Alternator Brace.

(1) Position alternator brace on timing chain cover, install two bolts and lock washers. Do not tighten.

(2) Install intake manifold brace to alternator brace bolt, lock washer and nut. Do not tighten.

(3) Install bolt and washer through brace into alternator housing.

(4) Tighten bolts which secure brace to timing chain cover to 20-30 lbs-ft.

(5) Adjust drive belt tension in accordance with procedure outlined in paragraph 2-46j.

(6) Tighten alternator housing brace bolt to 15-20 lbs-ft. Tighten intake manifold brace to alternator brace bolt and nut to 12-15 lbs-ft.

Section XVII. MAINTENANCE OF BATTERIES AND LIGHTING SYSTEM

2-65. General.

The lighting system consists of all lights, light switches, connecting wires and cables. All exterior lights except the spotlight are controlled by the light switch on the instrument panel (fig 2-37). Interior lights and spotlight in the ambulance truck are controlled by switches in the light housings. Circuit breakers located in the light switch protect against overload. All electrical cables are identified by numbered tags near the end of each cable.

- a. Batteries. A 24-volt primary circuit is provided by the two 12-volt, lead-acid type storage batteries connected in series (fig 2-38). The batteries incorporate side terminal screw-on connections. As a field expedient, any 45 ampere/hour battery having the same external dimensions may be used with cable terminal adapters. Refer to figure 2-39 for Ambulance battery compartment identification.
- b. Service Headlights. The sealed beam type service headlights are mounted in the front end sheet metal behind the brush guard. High or low beam may be selected with a foot operated switch.
- c. Blackout Driving Light. A single blackout driving light is mounted on the left side of the hood, above the left front service headlight. This driving light supplies a diffused, low-intensity light beam, for use when the tactical situation prohibits use of the service headlights.
- d. Blackout Marker Lights. The blackout marker lights are integral with the front directional signal and rear tail and stoplight housings.
- e. Blackout Stoplight. The blackout stoplight is mounted on the right side of the rear frame crossmember.

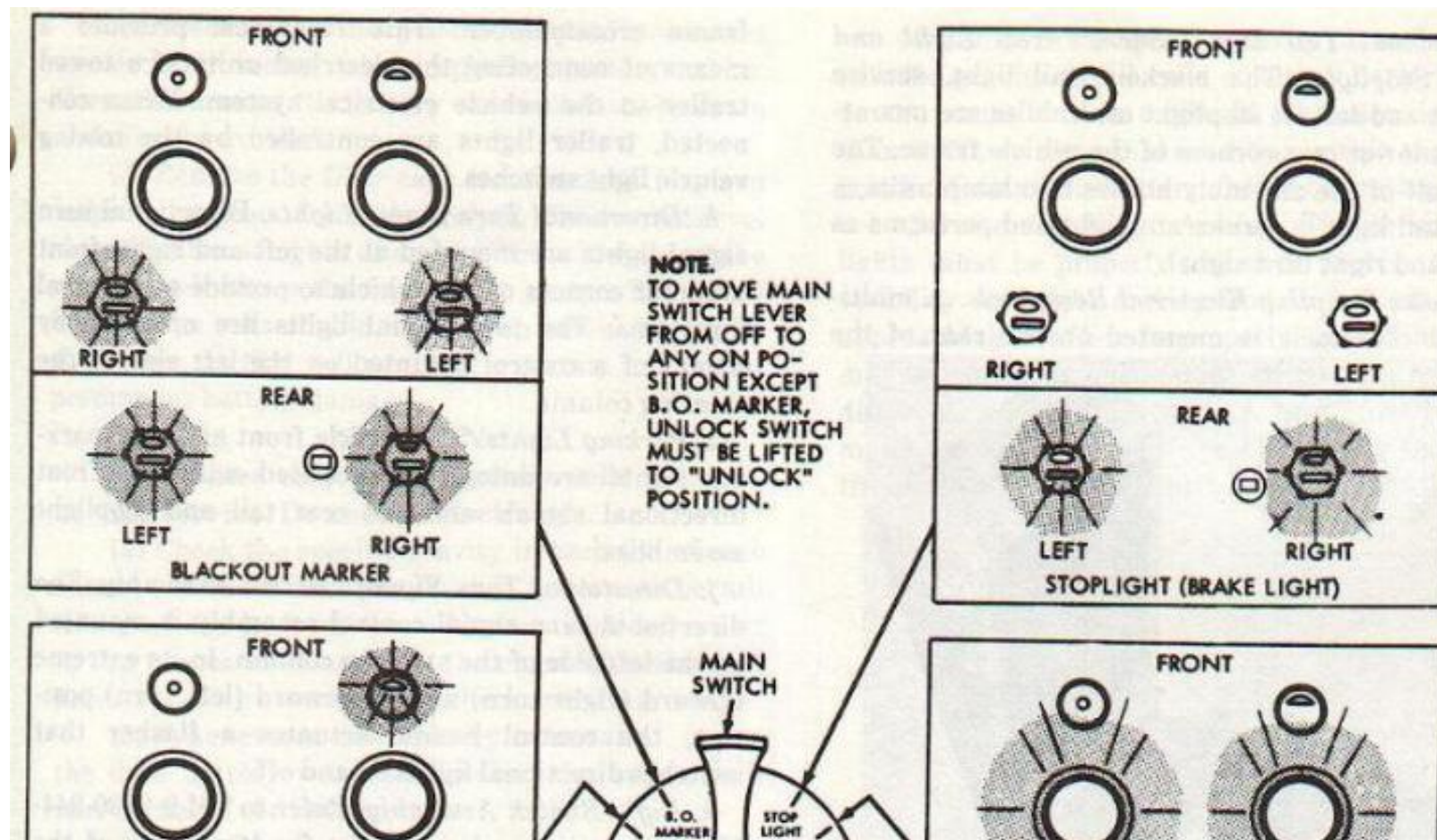

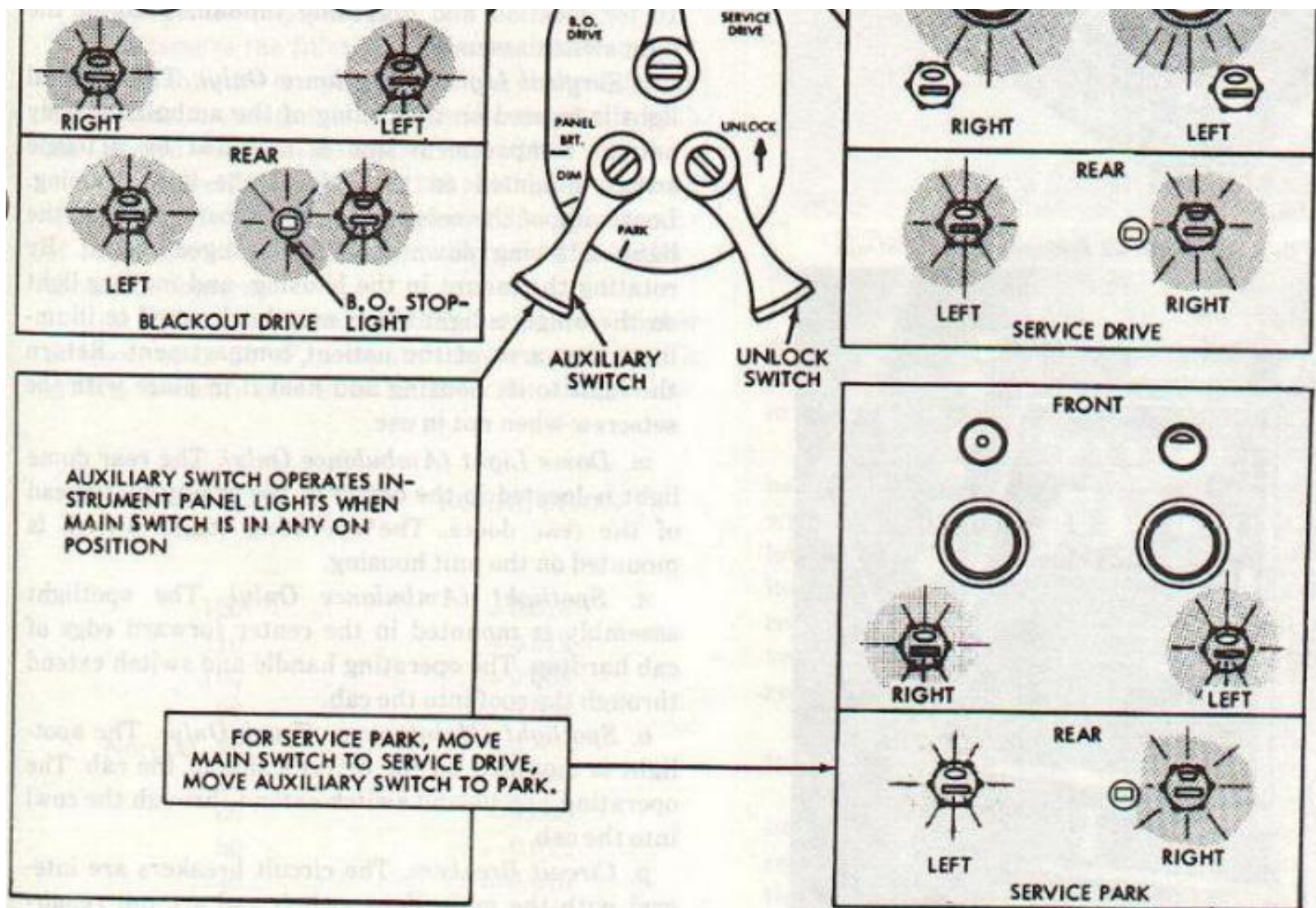

FIGURE 2-37. Main Light Switch And Vehicle Light Chart

f. Blackout Tail Light. Service Tail Light and Service Stoplight. The blackout tail light, service tail light and service stoplight assemblies are mounted in the lower rear corners of the vehicle frame. The upper half of the assembly houses two lamp units, a service tail light, a service stoplight and performs as the left and right turn signal.

g. Trailer Coupling Electrical Receptacle. A multi-terminal receptacle is mounted on the rear of the frame crossmember. This receptacle provides a means of connecting the electrical units of a towed trailer to the vehicle electrical system. When connected, trailer lights are controlled by the towing vehicle light switches.

h. Directional Turn. Signal Lights. Directional turn signal lights are mounted at the left and right, front and rear corners of the vehicle to provide turn signal directions. The turn signal lights are operated by means of a control mounted on the left side of the steering column.

i. Parking Lights. The vehicle front and rear parking lights are integrally mounted with the front directional signals and the rear tail and stoplight assemblies.

- j. Directional Turn Signal Control Assembly. The directional turn signal control assembly is mounted on the left side of the steering column. In its extreme upward (right turn) and downward (left turn) position, the control handle actuates a flasher that switches directional lights on and off.
- k. Light Switch Assembly. Refer to TM 9-2320-244-10 for location and operating fundamentals of the light switch assembly.
- l. Surgical Light (Ambulance Only). The surgical light is located on the ceiling of the ambulance body patient compartment and is operated by a toggle switch mounted on the side of the light housing. Loosening of the setscrew on the housing enables the light to swing down on a ball hinged mount. By rotating the mount in the housing, and moving light on the hinge, a light beam may be directed to illuminate any area of the patient compartment. Return the light to its housing and hold it in place with the setscrew when not in use.
- m. Dome Light (Ambulance Only). The rear dome light is located in the center of the ceiling just ahead of the rear doors. The operating toggle switch is mounted on the unit housing.
- n. Spotlight (Ambulance Only). The spotlight assembly is mounted in the center forward edge of cab hardtop. The operating handle and switch extend through the roof into the cab.
- o. Spotlight (Maintenance Truck Only). The spotlight is mounted on the driver's side of the cab. The operating handle and switch extend through the cowl into the cab.
- p. Circuit Breakers. The circuit breakers are integral with the main light switch and are not repairable. Should circuit breakers fail to function properly, the main light switch must be replaced.



FIGURE 2-38. Batteries, holddown, bolts and straps.

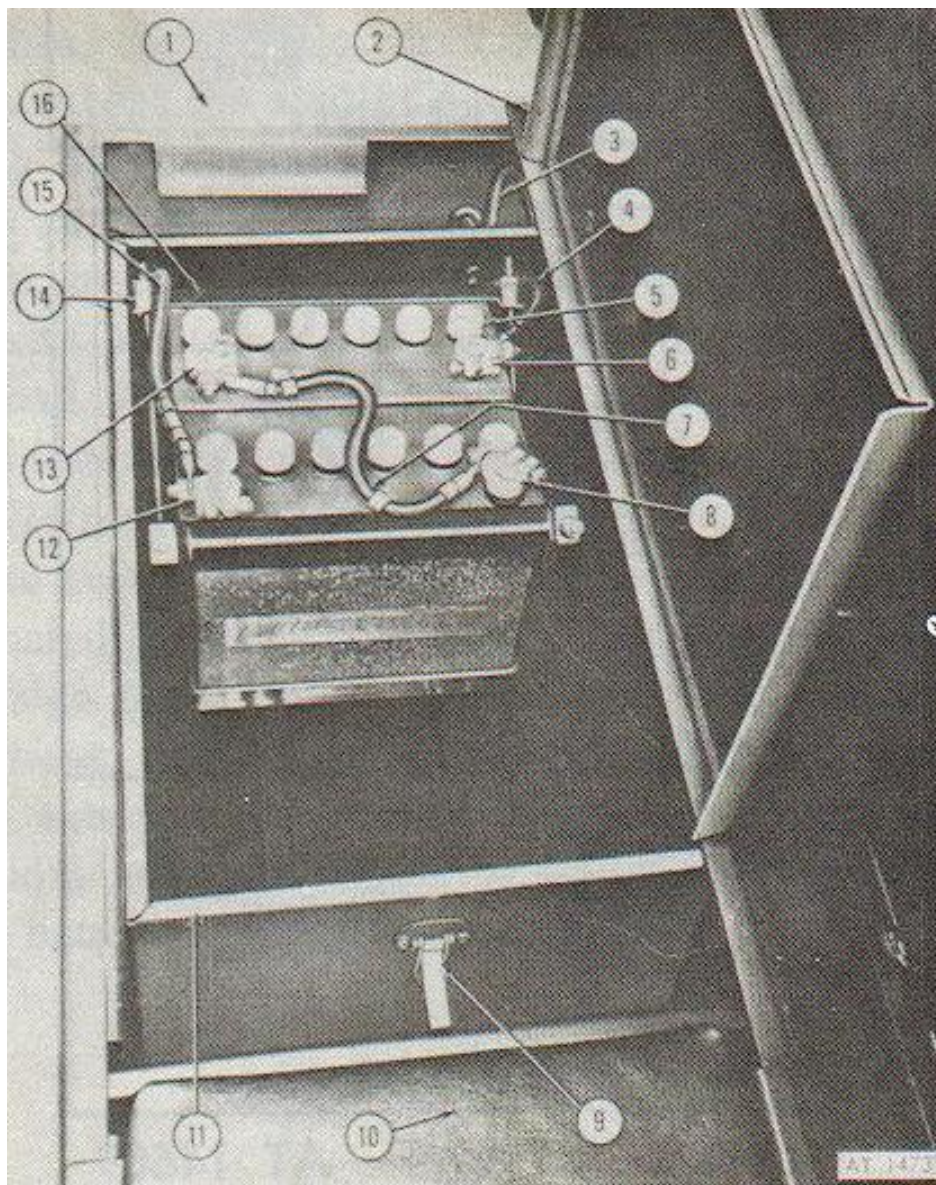

Figure 2-39 Battery compartment (Ambulance).

1 Bulkhead	9 Cover clamp
2 Battery box cover	10 Seat cushion
3 Body circuits feed cable	11 Battery box
4 Battery positive cable	12 Negative post
5 Filler cap	13 Negative post clamp

6 Positive post	14 J-bolt spacer and nut
7 Series cable	15 Negative cable (ground)
8 Positive post clamp	16 Battery holddown clamp

2-66. Maintenance and Adjustment.

a. Batteries,

(1) Clean batteries and battery cable terminals to remove all corrosion and dirt.

(2) Insure that the plastic terminal protectors are securely seated when replacing battery cables. Corrosion around the battery can cause battery drain and must be avoided.

(3) Remove the filler caps from each battery and inspect the level of the electrolyte. The correct level should be three-eighths of an inch below the top of the cell, or well above the tops of the plates. The liquid level in the cells should never drop below the top of the plates, as this will result in a certain amount of permanent battery damage.

CAUTION

Add water only to the battery cells during service. Do not add electrolyte.

(4) Check the specific gravity in each cell of each battery. If the electrolyte level is too low to permit filling of the hydrometer, add clean distilled water to the proper level and run the engine for about 30 minutes before attempting to check specific gravity.

(5) Whenever a new battery is installed, stamp the date battery was energized on the upper right rear corner of the battery case.

b. Specific Gravity Check.

(1) Remove the filler caps from each battery cell. Test and note the temperature of the electrolyte and use a hydrometer to test the specific gravity in each cell. Record observations on DA Form 2404.

(2) A specific gravity of 1.280 at 80° F in each cell indicates a fully charged battery. Specific gravity of less than 1.225 is unsatisfactory and the battery should be charged.

(3) If the temperature of the electrolyte is higher or lower than 80° F, compute the corrected specific gravity in accordance with the correction chart below.

TEMPERATURE in Farenheit	CORRECTION
120	+.016
110	+.012
100	+.008
90	+.004
80	0
70	-.004
60	-.008
50	-.012

40	-.016
30	-.020
20	-.024
10	-.028
0	-.032
-10	-.036
-20	-.040

(4) Compare the specific gravity for each cell. The specific gravity in all cells of either battery should be the same, within 0.050. If variation is greater than 0.050, an abnormal condition within the battery is indicated and the battery should be replaced.

c. Service Headlight Aiming. The service headlights must be properly aimed to provide adequate visibility for night driving and to prevent glare to approaching traffic. Improperly aimed headlights may be caused by unequal inflation of the front tires, difference in tread of the tires, bent front end sheet metal, or damaged front springs. Check and correct these items before attempting to adjust headlights.

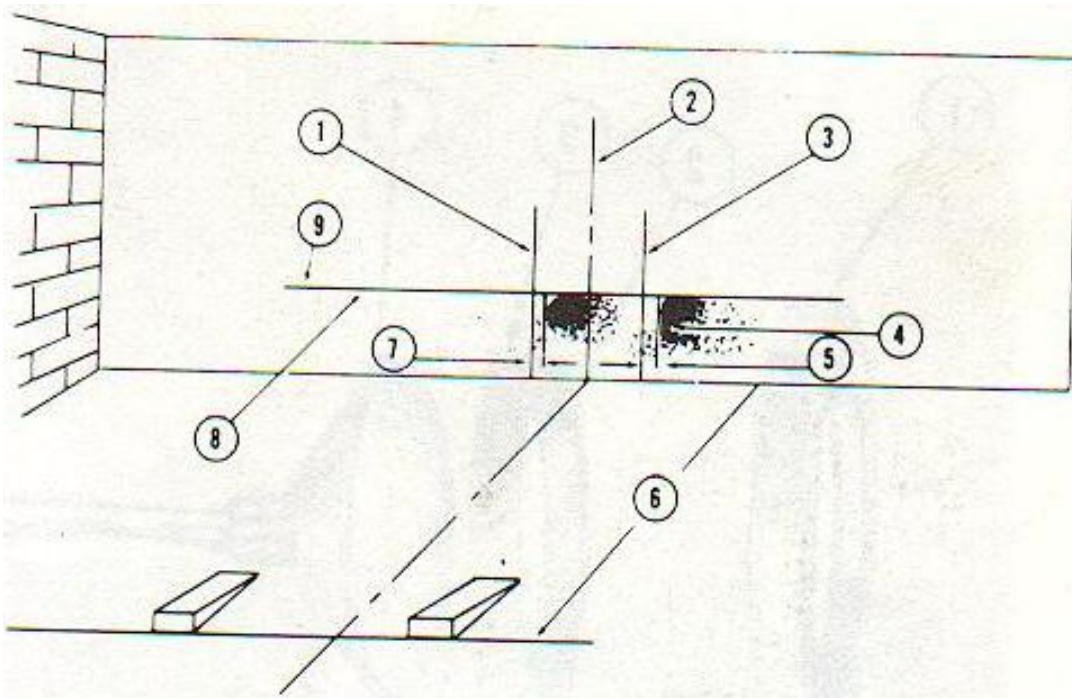

Figure 2-40. Headlight aiming chart.

- (1) Position the vehicle on a level floor with no load in vehicle.
- (2) Locate a screen at right angles to the vehicle exactly 25 feet ahead of the headlights. Move the screen so that the centerline of the screen is directly in line with the centerline of the vehicle,
- (3) Measure the distance from the center of the headlights to the floor. Compare this measurement with the horizontal line (9) on the screen. Raise or lower the horizontal line on the screen until it is 3 inches below the measured height of the headlight centers. Line (1) and (3) must be aimed with the vertical

center lines of the left and right headlights, respectively.

(4) Turn the headlights on and operate the selector switch to high beam.

(5) If either headlight pattern differs from figure 2-40, loosen or tighten the adjusting screws as required to produce the correct pattern. Adjust the remaining headlight, if necessary, in the same manner.

2-67. Removal.

a. Batteries.

(1) Disconnect negative and positive battery cables from battery terminals.

(2) Remove four nuts, washers and hold down bolts which secure battery top frame and remove frame assembly.

(3) Pick up and remove batteries from battery tray.

WARNING

Insure that battery cell caps are secure on batteries to prevent electrolyte leakage on personnel.

b. Battery Tray.

(1) Remove batteries as outlined in paragraph above.

(2) Remove six bolts and lock washers which secure battery tray to floor panel and remove battery tray.

c. Service Headlight Sealed Beam Unit. (Fig 2-41)

(1) Remove three headlamp door retaining screws and remove door.

(2) Disengage spring from sealed beam retaining ring.

Note

During sealed beam removal, do not disturb adjusting screws.

(3) Turn headlamp unit to disengage assembly from headlamp adjusting screws and remove retaining ring.

(4) Pull sealed beam unit out of housing and disconnect wiring harness connector.

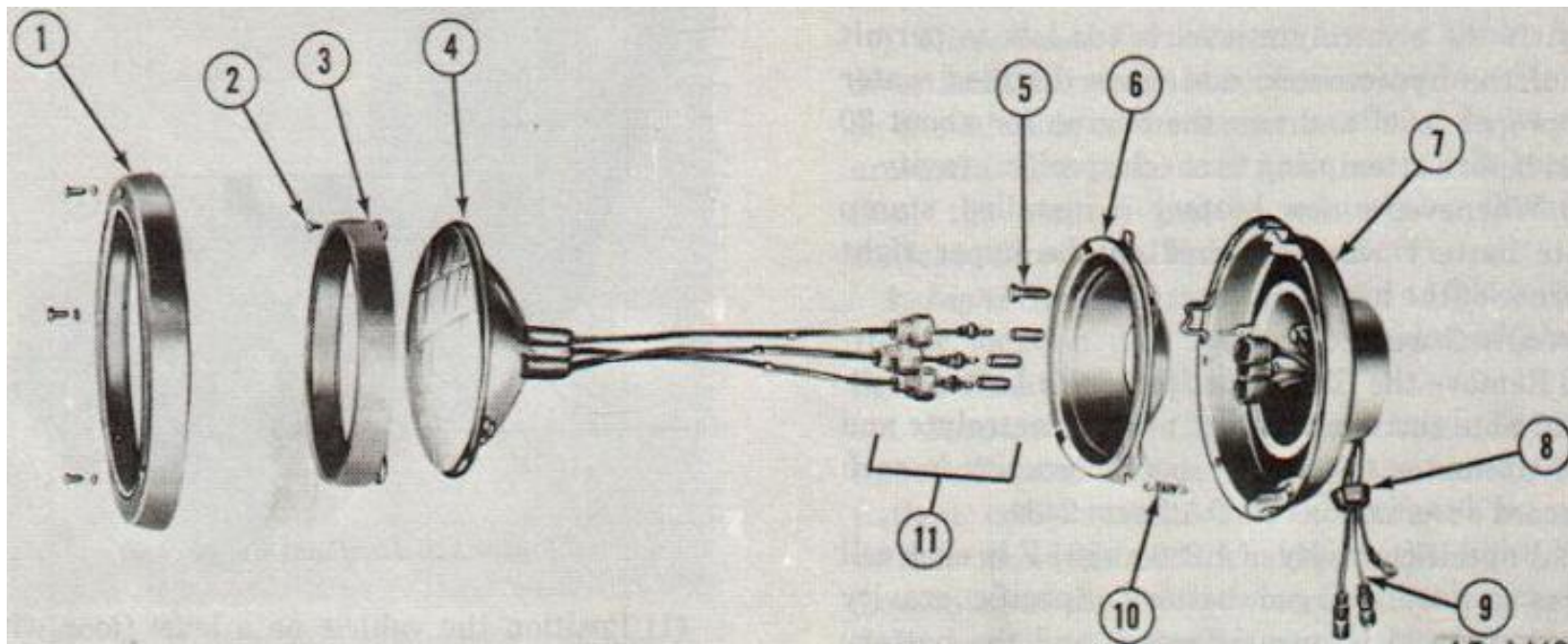

Figure 2-41. Head Lamp exploded view.

1 Door assembly	7 Lamp housing
2 Screw	8 Grommet
3 Retaining ring	9 Lead assemblies
4 Seal beam lamp unit	10 Spring
5 Aiming screw	11 Lead connector assembly
6 Mounting ring	

d. Service Headlight Housing. (Fig 2-41)

- (1) Remove sealed beam unit as outlined in (c) above.
- (2) Disconnect three wiring harness cable connectors at rear of housing.
- (3) Remove three nuts and washers which secure housing to front end sheet metal and remove service headlight housing assembly.

e. Blackout Driving Lamp Sealed-Beam Unit. (Fig 2-42)

- (1) Remove the three screws securing door to light body.
- (2) Pull door and sealed-beam lamp assembly forward and remove waterproof connectors from connector clips.
- (3) Disconnect waterproof connectors.
- (4) Remove the lamp unit retaining springs and remove lamp unit from door.

f. Blackout Driving Light Housing. (Fig 2-42)

- (1) Disconnect electrical connector at rear of housing.
- (2) Remove nut, lock washers and centering washer which secure housing to mounting bracket.
- (3) Remove four hex socket bolts which secure lamp housing bracket to sheet metal.

(4) Remove light housing and bracket.

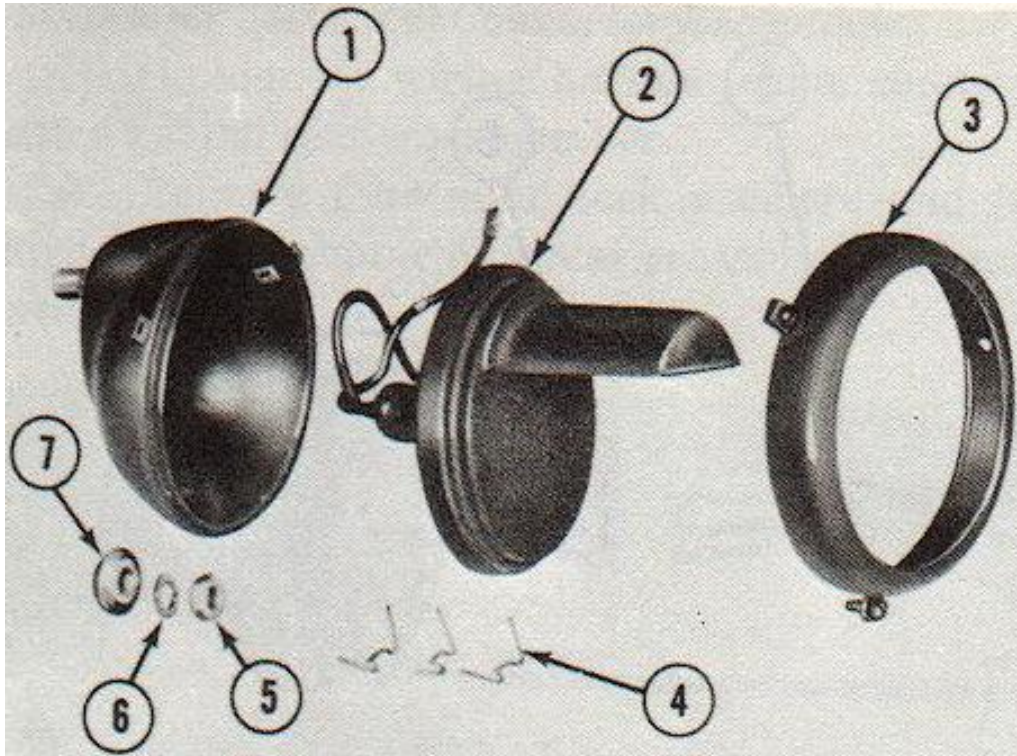

Figure 2-42. Blackout driving light exploded view.

- | | |
|-----------------|--------------------|
| 1 Housing | 5 Nut |
| 2 Blackout lamp | 6 Lock washer |
| 3 Door assembly | 7 Centering washer |
| 4 Retainer | |

g. Blackout Marker, Parking Lamp and Turn Signal Lamps.

(1) Remove 6 screws which secure door and lens to housing and remove door, lens, and seal gasket.

(2) Turn lamps counter-clockwise and remove from sockets.

h. Blackout Marker, Parking Light and Turn Signal Housing. (Fig 2-43)

(1) Disconnect electrical connectors and rear of housing.

(2) Remove two bolts and washers which secure housing to radiator support panel and remove housing.

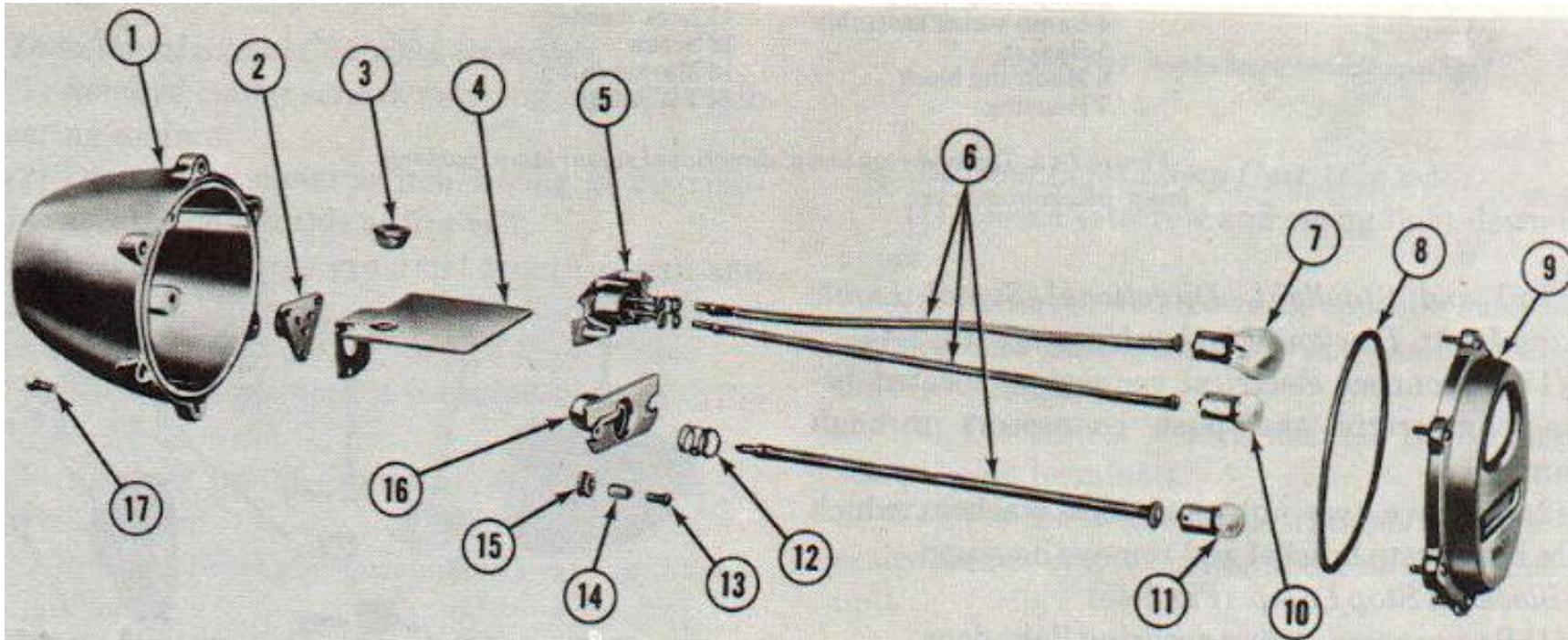

Figure 2-43. Blackout marker, parking and signal light exploded view.

1 Housing	10 Blackout marker lamp
2 Mounting block	11 Signal lamp
3 Insulator	12 Spring
4 Mounting plate	13 Screw
5 Dual socket assembly	14 Spacer
6 Lead	15 Grommet
7 Parking lamp	16 Socket assembly
8 Seal	17 Mounting screw
9 Door assembly	

i. Tail and Stop Lamp, Directional Signal Lamp, Parking Lamp, Blackout Marker. (Fig 2-44)

(1) Remove six screws which secure door and lens to housing assembly and remove door and lens.

(2) Turn lamps counter-clockwise and remove

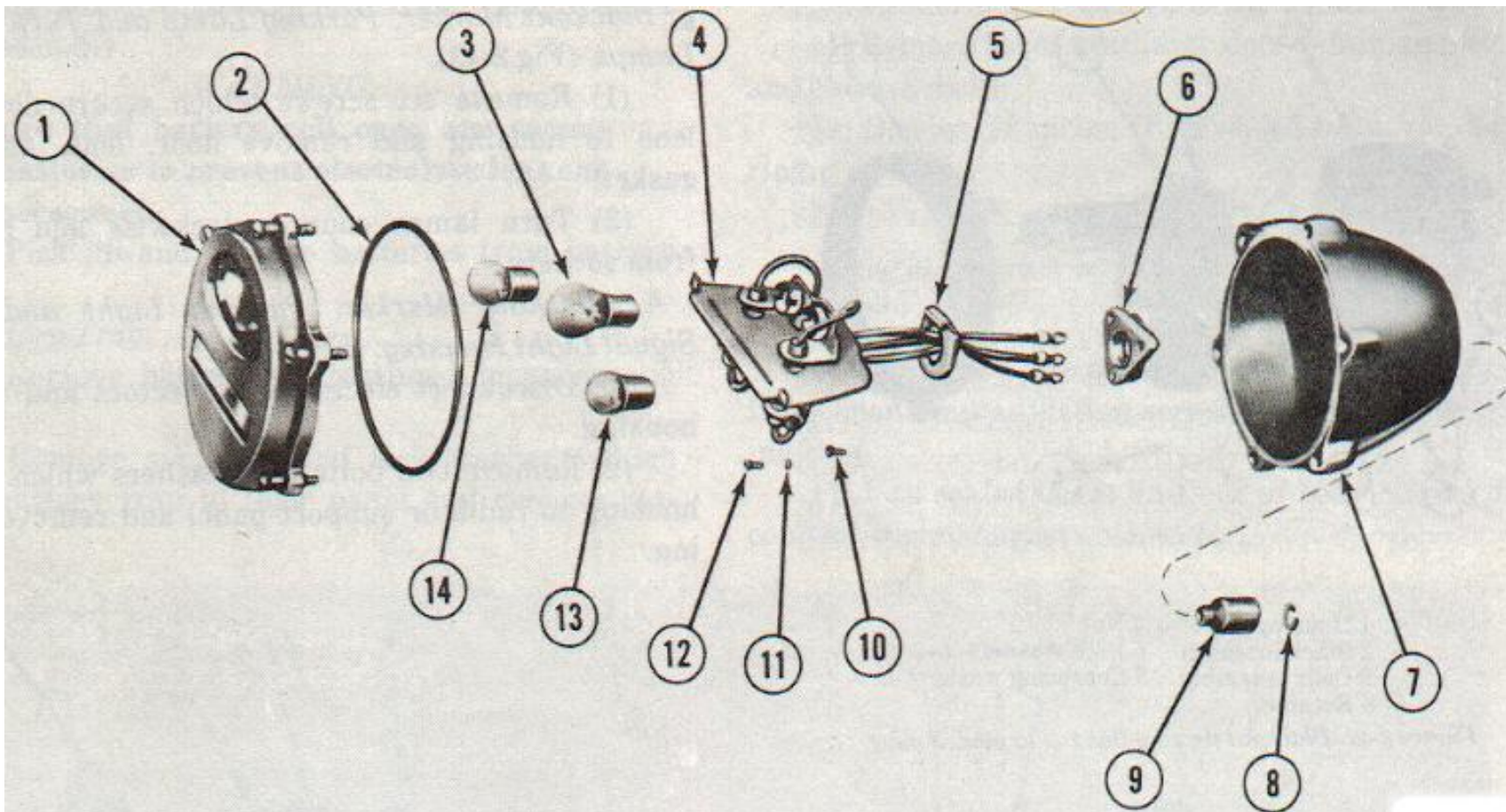

Figure 2-44 Tail and stop lamp, directional signal lamp, parking lamp, blackout marker.

1 Door assembly	8 Clip
2 Seal	9 Sleeve-rubber
3 Stop lamp	10 Mounting screw
4 Lamp socket assembly	11 Lock washer
5 Gasket	12 Screw
6 Mounting block	13 Marker lamp
7 Housing	14 Tail lamp

j. Tail and Stoplight, Directional Signal Light, Parking Light, Blackout Marker Housing. (fig 2-44)

(1) Disconnect electrical connectors located between bumperette and push connectors through grommet.

(2) Remove two nuts and lock washers which secure housing to bracket and remove housing.

k. Blackout Stop Lamp. (Fig 2-45)

(1) Remove two screws securing light door.

- (2) Remove door, lens and sealing gasket.
- (3) Press lamp in and turn lamp from socket.

1. Blackout Stop Lamp Housing. (Fig 2-45)

- (1) Remove nut and lock washer securing light assembly to support bracket.
- (2) Disconnect electrical connector and remove light housing assembly.

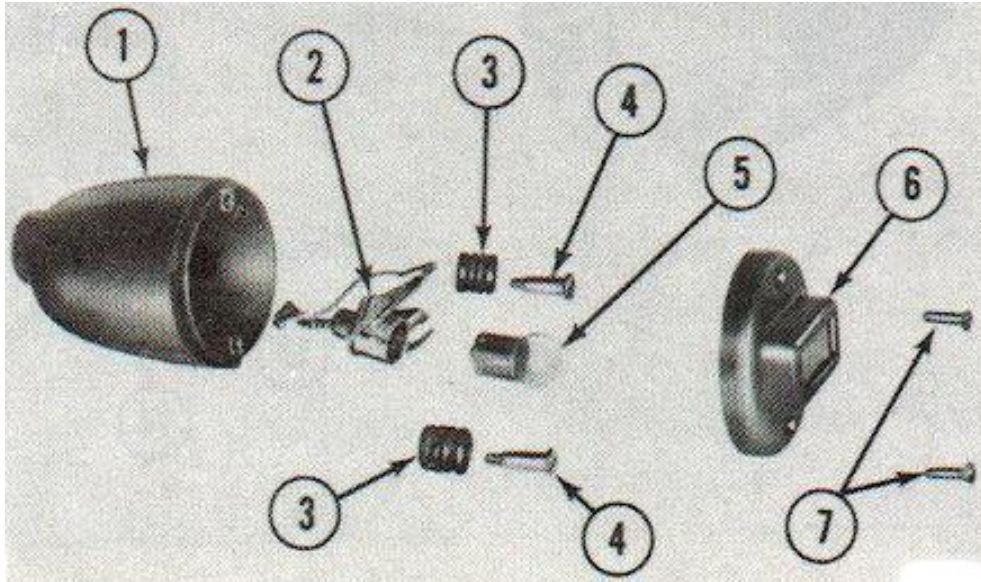

Figure 2-45. Blackout stop light - exploded view.

- 1 Housing
- 2 Socket assembly
- 3 Insulator 7 Screw
- 4 Step screw
- 5 Marker lamp
- 6 Door assembly

m. Trailer Electrical Connector Receptacle.

- (1) Disconnect wiring harness cable connectors located behind rear crossmember.
- (2) Remove four nuts, lock washers and bolts which secure receptacle to rear crossmember and remove receptacle.

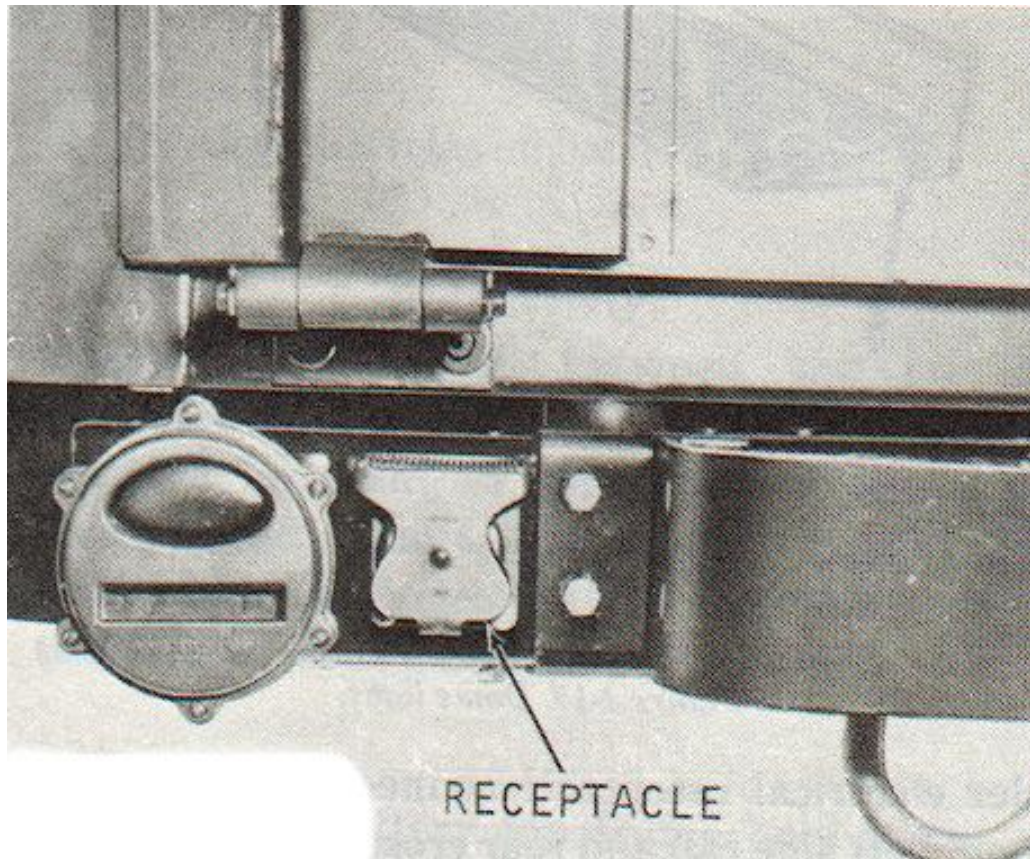

Figure 2-46. Trailer electrical coupling receptacle.

n. Directional Signal Control Assembly.

- (1) Remove clamp screws securing signal switch to Steering column.
- (2) Disconnect signal switch wiring at distribution box located on left side of firewall.
- (3) Remove harness grommet from firewall and thread harness through firewall. Remove signal switch and harness as a unit.

o. Spotlight Lamp Unit (Ambulance Only). (Fig 2-47)

- (1) Remove phillips head screw at bottom of sealed beam bezel.
- (2) Remove bezel and pull sealed beam unit from spotlight body.
- (3) Disconnect wiring harness connector and remove the sealed beam lamp unit.

p. Spotlight Assembly.

- (1) Disconnect wiring harness connector.
- (2) Loosen bolt from the split mounting bracket.
- (3) Remove nut from right side of control handle and remove bolt.
- (4) Firmly grip control handle and remove.
- (5) Remove lamp unit housing from outside of vehicle cab.

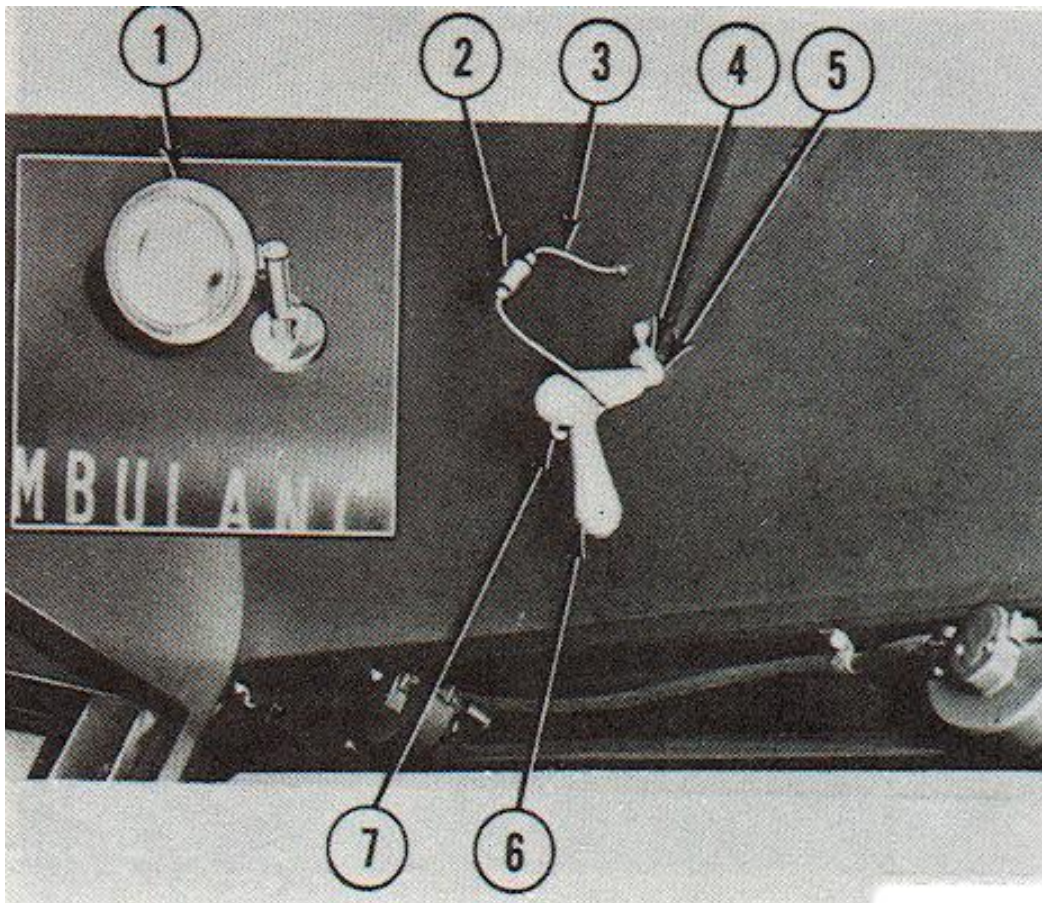

Figure 2-47. Ambulance vehicle spotlight.

- 1 Spotlight
- 2 Wire harness connector
- 3 Wire
- 4 Nut
- 5 Clamp
- 6 Control handle
- 7 Switch

q. Surgical Light Lamp Unit. (Fig 2-48)

- (1) Loosen setscrew and swing light down on ball hinge.
- (2) Remove two screws on opposite sides of lamp housing and pull grille, lens and sealed beam lamp unit from housing.
- (3) Disconnect wiring harness connectors from sealed beam terminals,
- (4) Pry back the three retainers which secure sealed beam unit to grille and remove sealed beam unit.

r. Surgical Light Housing. (Fig 2-48)

- (1) Remove six screws which secure housing to ceiling of patient compartment.

- (2) Drop light down and disconnect wiring harness connector.
- (3) Remove surgical light housing.

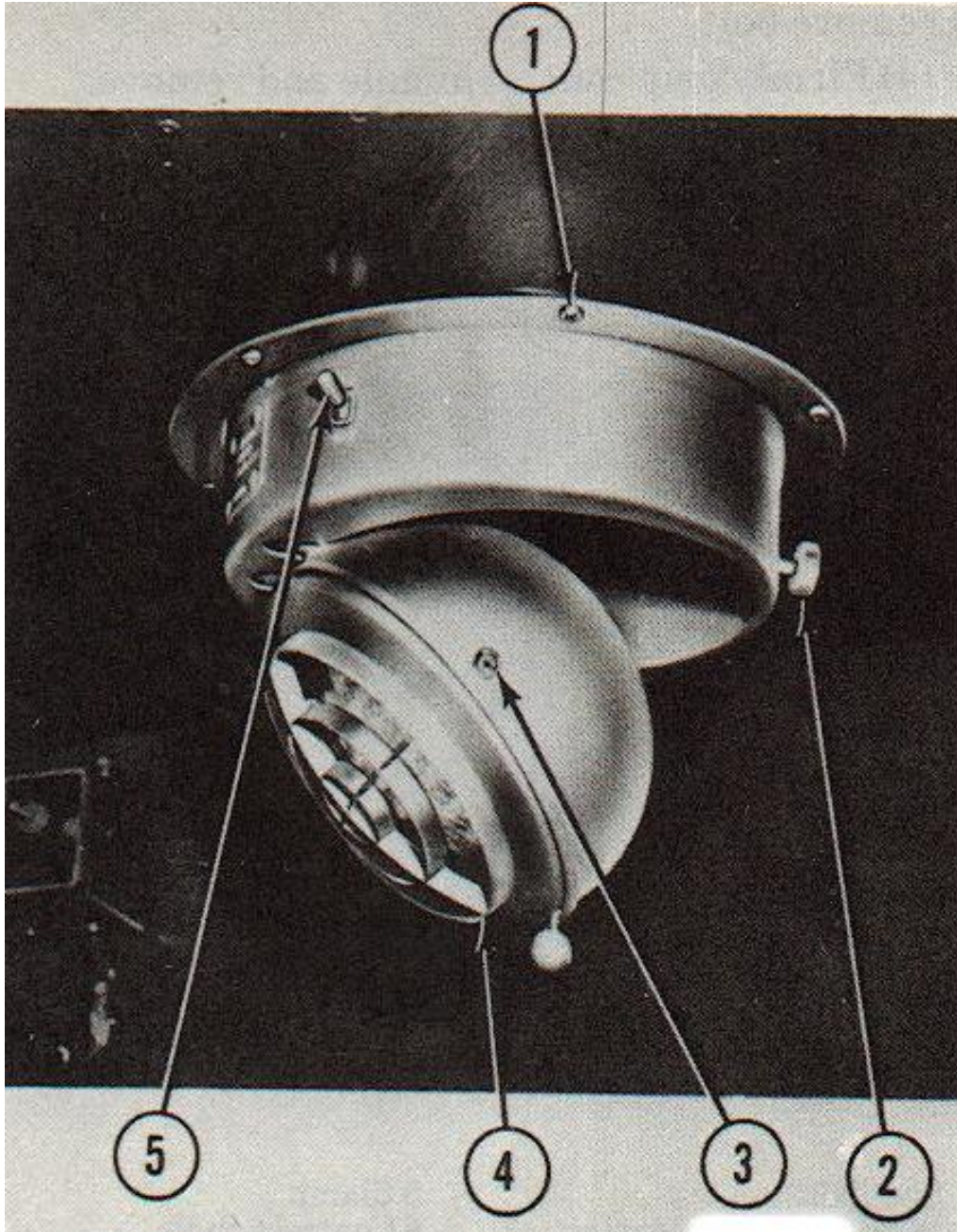

Figure 2-48. Surgical Light

1 Light mounting screw

- 2 Locking set screw
- 3 Grille mounting screw
- 4 Grille and lamp assembly
- 5 Light switch

s. Dome Light Bulb. (Fig 2-49)

- (1) Remove two screws which secure dome light lens to lamp body and remove lens.
- (2) Remove bulb by turning counter-clockwise and pulling from socket.

t. Dome Light Housing and Switch. (Fig 2-49)

- (1) Remove two screws which secure dome light housing to ambulance compartment ceiling.
- (2) Lower light housing and disconnect wiring harness connector and remove housing.
- (3) Remove ring nut which secures switch to light housing.
- (4) Disconnect wiring harness connector from switch terminals and remove switch.

u. Chassis Rear Wiring Harness.

- (1) Disconnect battery cable from battery negative terminal.
- (2) Disconnect front wiring harness connectors located on left fender apron adjacent to left rear corner of engine assembly.
- (3) Spread metal clamps which secure rear wiring harness to frame left side rail and firewall.
- (4) Spread metal clamps which secure wiring harness to frame left side rail, rear crossmember and disconnect from wiring harness.
- (5) Disconnect wiring harness connectors from fuel tank terminal, left and right rear tail lamps and trailer electrical receptacle connectors. Pull harness through left side rail and rear crossmember.
- (6) Insure that all cable disconnects have been made and remove rear wiring harness.

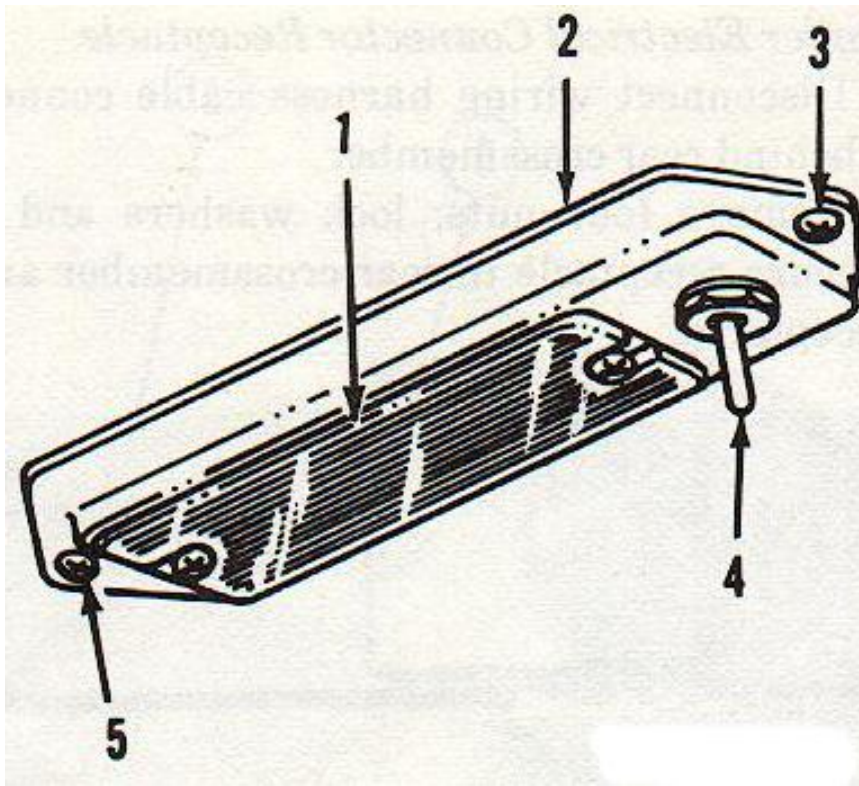

Figure 2-49. Dome light.

- 1 Lens
- 2 Dome light
- 3 Mounting screw
- 4 Lens holding screw
- 5 Switch

v. Chassis Front Wiring Harness.

- (1) Disconnect battery cable from battery negative terminal.
- (2) Disconnect front wiring harness connectors from left and right service headlamps, directional signal and blackout marker lamps, blackout drive lamp and horn assembly.
- (3) Remove plastic clamps which secure wiring harness to front end sheet metal, fender apron and firewall assembly. Spread clamps and disconnect from wiring harness.
- (4) Unscrew front wiring harness connector from oil pressure sender unit terminal located on right rear corner of engine.
- (5) Unscrew wiring harness cable terminal nut from ignitor connector located on right front corner of engine.
- (6) Disconnect wiring harness connectors from stoplight switch, distribution box, alternator, water temperature sender unit and starting motor.
- (7) Carefully disengage wiring harness from instrument panel, fender apron and firewall and remove wiring harness from vehicle.

2-68. Cleaning, Inspection and Repair.

- a. Clean dirt and corrosion from electrical connections.
- b. Clean and lightly oil all mounting bolts and nuts.
- c. Inspect electrical connectors for corrosion and frayed wires.
- d. Inspect mounting brackets for cracks and distortion.

2-69. Installation.

a. Battery Tray.

- (1) Position battery tray on floor panel.
- (2) Install six bolts and lock washers which secure battery tray to floor panel and tighten to 10-15 lbs-ft.

b. Batteries.

- (1) Position batteries on battery tray.

WARNING

Battery connections between the two batteries should be negative terminal to positive terminal to complete the negative ground circuit. Improper cable connections to batteries will damage the system and present hazards to personnel.

- (2) Position battery top frame hold-down over batteries. Insure that bolts are connected to tray bracket.
- (3) Insert top frame hold-down bolts through top frame and holes in battery tray brackets.
- (4) Install washers and attaching nuts and tighten to 14-25 lbs-ft.
- (5) Connect battery cables to battery terminals. Tighten cable terminal bolts securely.

c. Service Headlight Housing.

- (1) Position headlight housing in front end sheet metal.
- (2) Install three washers and nuts and tighten securely.
- (3) Connect three wiring harness cables to connectors on headlight housings.
- (4) Install sealed-beam lamp unit as outlined in (d) below.

d. Service Headlight Sealed-Beam Unit.

- (1) Connect wiring harness connector at rear of sealed-beam headlight unit.
- (2) Position sealed-beam unit in housing and install retaining ring over adjusting screws. Turn retaining ring to engage screws.
- (3) Connect spring to retaining ring.
- (4) Position headlight door and secure with three screws. Tighten screws securely.

e. Blackout Driving Light Housing.

- (1) Position bracket to sheet metal and install four hex socket bolts. Tighten to a firm fit.
- (2) Position driving light housing attaching bolt in bracket.
- (3) Install bearing washer, lock washer and nut. Tighten securely.
- (4) Connect electrical connector,
- (5) Tighten bracket hex socket bolts securely.

f. Blackout Driving Lamp.

- (1) Position sealed-beam lamp unit in door and secure with the three retaining springs.
- (2) Connect wiring harness cable to connector located at rear of light housing.

g. Blackout Marker, Parking Light and Turn Signal Light Housing.

- (1) Position housing through sheet metal and mounting bracket.
- (2) Install two washers and bolts; tighten securely.

(3) Connect electrical connectors at rear of housing.

h. Blackout Marker, Parking and Turn Signal Lamps.

(1) Install lamp in socket and turn ½ turn clockwise,

(2) Position lens, door and gasket to housing and install six retaining screws,

i. Tail and Stoplight, Directional Signal and Blackout Marker Housing.

(1) Position housing to bracket and install two lock washers and nuts. Tighten securely.

(2) Insert electrical cables through grommet in bumperette and connect to chassis wiring harness.

j. Tail and Stop Lamp, Directional Signal Lamp, Parking Light and Blackout Marker.

(1) Install lamp in socket and turn ½ turn clockwise.

(2) Position lens, door and gasket to housing and install six attaching screws.

k. Blackout Stop Lamp.

(1) Install new lamp in socket and turn clockwise.

(2) Install door, lens and gasket; secure with two screws.

l. Blackout Stop Lamp Housing.

(1) Connect electrical cable at rear of light hous

(2) Position light housing to support bracket and secure with nut and lock washer.

m. Trailer Electrical Connect Receptacle.

(1) Position electrical receptacle to rear cross-member and install four bolts, lock washers and nuts. Tighten securely,

(2) Connect wiring harness cable connectors located behind rear crossmember,

n. Directional Signal Control.

(1) Attach directional signal control to steering column by positioning control and securing with clamp.

(2) Connect directional signal control leads to distribution box,

o. Dome Light Housing and Switch.

(1) Install new switch.

(2) Connect wiring harness connector to switch terminals.

(3) Install ring nut which secures switch to light housing.

(4) Install light housing and connect wiring harness connector.

(5) Install screws and secure dome light housing to ambulance compartment ceiling.

p. Spotlight Assembly.

(1) Install light unit in upright position and push all the way in against cab.

(2) From the cab side, push the control handle on.

(3) Aline the flat on the shaft and replace the bolt.

(4) Replace the nut and tighten.

(5) Connect the wire.

(6) Check the unit by turning the switch to ON and OFF.

q. Surgical Light and Switch.

(1) Replace the sealed-beam lamp with an identical one, attaching it to the lamp grille with the screws and tighten.

(2) Connect the wire harness connector to the lamp and raise the assembled unit into the hinged lamp mount.

(3) Rotate the grille and lamp assembly in the mount until the screw holes are lined up.

(4) Install and tighten the two screws which hold the lamp and grille assembly to the hinged lamp mount.

(5) Swing the lamp mount into the light housing and tighten the setscrew by hand.

(6) To remove and replace the toggle switch, proceed as follows:

- (a) Disconnect the main battery terminal located under the right seat in the patient compartment.
- (b) Swing the lamp mount down from the housing by loosening the setscrew located on the housing.
- (c) Remove the ring nut from the outside of the light housing that holds the toggle switch in place. Allow the switch to fall inside the housing.
- (d) Remove the two switch terminal screws and disconnect the wire harness Connector.
- (e) Replace the switch with an identical one.
- (f) Reconnect the wire harness connectors and tighten the terminal screws.
- (g) Place the new toggle switch in the fitting hole on the housing and hand tighten the ring nut, holding it in place. Wrench tighten the ring nut.

NOTE

Aline the switch so that it operates vertically; OFF in the down position; ON in the up position.

- (h) Reconnect the main battery terminal,
- (i) Test the switch and light for proper operation.

Section XVIII. INSTRUMENT PANEL, INSTRUMENTS, SWITCHES, INDICATORS, SENDING UNIT. HORN AND LIGHTS

2-70. General.

The speedometer (with Odometer), battery/alternator indicator, fuel level indicator, temperature indicator, oil pressure indicator, headlight high beam indicator lamp, and instrument panel illumination lamps are mounted in the instrument panel. This panel, together with the mounted instruments and lamps, is referred to as the instrument cluster (fig 2-50). Refer to the operator s manual, TM 9-2320-244-10 for location and operation of the various switches, indicators and panel lamps.

The horn is of the vibrator type, electrically operated through the horn switch, and is waterproof. The horn is mounted on the fender apron sheet metal and is connected to the horn button by a cable.

2-7 1. Maintenance and Adjustment.

Refer to Table 2-2 for maintenance inspection procedures.

2-72. Removal.

a. Instrument Cluster.

- (1) Disconnect all bayonet connections at the back of the instrument panel. (Fig 2-5 1)
- (2) Disconnect speedometer cable and housing from speedometer/odometer assembly at rear of instrument cluster.
- (3) Loosen the DZUS Fastener at each corner of the instrument cluster one quarter turn counterclockwise and remove instrument cluster from instrument panel.

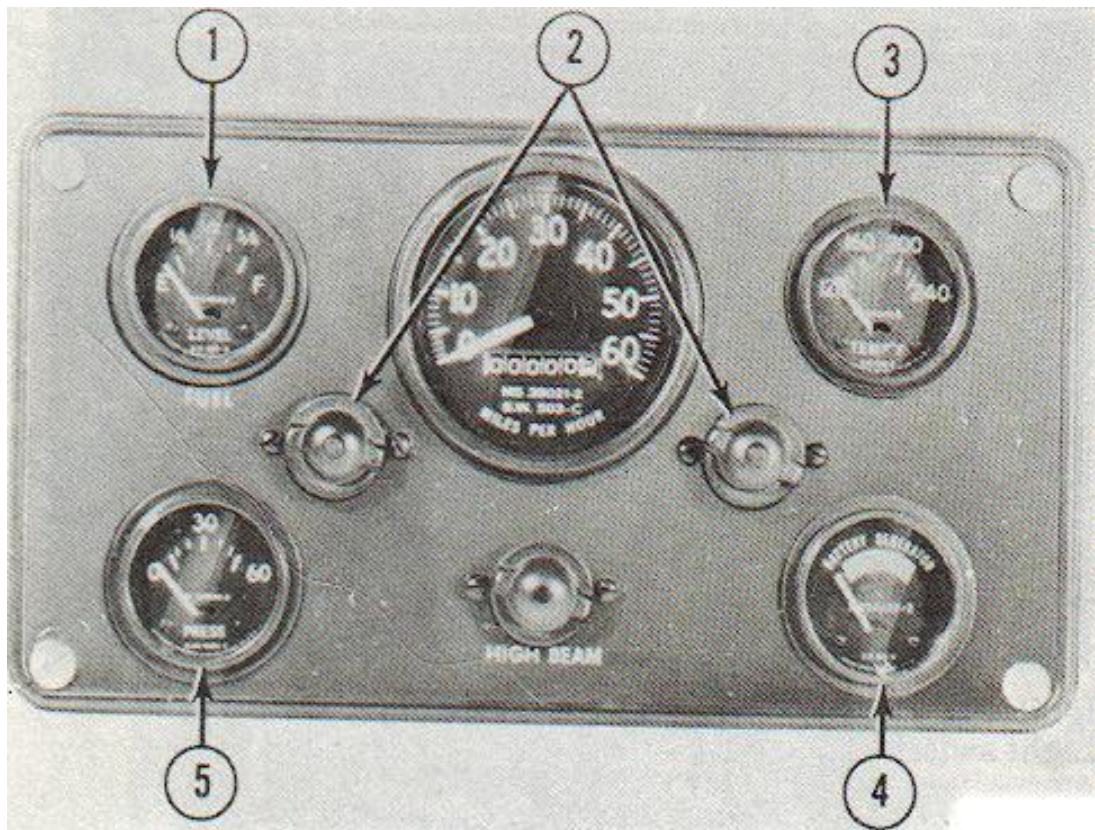

Figure 2-50. Instrument cluster - front view.

- 1 Fuel gage
- 2 Panel lights
- 3 Temperature gage
- 4 Battery generator indicator
- 5 Oil pressure gage

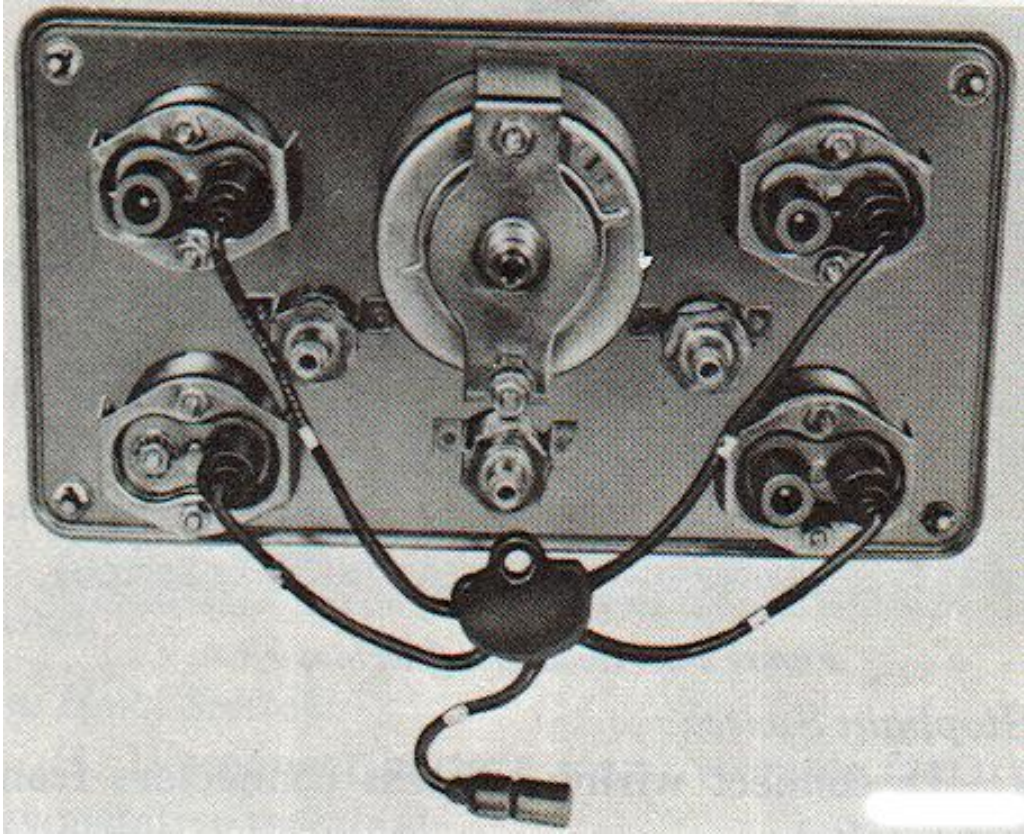

Figure 2-51. Instrument cluster rear view.

b. Speedometer Cable, Housing and Driven Gear.

- (1) Disconnect speedometer cable and housing from speedometer and speedometer adapter fitting on transfer case using Tool FSN 5120-168-2348.
- (2) Remove speedometer gear retaining unit, oil seal and speedometer driven gear from transfer case.
- (3) Slide speedometer cable housing assembly through hole in cowl and remove cable and housing assembly from the vehicle.

c. Fuel, Oil, Temperature, Battery - Generator Indicators.

- (1) Remove instrument cluster from instrument panel.
- (2) Disconnect the two bayonet connections from the indicator terminals.
- (3) Remove the two nuts and lock washers securing the indicator clamp to the back of the indicator. Remove clamp and pull indicator out of the front of the cluster panel.

d. Speedometer/Odometer.

- (1) Remove instrument cluster from instrument panel as outlined in (a) above.
- (2) Disengage cable connector from clip on speedometer clamp.
- (3) Remove nut and lock washer from two speedometer clamp studs. Remove cable connector clip from one stud and remove molded electric lead splice from other stud.
- (4) Remove long stud and lock washer securing clamp to speedometer. Remove clamp, then remove speedometer from front of cluster panel.

e. Temperature Indicator Sending Unit. (Fig 2-52)

- (1) Disconnect cable from sending unit terminal.
- (2) Unscrew and remove sending unit from the forward Section of the intake manifold.

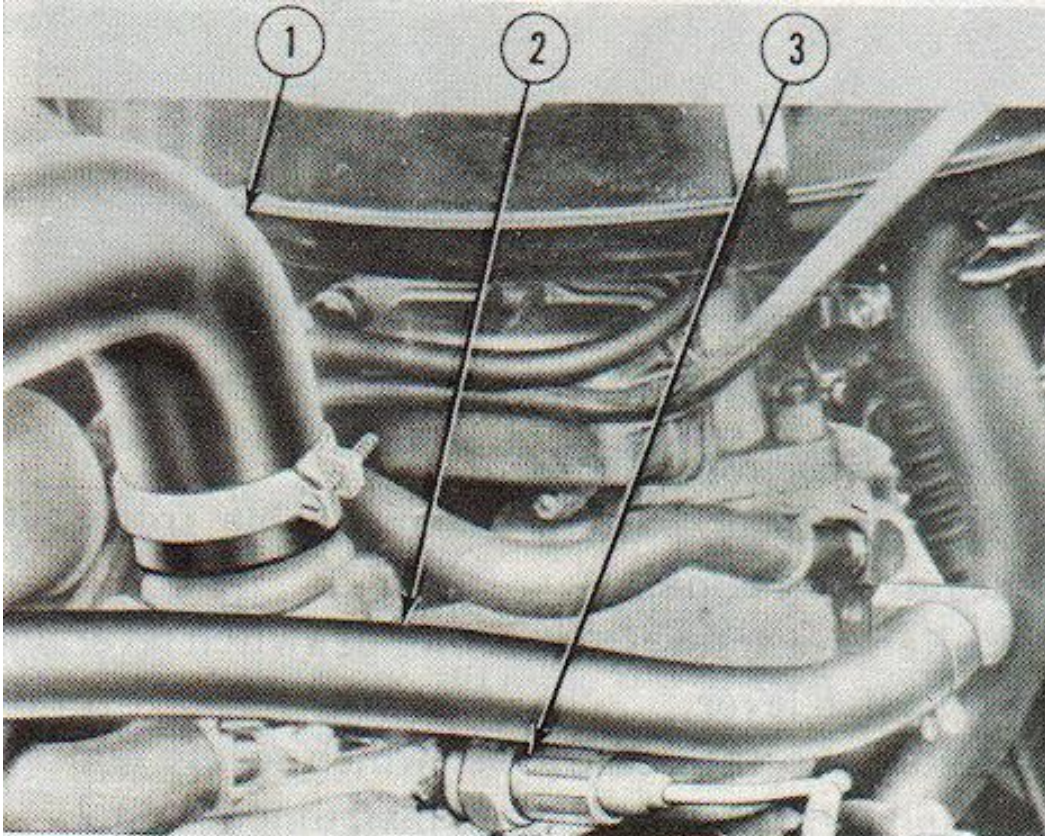

Figure 2-52. Temperature sending unit

- 1 Engine coolant outlet hose
- 2 Thermostat housing
- 3 Temperature sending unit

f. Oil Pressure Sending Unit. (Fig 2-52)

- (1) Disconnect cable from terminal of sending unit.
- (2) Unscrew sending unit from fitting on right rear of engine cylinder block.

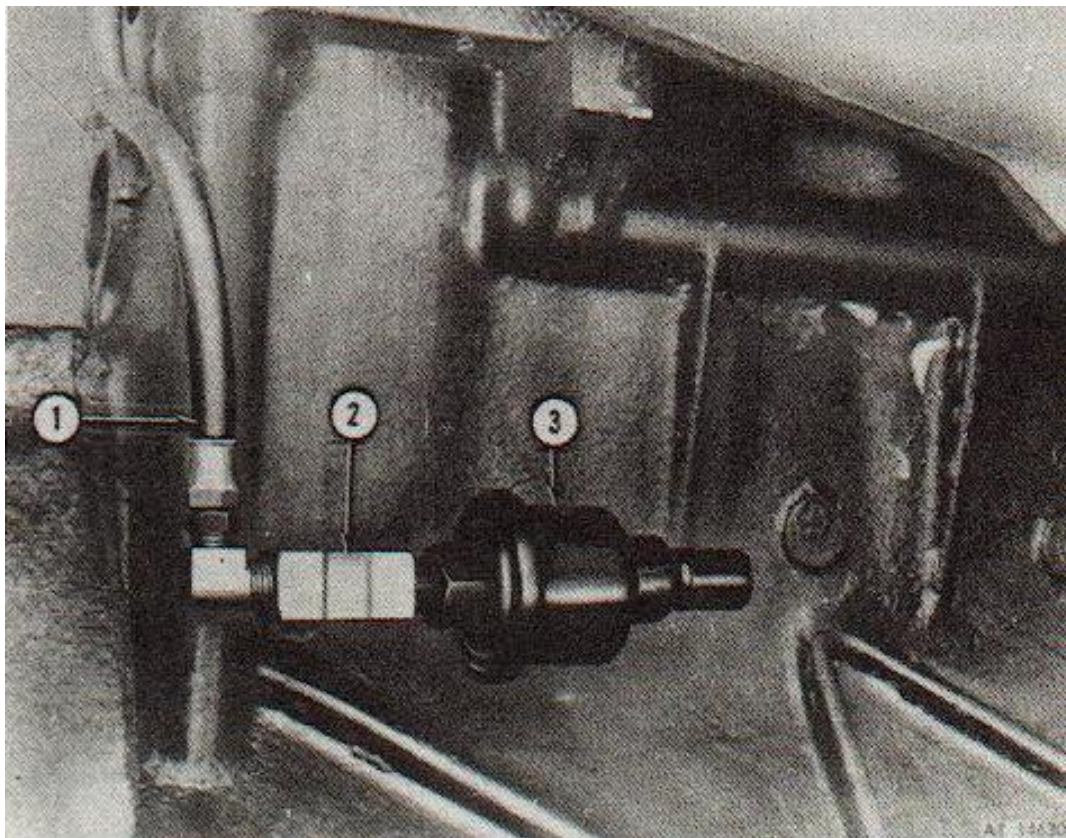

Figure 2-53. Oil pressure sending unit.

- 1 Flexible oil line
- 2 Tee
- 3 Sending unit

g. Horn. (Fig 2-54)

- (1) Disconnect electrical connector from horn.
- (2) Remove two bolts and lock washers which secure horn to fender apron sheet metal and remove horn.

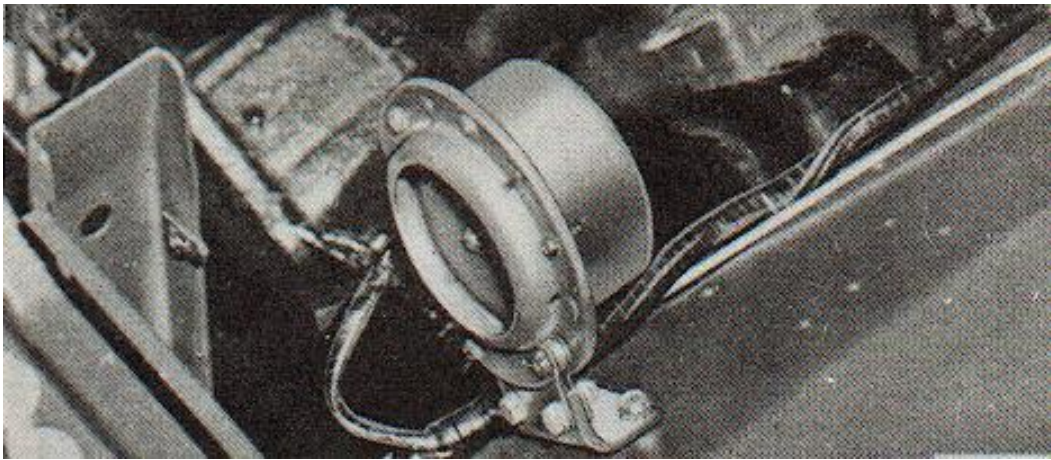

Figure 2-54. Horn assembly.

h. Ignition Switch. (Fig 2-55)

- (1) Disconnect battery ground cable from battery negative terminal.
- (2) Remove screw from center of switch lever and remove switch lever.
- (3) Remove nut and washer which secure ignition switch and switch nameplate to instrument panel.
- (4) Insert hand behind instrument panel and disconnect ignition switch cable connectors.
- (5) Grasp switch and remove from instrument

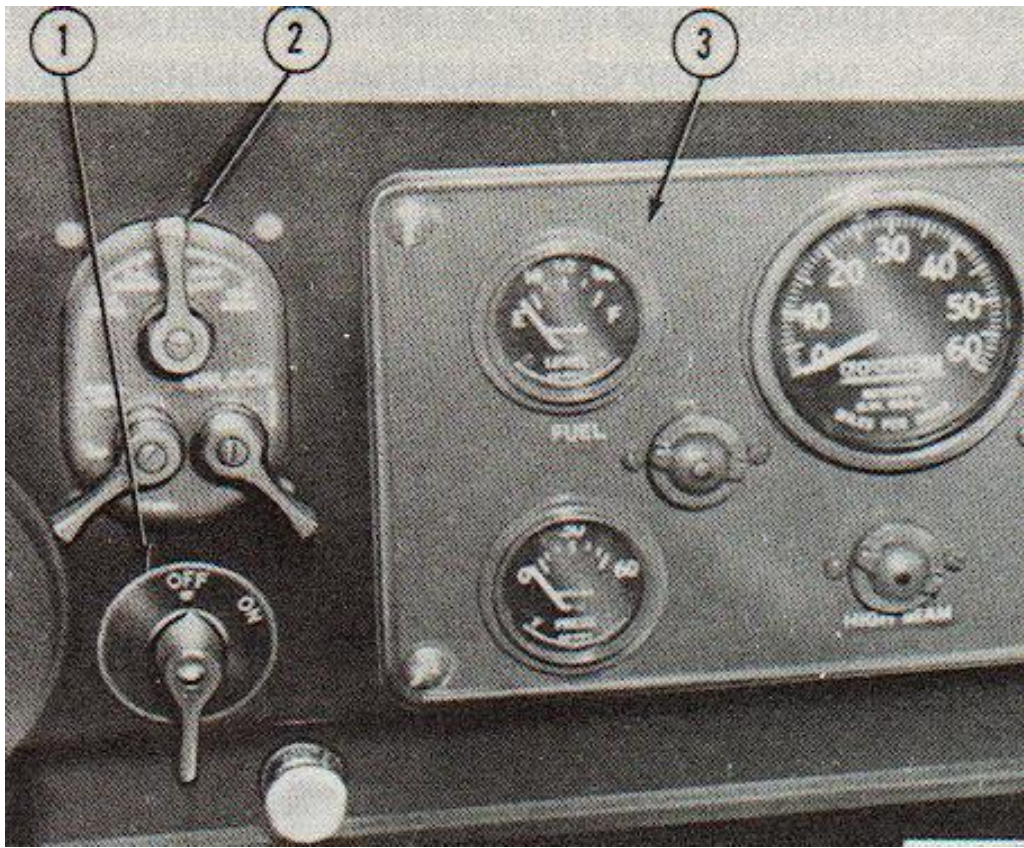

Figure 2-55. Ignition switch.

- 1 Ignition switch
- 2 Light switch
- 3 Instrument cluster

i. Headlight Selector Switch. (Fig 2-56)

- (1) Remove two screws which secure selector switch to cab floor panel.
- (2) Separate the electrical connectors from switch terminals and remove switch.

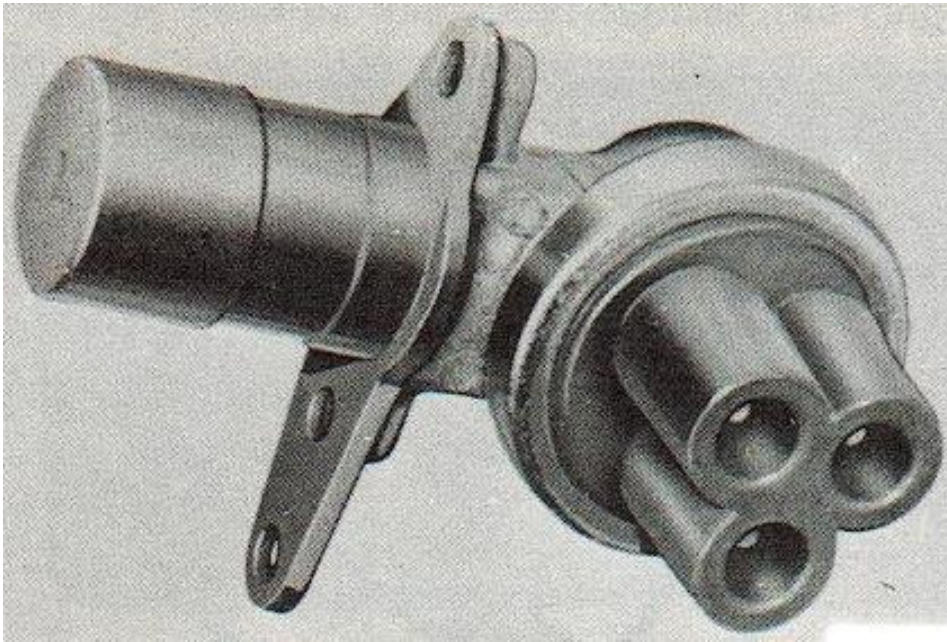

Figure 2-56. Headlight selector switch.

j. Stoplight Switch.

- (1) Disconnect wiring harness connectors from stoplight switch.
- (2) Unscrew and remove switch from hydraulic line junction block.

k. Starter Switch. Refer to paragraph 2-57b for removal procedures.

1. Main Light Switch. (Fig 2-57)

- (1) Remove four bolts, nuts and lock washers which secure light switch to instrument panel.
- (2) Insert hand behind instrument panel and disconnect wiring harness at light switch.
- (3) Remove light switch.

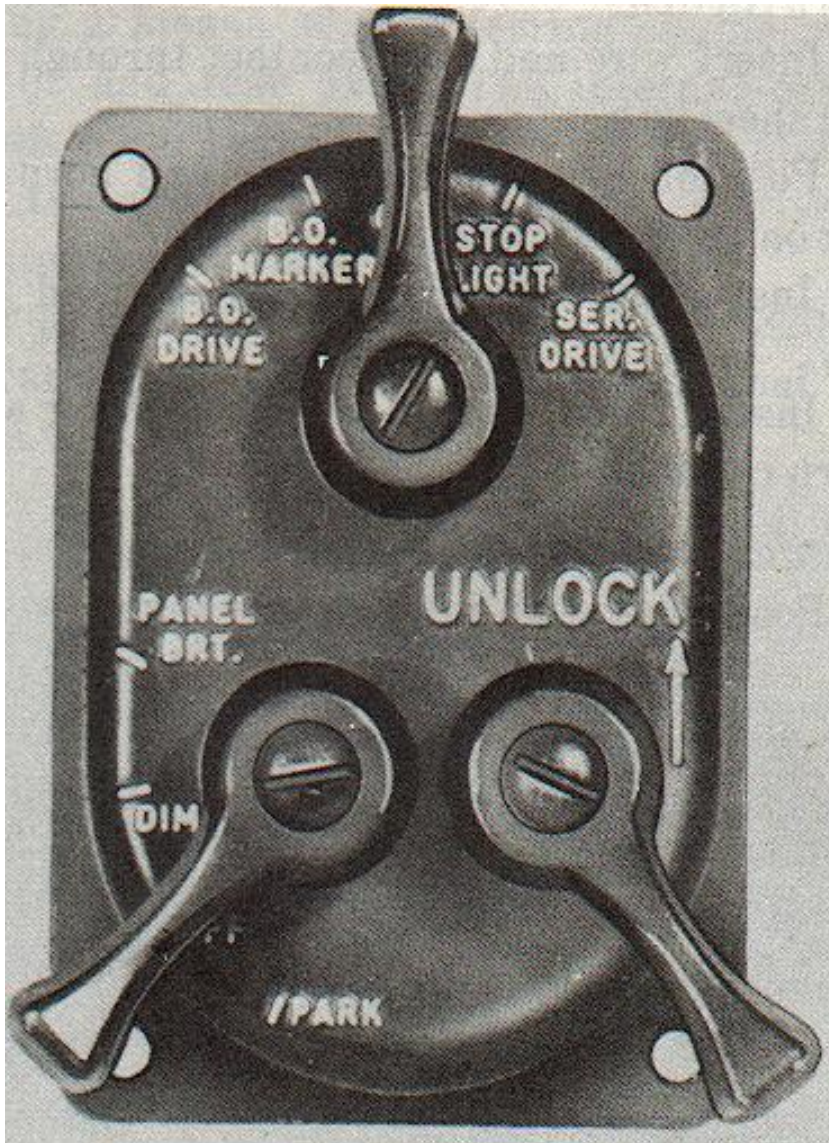

Figure 2-57. Main Light Switch.

m. Ventilator Blower Switch (Ambulance Only).

- (1) Disconnect battery cable from battery negative terminal.
- (2) Remove two screws which secure switch mounting plate to ambulance body.
- (3) Pull switch plate out and disconnect wiring harness connectors.
- (4) Remove nut from front of switch and remove switch.

n. Horn Switch.

- (1) Disconnect battery negative cable from battery negative terminal.
- (2) Remove horn button by pulling straight away from steering wheel hub.

- (3) Disconnect wiring harness cable connector on outside of steering column.
- (4) Remove three screws which secure horn lower contact plate to steering wheel hub.
- (5) Remove horn button retainer and lower contact plate.
- (6) Remove horn contact and wire from steering wheel hub.

2-73. Cleaning, Inspection and Repair.

- a. Clean all electrical terminals of rust and corrosion.
- b. Inspect electrical cables and connectors for frayed insulation, broken wires or connectors.
- c. Replace connectors and lamps as required.
- d. Inspect speedometer cable for frayed or broken wires; lubricate or replace as required.

2-74. Installation.

a. Speedometer Cable, Housing and Gear.

- (1) Install speedometer driven gear into transfer case.
- (2) Position speedometer cable and housing assembly in the vehicle and thread housing to the drive adapter on rear of transfer case using Tool FSN 5120-168-2348.
- (3) Slip speedometer cable and housing through firewall and thread coupling to rear side of speedometer.

b. Speedometer/Odometer.

- (1) Position speedometer in instrument cluster front side. Position clamp over speedometer at back of cluster; install long stud and lock washer, and nut and lock washer securing clamp to speedometer.
- (2) Place molded electric lead splice on long stud and secure with lock washer and nut. Engage cable connector in clip.
- (3) Install instrument cluster in instrument panel and secure by turning DZTJS fastener ¼ turn clockwise.

c. Fuel, Oil, Temperature and Battery-Generator Indicators.

- (1) Install indicators in front side of cluster. Position clamp over back of indicator and secure with two nuts and lock washers.
- (2) Connect the two bayonet connections to the oil pressure indicator terminals.
- (3) Install the instrument cluster to the instrument panel and secure by turning DZUS fastener 1/4 turn clockwise.

d. Instrument Cluster.

- (1) Position instrument cluster to instrument panel and secure by turning the DZUS fastener at each corner of the instrument cluster 1/4 turn clockwise.
- (2) Connect all bayonet connections at the back of the instrument cluster.

NOTE

Make sure the wiring identify is mated at the instrument cluster gages and harness connections.

- (3) Connect speedometer cable and housing assembly to rear of speedometer.

e. Horn.

- (1) Position horn assembly on left front fender apron sheet metal.
- (2) Install two bolts and lock washers which secure horn to sheet metal.
- (3) Connect electrical cable to horn connector.

f. Ignition Switch.

- (1) Connect harness cables to ignition switch cables, making sure cable numbers are matched.
- (2) Insert shaft end of switch through hole in instrument panel from the back side, with locating pin in switch engaging locating hole in panel. Install nameplate, lock washer and nut on switch and tighten securely.

(3) Install switch lever on switch shaft and secure with screw and lock washer.

(4) Connect battery negative cable to battery negative terminal.

g. Headlight Selector Switch.

(1) Position switch on mounting plate and secure with two lock washers and screws.

(2) Identify electrical cables and connect to proper switch connectors.

(3) Position selector switch and mounting plate to cab floor panel and install three lock washers and screws, Tighten screws securely.

h. Stoplight Switch.

(1) Thread stoplight switch into hydraulic line junction block and tighten securely.

(2) Connect cable connectors.

(3) Bleed hydraulic system after switch installation.

i. Starter Switch. Refer to paragraph 2-59a for installation procedures.

j. Main Light Switch.

(1) Insert switch through mounting hole in instrument panel.

(2) Insert hand under instrument panel and connect wiring harness terminal to rear of main light switch.

(3) Install four bolts, lock washers and nuts which secure switch to instrument cluster.

k. Horn Switch.

(1) Insert wire and horn contact through hole in steering wheel hub.

(2) Position horn contact plate and horn button retainer on steering wheel hub.

(3) Install three attaching screws and tighten securely.

(4) Install horn button cap by pushing straight onto horn retainer.

l. Ventilator Blower Switch (Ambulance Only).

(1) Position switch in plate and install attaching nut.

(2) Connect wiring harness connectors.

(3) Position switch mounting plate to ambulance body and secure with two attaching screws. Tighten screw securely.

m. Temperature Indicator Sending Unit.

(1) Install the sending unit into the forward section of the intake manifold.

(2) Connect cable to the temperature gage sending unit.

n. Oil Indicator Sending Unit.

(1) Thread sending unit into fitting on right rear of cylinder block and tighten securely.

(2) Connect cable to terminal on sending unit.

Section XIX. MAINTENANCE OF TRANSMISSION, GEARSHIFT AND CONTROL

2-75. General.

The transmission assembly is a conventional four speed, constant-mesh type providing synchromesh action in second, third and fourth speeds. All gears are helical design except first and reverse. The gear-shift housing assembly is attached to the top of the transmission. A standard commercial four speed shift pattern is used. Gears within the transmission are shifted by the gearshift lever which extends from the housing into the driver's compartment. The gear-shift lever and housing are sealed by a rubber boot to prevent water from entering the transmission. The transmission is vented through a plastic tube to the engine compartment. A filler plug is located on the right side of the transmission case and a drain plug is located at the bottom.

2-76. Maintenance and Adjustment.

- a. General. Refer to the Lubrication Order LO 9-2320-244-12 for periodic lubrication services.
- b. Draining Transmission.
 - (1) Place a suitable container under the transmission drain plug.
 - (2) Remove drain plug and allow lubricant to drain completely.
 - (3) Reinstall drain plug and tighten to 30-35 lbs-ft.
- c. Filling Transmission.
 - (1) Remove filler plug located on the right side of transmission case.
 - (2) Install 6½ pints of proper seasonal grade lubricant,
 - (3) Install filler plug and tighten securely. (4) Remove container from under vehicle.

2-77. Gearshift Lever Removal.

- a. Loosen rubber boot clamp and jam nut on shift lever.
- b. Turn shift lever counter-clockwise and remove from transmission.

2-78. Gearshift Lever Installation.

- a. Install gearshift lever and turn clockwise until tight.
- b. Tighten gearshift lever jam nut securely against gearshift lever. Install rubber boot and tighten clamp.

SECTION XX. MAINTENANCE OF TRANSFER CASE ASSEMBLY

2-79. General. (Fig 2-58).

The transfer case assembly is a dual-range type providing a means of transferring engine power to the front and rear axles. The internal expanding shoe type hand brake and drum are mounted at the rear of the assembly. The speedometer drive pinion is actuated by the transfer driven shaft. Refer to the Operator s Manual, TM 9-2320-244-10, for location of controls and operational fundamentals. Refer to figure 2-59.

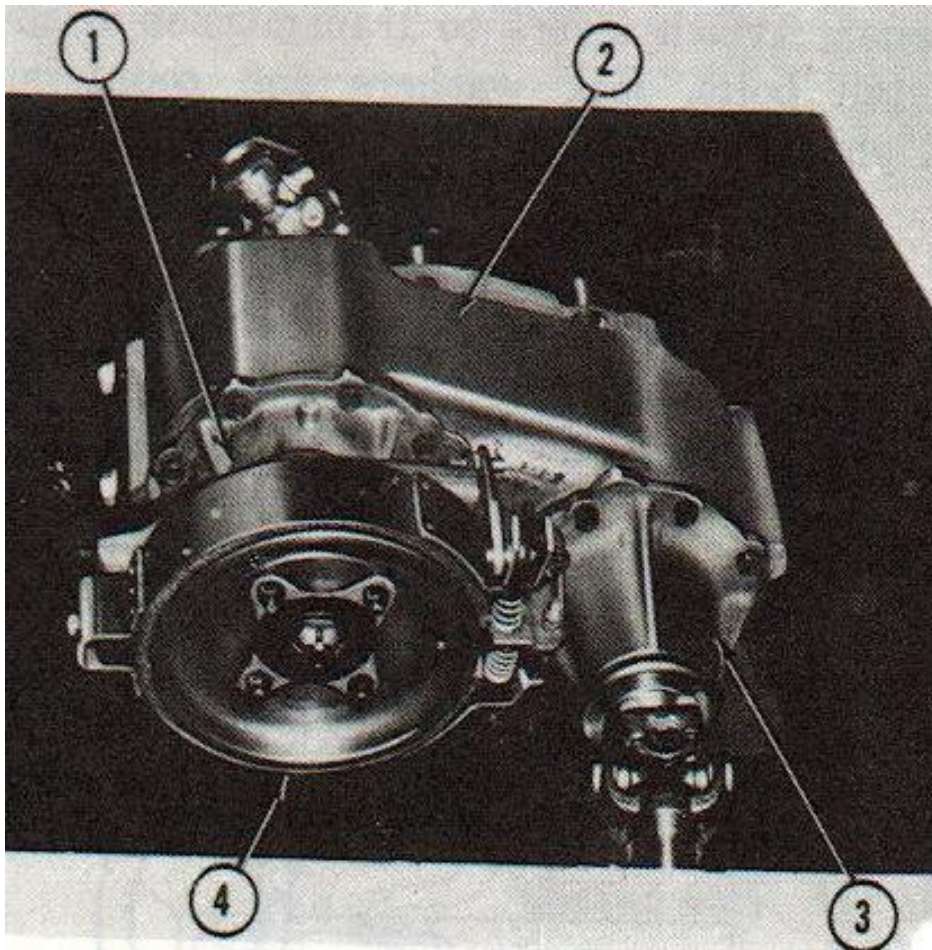

Figure 2-58. Transfer case assembly with parking brake installed.

- 1 Brake output shaft bearing retainer assembly
- 2 Transfer case assembly
- 3 Rear axle output shaft bearing assembly
- 4 Brake assembly

2-80. Maintenance and Adjustment.

a. General. Refer to the Lubrication Order, LO 9-2320-244-12, for periodic lubrication services and prescribed lubricant for all temperature ranges.

b. Draining Transfer Case.

- (1) Place a suitable container under transfer case assembly.
- (2) Remove drain plug located at the bottom right side of transfer case assembly.
- (3) Allow lubricant to drain completely.
- (4) Reinstall drain plug and tighten securely.

c. Filling Transfer Case.

- (1) Remove filler plug located at the left side of transfer case.
- (2) Fill to filler plug level, 5 pints, with proper seasonal grade lubricant.
- (3) Install filler plug and tighten securely.
- (4) Remove container from under vehicle.

2-81. Removal.

a. Control Levers and Linkage. (Fig 2-60)

- (1) Remove transfer case control levers to transmission bracket bolts.
- (2) Disconnect shift control levers from transmission and pull lever through floor panel.
- (3) Remove cotter pins and flat washers from control rods to transfer case shift rails. Remove control rods.

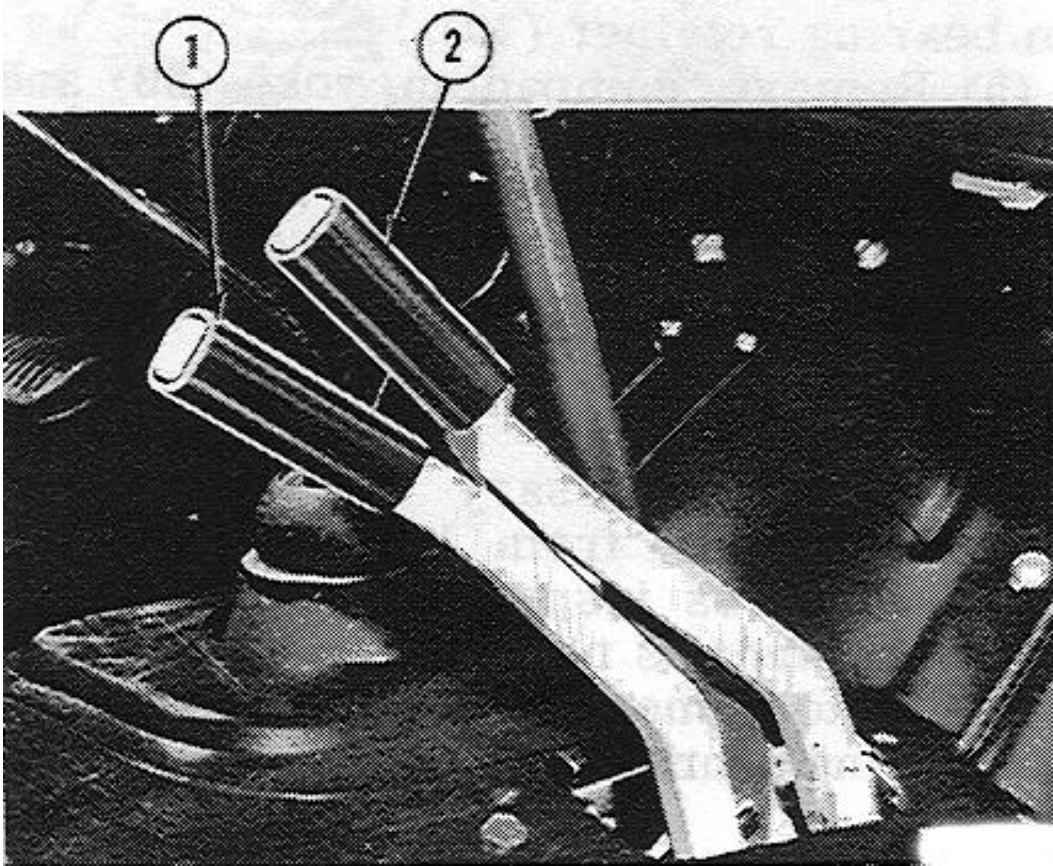

Figure 2-59. Transfer case shift levers.

- 1 De-clutch lever
2 Shift lever

b. Transfer Case Assembly.

- (1) Disconnect transfer case linkage as described in (a) above.

- (2) Disconnect the transmission to transfer case propeller shaft as described in paragraph 2-86a.
- (3) Disconnect the front and rear propeller shafts as described in paragraph 2-86b.
- (4) Unscrew speedometer cable housing retaining nut from adapter using tool FSN 5120-168-2348, Pull cable out of adapter.
- (5) Remove cotter pin from parking brake rod clevis pin. Remove clevis pin and disconnect clevis from parking brake lever.
- (6) Disconnect transfer case ventilation hose.
- (7) Remove four nuts, lock washers and bolts which secure transfer case to frame mounting bracket.
- (8) Remove transfer case and mounting cushions.

2-82. Cleaning and Inspection.

- a. Refer to paragraph 2-12 for general cleaning procedures.
- b. Inspect mounting brackets and cushions for cracks and distortion.
- c. Clean and lightly oil threads of all attaching bolts and nuts.
- d. Inspect mounting bolts and nuts for damaged threads.
- e. Replace parts that are unserviceable.
- f. If new transfer case is to be installed, transfer mounting brackets and cushions to new assembly.

NOTE

With transfer case out of vehicle, fill assembly with 5 pints of lubricant as specified in Lubrication Order, LO 9-2320-244-12. Install filler plug and tighten securely. Turn transfer case over to allow lubricant to flow into the rear output bearing cavity.

2-83. Installation.

a. Transfer Case.

- (1) Position transfer case and mounting cushions to frame mounting brackets.
- (2) Install four attaching bolts, lock washers and nuts, tighten to 80-120 lbs-ft.
- (3) Position parking brake rod clevis to lever and install clevis pin. Install cotter pin in clevis pin.
- (4) Install speedometer cable in adapter and tighten housing retaining nut using Tool FSN 5120-168-2348.
- (5) Install front and rear axle and transmission propeller shafts as outlined in paragraph 2-90a and b.
- (6) Attach transfer case control lever and linkage as described in (b) below.

b. Control Lever and Linkage. (Fig 2-60)

- (1) Connect control rods to transfer case shift rail links. Position flat washers on rod ends and install cotter pins.
- (2) Insert control levers through access hole in floor panel. Attach levers to transmission bracket and install bolts, lock washers and countersink screw. Tighten to 14-25 lbs-ft.

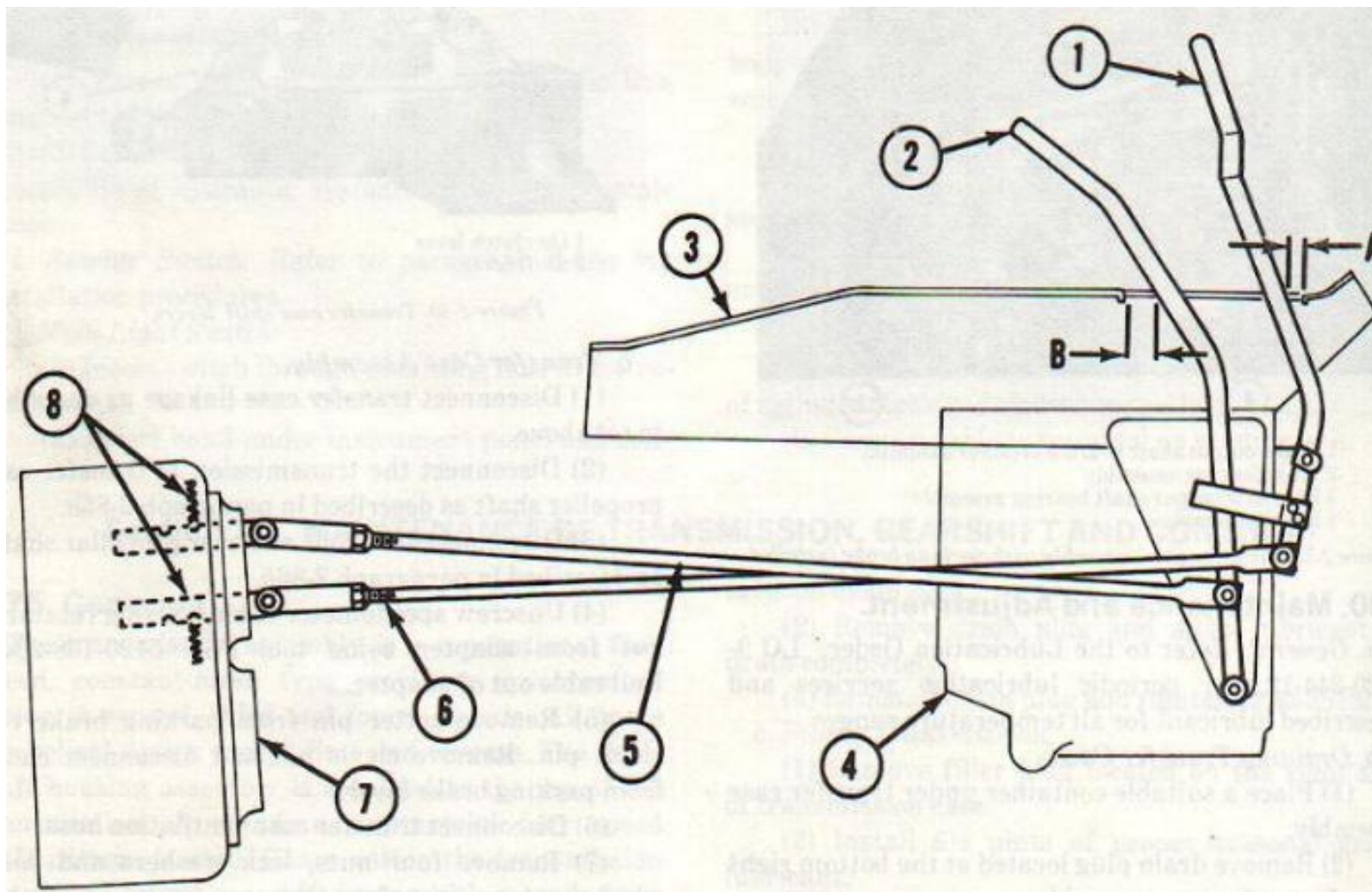

Figure 2-60. Transfer case shift rod assembly

- | | |
|----------------------------|--------------------------|
| 1 Shift lever | 5 Control de-clutch rod |
| 2 De-clutch lever | 6 Control shift rod |
| 3 Transmission floor cover | 7 Transfer case |
| 4 Transmission | 8 Poppet ball and spring |

Section XXI. MAINTENANCE OF PROPELLER SHAFTS AND UNIVERSAL JOINTS

2-84. General.

The vehicle driveline system has a front, intermediate and rear propeller shaft of welded steel tubing, with forged steel yokes at each end (fig 2-61). Extended life carbon type universal joints, which require periodic inspection and lubrication, are retained in the yokes by U-bolts, nuts and snap rings. The universal joints consist of a cross-type trunnion, needle rollers, outer bearing races and seals. The needle bearings are retained on the journals of the trunnion by the outer bearing races. The yokes, located on the transfer case end of the front and rear propeller shafts, incorporate a splined slip joint to

compensate for variations in distance between the axles and transfer case. Lubrication fittings are provided on the propeller shaft housings to lubricate the splines.

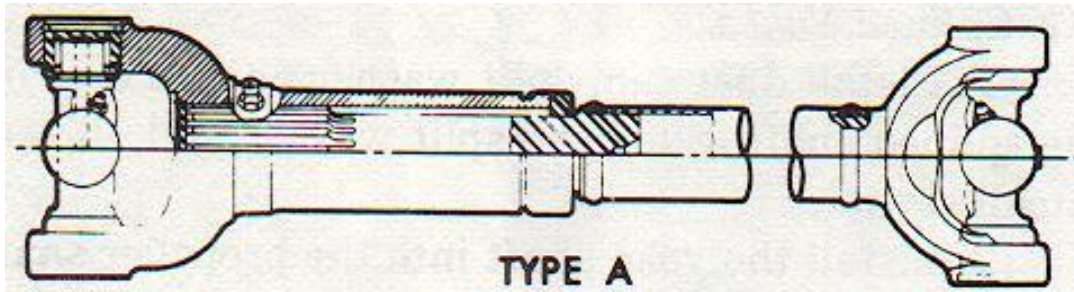

Figure 2-61. Typical propeller shaft.

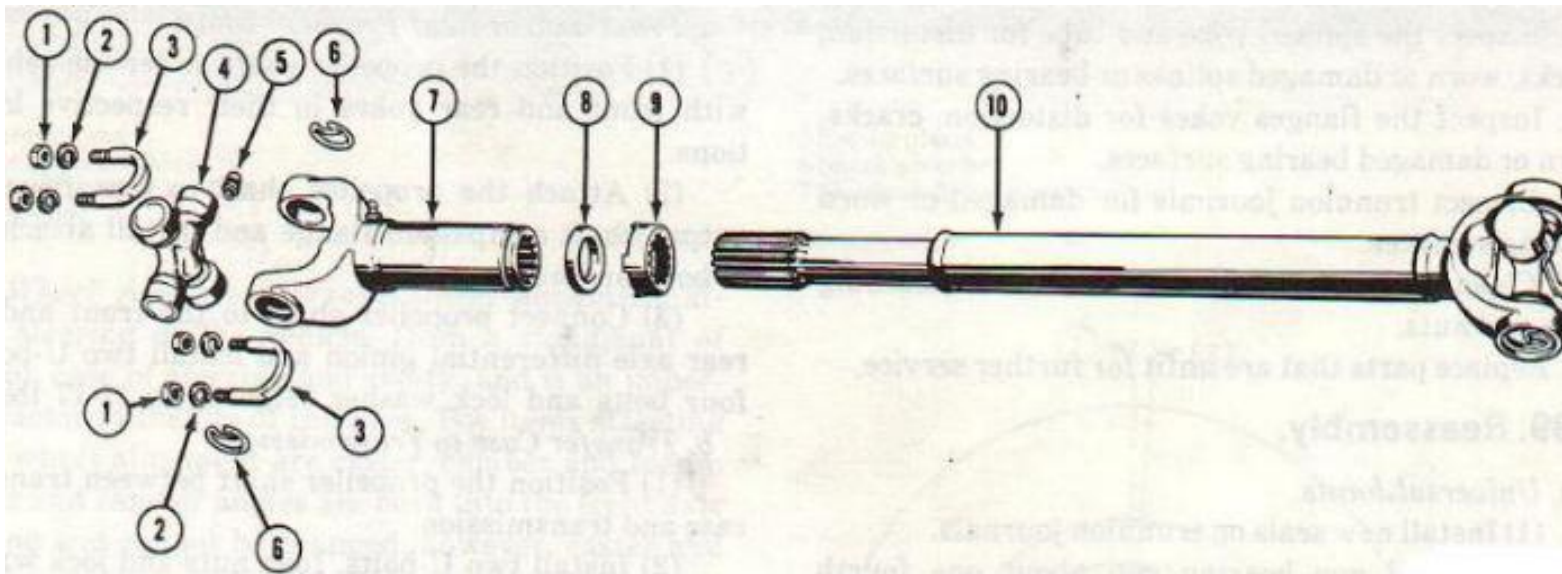

Figure 2.62. Propeller shaft and universal joint.

1 U-bolt nut	6 Snap ring
2 U-bolt washer	7 Universal joint sleeve yoke
3 U-bolt	8 Spline seal
4 Universal joint journal	9 Dust cap
5 Lubrication fitting	10 Propeller shaft tube

2-85. Maintenance and Adjustment.

Refer to Lubrication Order, LO 9-2320-244-12, for lubrication instructions.

2-86. Removal.

a. Transmission to Transfer Case.

- (1) Block front and rear wheels and release parking brake. Shift transmission into any gear and transfer case into 2-wheel drive, high gear.
- (2) Remove four nuts and two attaching U-bolts which connect the propeller shaft to the transmission output shaft universal joint yoke and disconnect propeller shaft.
- (3) Remove four nuts, lock washers and two U-bolts which connect the propeller shaft to transfer case input shaft companion flange.
- (4) To free the journals from the end yokes, loosen the transfer case support attaching bolts and slide the transfer back in the slotted bracket holes.
- (5) Remove transmission to transfer case propeller shaft assembly.

b. Front and/or Rear Propeller Shaft. (Fig 2-62)

- (1) Remove four nuts, lock washers and two attaching U-bolts which connect propeller shaft to front and/or rear axle differential pinion.
- (2) Remove four nuts, lock washers and two U-bolts which connect the front axle propeller shaft to transfer case front axle output shaft companion flange.
- (3) Remove four nuts, lock washers and two U-bolts which connect the rear axle propeller shaft to transfer case rear axle output shaft companion flange.
- (4) Remove propeller shaft assembly.

2-87. Disassembly.

a. Splined Yoke. (Fig 2-62)

- (1) Unscrew dust cap (9) from the threaded yoke shaft and remove yoke (7) from the propeller shaft(10).
- (2) Remove dust cap, oil seal and split washer from yoke shaft.

b. Universal Joints. On the shafts with a splined slip joint, the yokes at the front and rear of the shaft must be aligned in the same horizontal plane. This is necessary to avoid vibration. The universal joints have needle bearings and are so designed that correct assembly requires no hand fitting or special tools.

- (1) Support the universal joint yoke with a 1-1/4 inch heavy duty socket and press against the opposite bearing with a 1/2-inch socket. Press the bearing cup as far as possible from the yoke.
- (2) Complete removal of bearing cup by tapping around the circumference with a small hammer, or grasp the cup in a vise and work out of the yoke.
- (3) Press the journal in the opposite direction and remove the remaining cup following the procedure outlined in steps (1) and (2) above.
- (4) Remove the trunnion from the yoke.
- (5) Remove the remaining rubber seals from yoke cavities.

2-88. Cleaning, Inspection and Repair.

- a. Clean all parts in drycleaning solvent and dry with compressed air.
- b. Inspect the splined yoke and tube for distortion, cracks, worn or damaged splines or bearing surfaces.
- c. Inspect the flanges yokes for distortion, cracks, worn or damaged bearing surfaces.
- d. Inspect trunnion journals for damaged or worn bearing surfaces.
- e. Clean and lightly oil threads of all attaching bolts and nuts.
- f. Replace parts that are unfit for further service.

2-89. Reassembly.

a. Universal Joints.

- (1) Install new seals on trunnion journals.
- (2) Install one bearing cup about one fourth way using a soft face hammer to tap the bearing cup into position. Check cup during installation to insure that it does not become misaligned in yoke.
- (3) Insert trunnion journal into the bearing cup.

- (4) Position the opposite bearing cup in yoke. Check alinement of trunnion and press the bearing cups into the yoke and over trunnion journals. Check for free movement of trunnion.
- (5) Install bearing retainer snap rings. Insure that the snap ring is properly installed.
- (6) Repeat steps (1) through (5) for the remaining two bearing cups.

b. Splined Yokes.

- (1) Install dust cap, split washer and oil seal on the splined shaft. Slide the split washer and oil seal into dust cap.
- (2) Install the yoke shaft into the propeller shaft matching the blind splines. Screw dust cap onto the yoke shaft and tighten securely.
- (3) Lubricate the splined coupling in accordance with instructions contained in the lubrication order.

2-90. Installation.

a. Front and/or Rear Propeller Shaft.

- (1) Position the propeller shaft under the vehicle with front and rear yokes in their respective locations.
- (2) Attach the propeller shaft to transfer case output shaft companion flange and install attaching U-bolts and nuts.
- (3) Connect propeller shaft to the front and/or rear axle differential pinion and install two U-bolts, four bolts and lock washer. Tighten to 12-17 lbs-ft.

b. Transfer Case to Transmission.

- (1) Position the propeller shaft between transfer case and transmission.
- (2) Install two U-bolts, four nuts and lock washers which connect the propeller shaft to the transfer case input shaft companion flange and tighten.

Section XXII. MAINTENANCE OF FRONT AXLE, FRONT SUSPENSION AND STEERING MECHANISM

2-91. General.

The front axle (fig 2-63) is a floating hypoid type. The complete unit includes the axle housing, differential with carrier, steering knuckles, universal drives, hubs, service brakes, steering linkage, springs and shock absorbers.

2-92. Maintenance and Adjustment.

- a. Lubrication Instructions. Refer to the Lubrication Order, LO 9-2320-244-12 for periodic lubrication instructions.
- b. Maintenance Instructions. Refer to the Operator s Manual, TM 9-2320-244-10, for daily maintenance instructions.

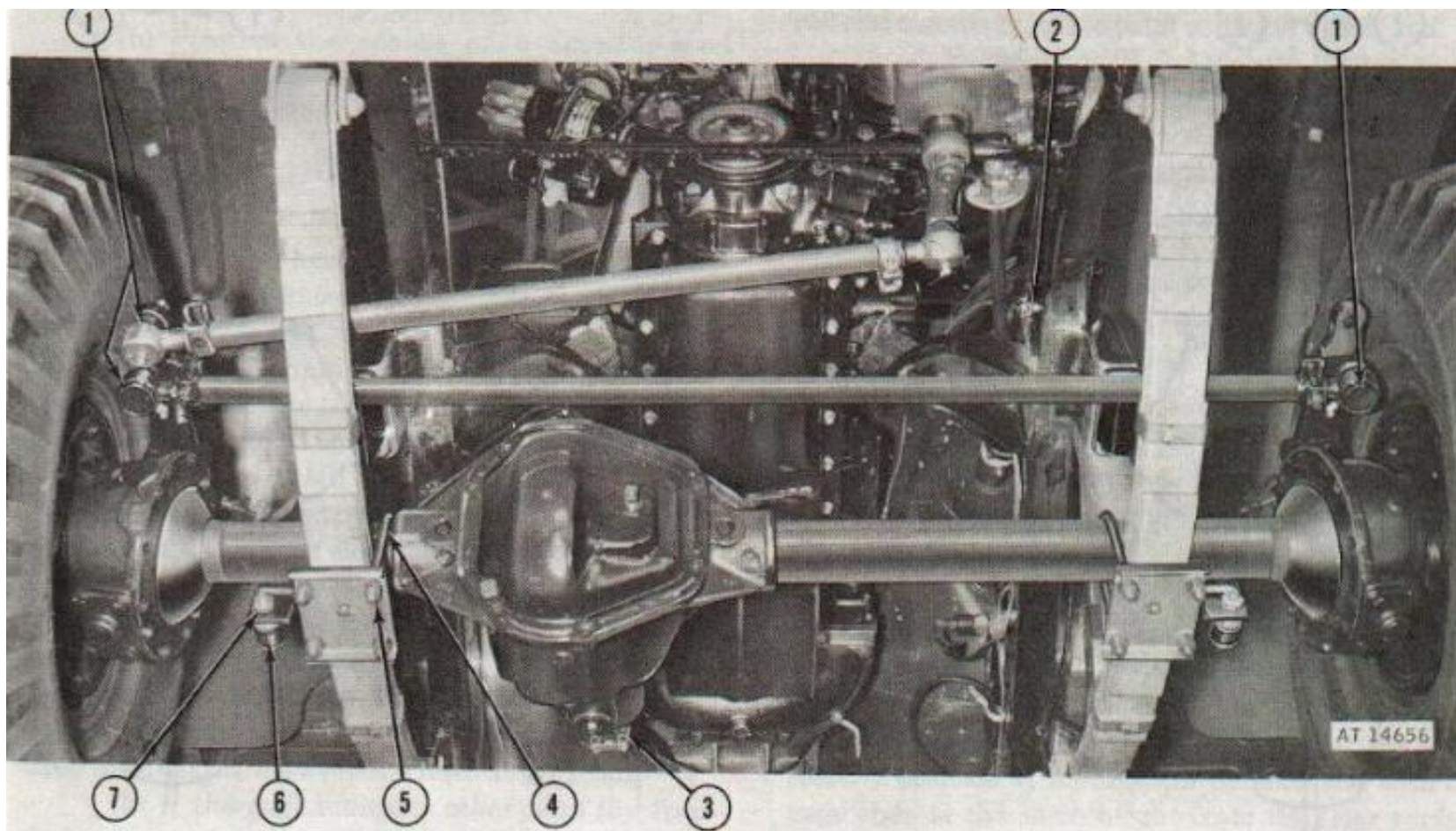

Figure 2-63. Front axle assembly.

- | | |
|------------------------------|-------------------------------|
| 1 Connecting rod | 5 Spring plates |
| 2 Brake hydraulic hose | 6 Shock absorber |
| 3 Universal companion flange | 7 Shock absorber mounting nut |
| 4 Spring clips | |

c. Wheel Alinement. Front wheel alinement affects steering of the vehicle, from a standpoint of control, ease of steering and safety, and is an important factor in the life of the tires. The items affecting front wheel alinement are caster, camber and toe-in. Caster and camber angles are built into the front axle housing and cannot be changed; however, caster and camber angles may be affected by damaged springs, frame distortion, loose bearings, bent steering linkage or a damaged axle housing. Refer to figures 2-64 and 2-65.

d. Alinement Procedures. Since incorrect toe-in may be caused by worn, damaged or incorrectly adjusted wheel bearings, damaged or loose steering linkage, make certain that these items are in good condition, correctly installed and that damaged parts are replaced before checking toe-in. Toe-in may be checked and adjusted by using either an alinement gage or a trammel bar gage. The procedures for using the two devices are given below. The trammel bar method is preferred because it provides greater accuracy than the alinement gage method. (Fig 2-66).

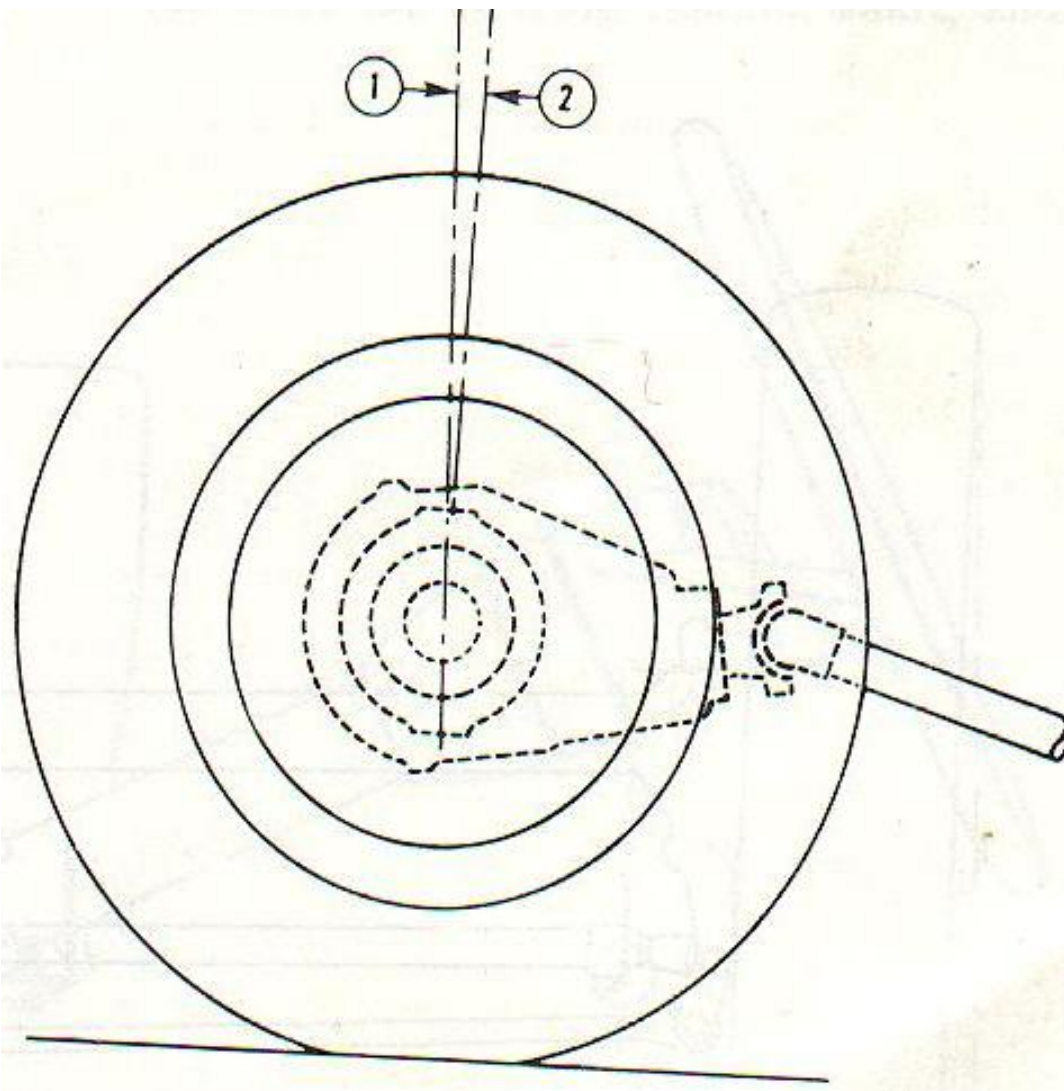

Figure 2-64. Axle Caster

- 1 Vertical line
- 2 Caster angle

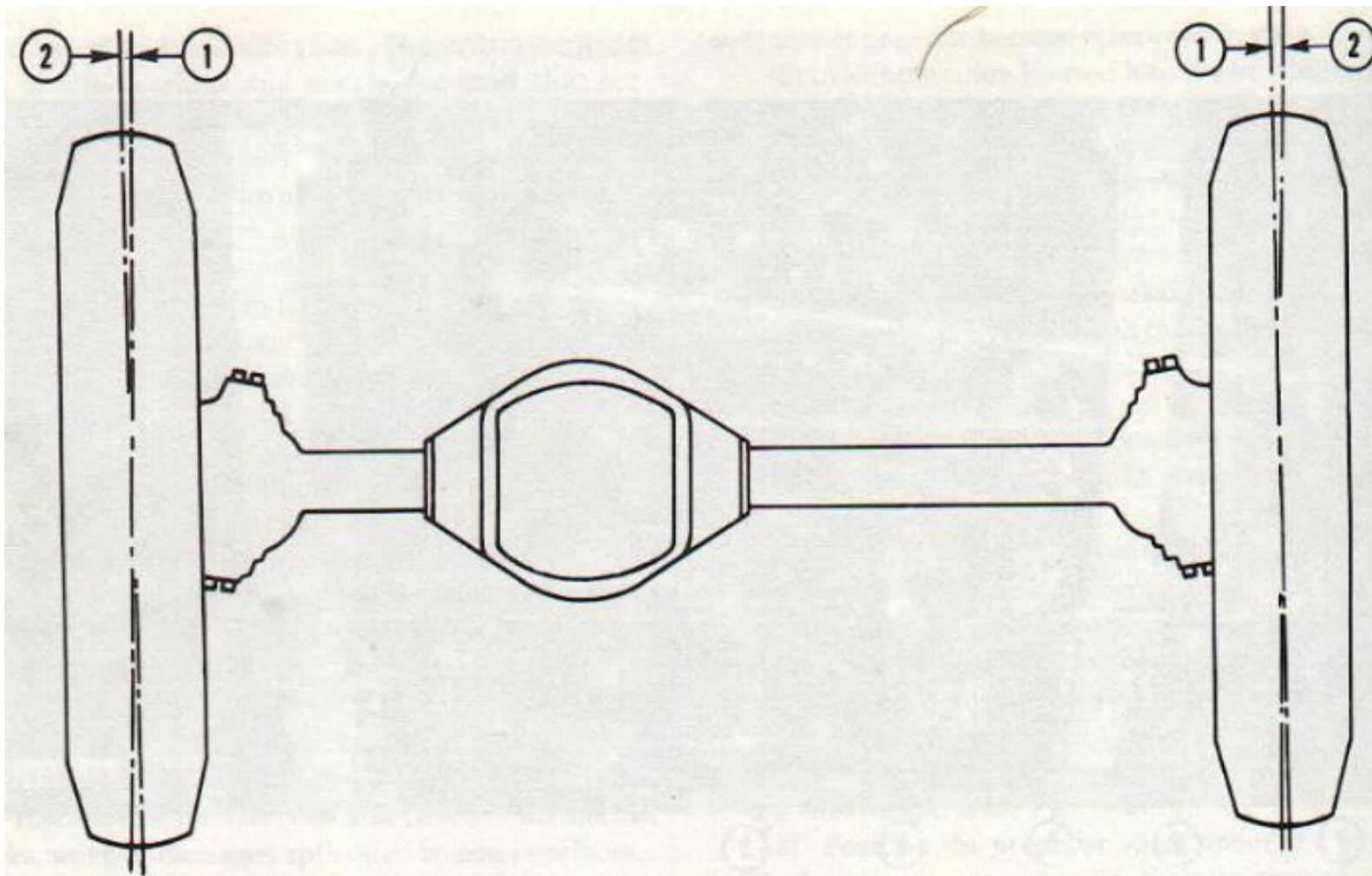

Figure 2-65. Front Wheel Camber

- 1 Vertical line
- 2 Camber angle

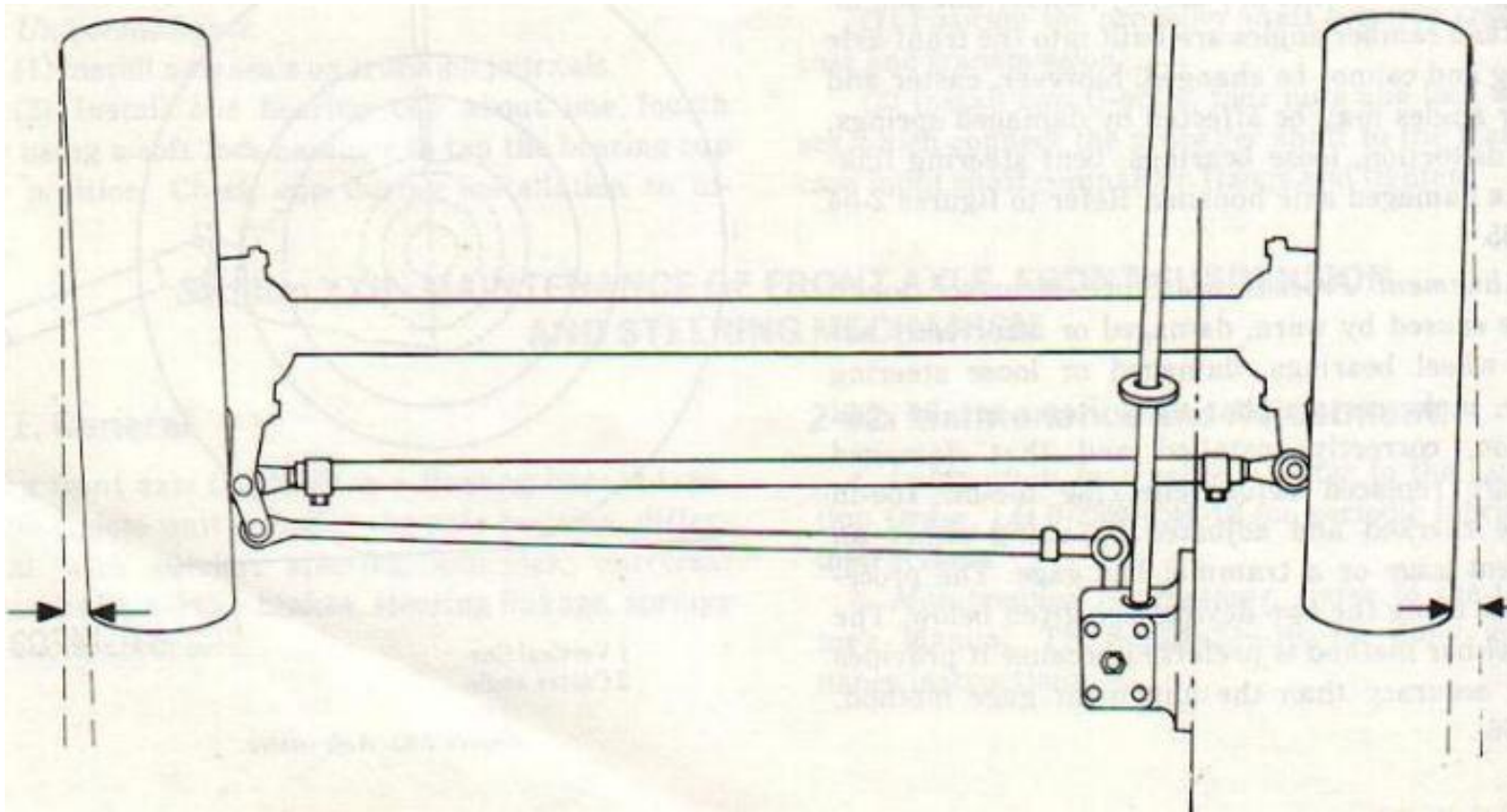

Figure 2-66 Front Wheel Toe-in (top view)

(1) Trammel bar method.

(a) Inflate tires to proper pressure.

(b) Position the vehicle on a smooth, level floor.

(c) Check wheel bearings for proper adjustment (para 2-107).

(d) Raise the front axle to free the front wheels.

(e) Place the wheels in the straight ahead position. Insure that the steering gear is on the high point before checking toe-in.

(f) Make a chalk strip around the circumference of each front tire tread at the center as the wheel is turned by hand. Then scribe a pencil line in the center of each tire tread.

(g) Adjust the trammel bar pointers so that they are at a height as close as possible to the centerline of the axle shafts. Measure the distance between the scribed lines at the front and rear of the wheels. Insure that both measurements are made at an equal distance from the floor. The distance between the lines at the rear should be $\frac{3}{32}$ to $\frac{5}{32}$ -inch greater than the distance between the lines at the front.

(h) If the gage indicates other than the specified toe-in, make adjustments as follows:

1. Loosen nuts on tie rod end clamp bolts until rod turns freely.
2. Turn the tie rod counter-clockwise to increase toe-in; clockwise to decrease toe-in.
3. When toe-in has been adjusted, rotate tie rod end clamps to locate bolts on bottom of tie rod.
4. Recheck toe-in and tighten tie rod clamp bolts securely.

(2) Alinement gage method.

(a) Inflate tires to proper pressure.

(b) Check wheel bearings for proper adjustment (para 2-107).

(c) Position the vehicle on a smooth, level floor with the wheels in a straight ahead position. With the wheels in this position, insure that the steering gear is on the high point before checking toe-in.

NOTE

It is important to get the gage at a height as close as possible to that of the axle shaft centerline.

(d) Place the wheel alinement toe-in gage between the wheels at the rear of the front axle and immediately below the front propeller shaft.

(e) Place the gage ends against the tire side-walls at equal distances from the floor surface.

(f) Set the gage at zero.

(g) Remove the gage and place it at the same relative position at the front of the axle and with the gage ends at the same height from the floor surface as at the rear. The gage will indicate the amount of toe-in or toe-out. The correct toe-in is $\frac{3}{32}$ to $\frac{5}{32}$ -inch.

(3) Steering column adjustments. (Fig 2-67)

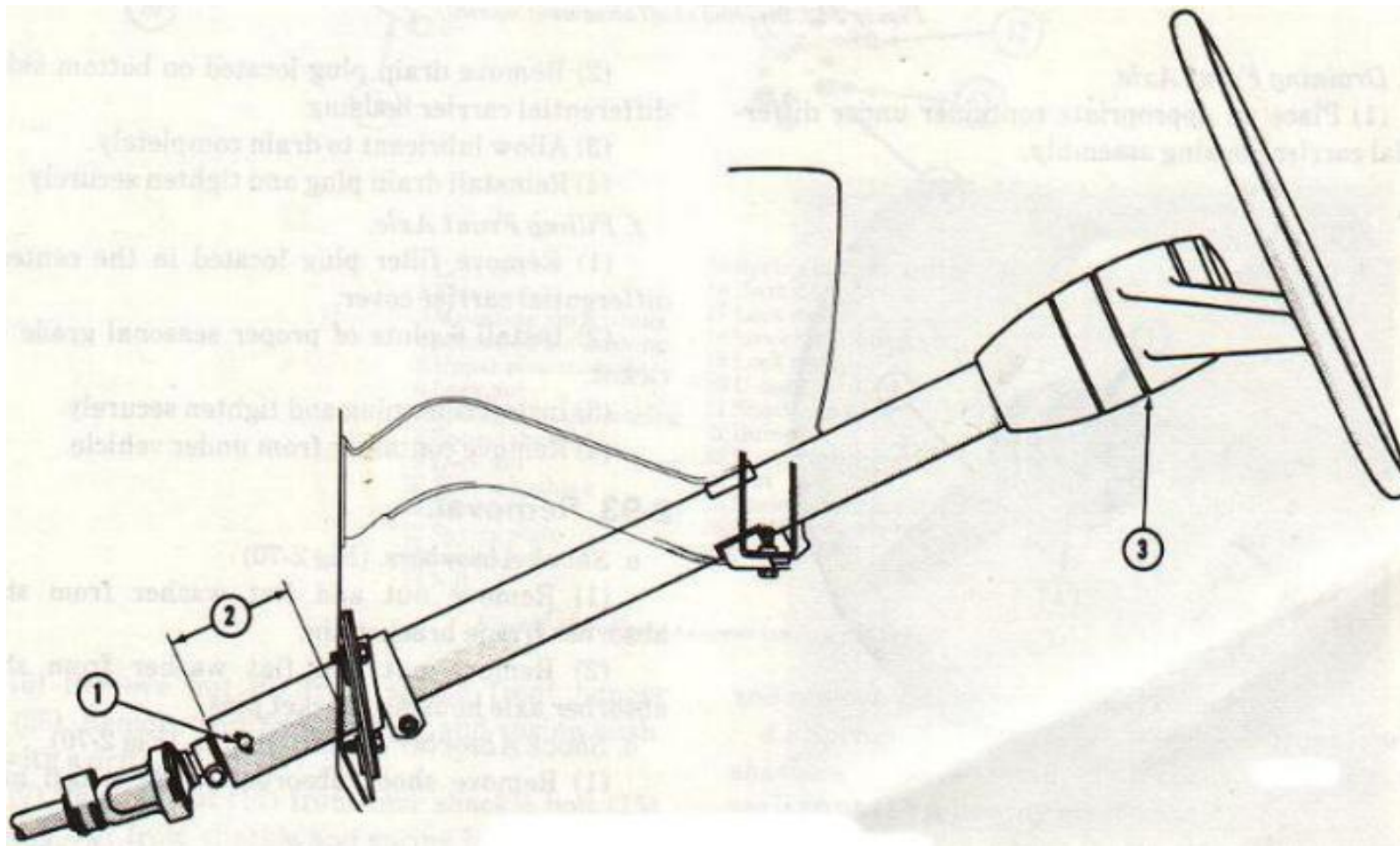

Figure 2.67. Steering column adjustments.

- 1 Lower bearing adjusting screw
- 2 Measurement U-joint coupling position
- 3 Steering wheel to steering column gap

(a) With the steering column, shaft, and U-joint coupling installed, and the front wheels set straight ahead, check position of mark on worm shaft designating steering gear high point. This mark should be at the top side of the shaft at 12 o'clock position and lined up with the mark in the flexible coupling lower clamp (fig 2-68). If this alignment is correct, check the alignment of mark on upper end of lower steering shaft and saw cut in U-joint coupling. With the steering wheel installed be certain alignment mark on steering shaft matches with mark on steering wheel hub as in figure 2-69.

(b) To insure proper U-joint coupling positioning, measure along side of the steering column and check dimension from bottom of column to the firewall face. The correct dimension is 3-15/16-inch. Should adjustment be necessary, loosen steering column clamps and move column up or down, until the proper measurement is obtained. Secure steering column by tightening all clamps.

(c) Check the gap between the upper steering column housing and the steering wheel hub. To adjust gap, loosen the steering column shaft clamp (located above the U-joint coupling) and pull the steering column shaft upward. The proper clearance is 1/16-inch to 3/32-inch. Tighten clamp when the proper gap is obtained.

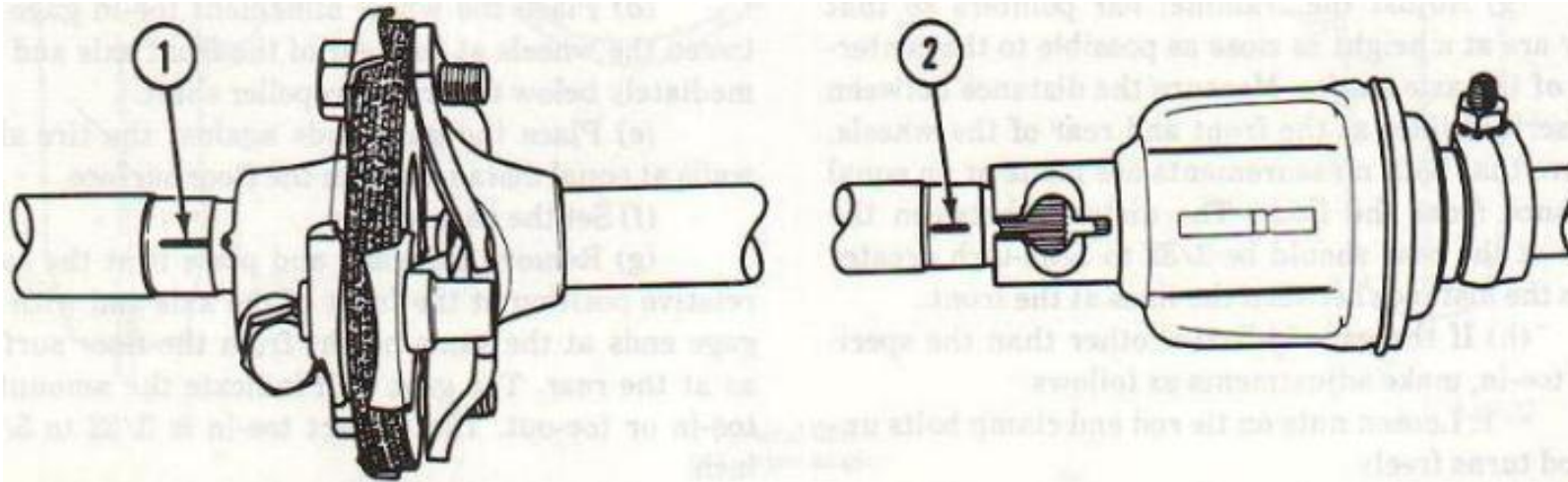

Figure 2-68. Steering shaft alignment marks

- 1 Flexible coupling to steering gear shaft
- 2 Lower shaft and flange to U-joint coupling

d. Draining Front Axle.

- (1) Place an appropriate container under differential carrier housing assembly.
- (2) Remove drain plug located on bottom side of differential carrier housing.
- (3) Allow lubricant to drain completely.
- (4) Reinstall drain plug and tighten securely.

e. Filling Front Axle.

- (1) Remove filler plug located in the center of differential carrier cover.
- (2) Install 6 pints of proper seasonal grade lubricant.
- (3) Install filler plug and tighten securely.
- (4) Remove container from under vehicle.

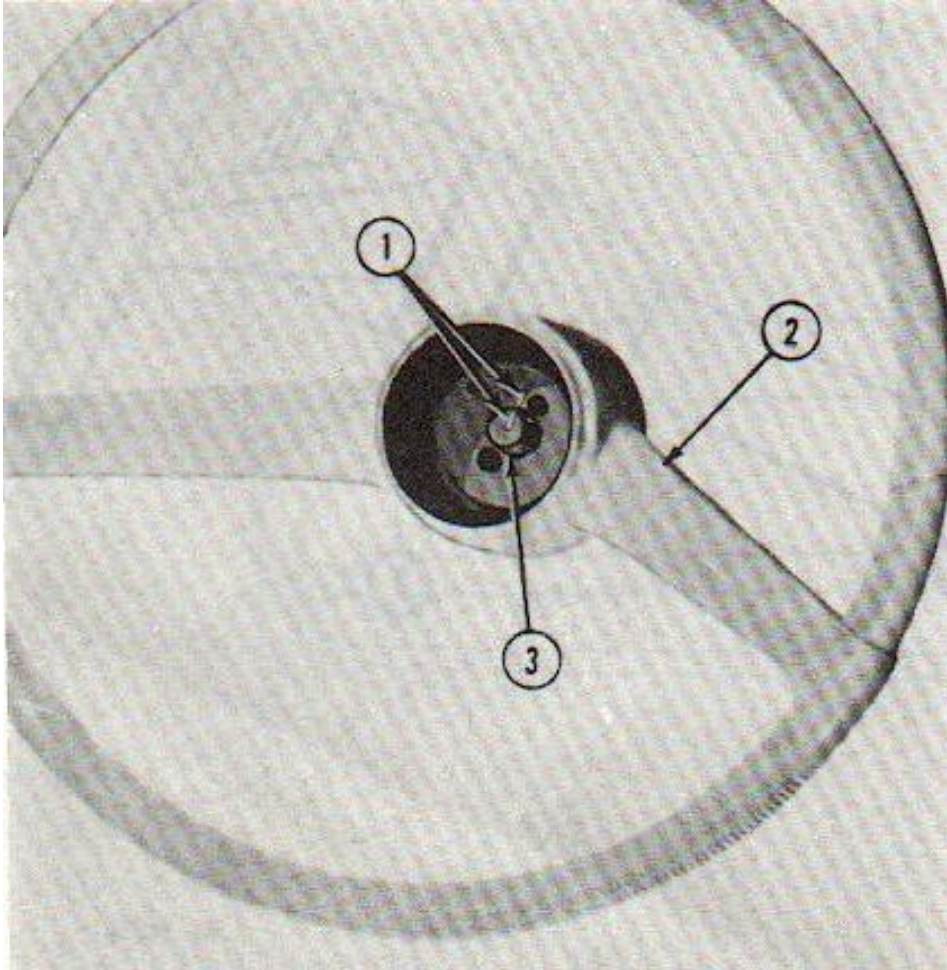

Figure 2.69. Steering wheel and shaft alignment.

- 1 Alinement marks
- 2 Steering wheel
- 3 Steering shaft

2-93. Removal.

a. Shock Absorbers. (Fig 2-70)

- (1) Remove nut and flat washer from shock absorber frame bracket pin.

(2) Remove nut and flat washer from shock absorber axle housing bracket pins.

b. Shock Absorber Mounting Pins. (Fig 2-70)

(1) Remove shock absorber as described in (a) above.

(2) Remove nut, which secures shock absorber mounting pin to axle housing bracket.

(3) Remove shock absorber mounting pins.

c. Springs. (Fig 2-70)

(1) Place transmission in gear, set hand brake and place wheel chocks at front and rear of rear wheels.

(2) Raise front of vehicle and place jack stands under each frame side rail under cab area.

(3) Support axle with a floor jack so that tension and compression are relieved from spring.

(4) Remove four U-bolt nuts and lock washers.

(5) Remove U-bolt spring plate and U-bolts.

NOTE

If left and right springs are being removed, do not intermix left and right spring attaching components.

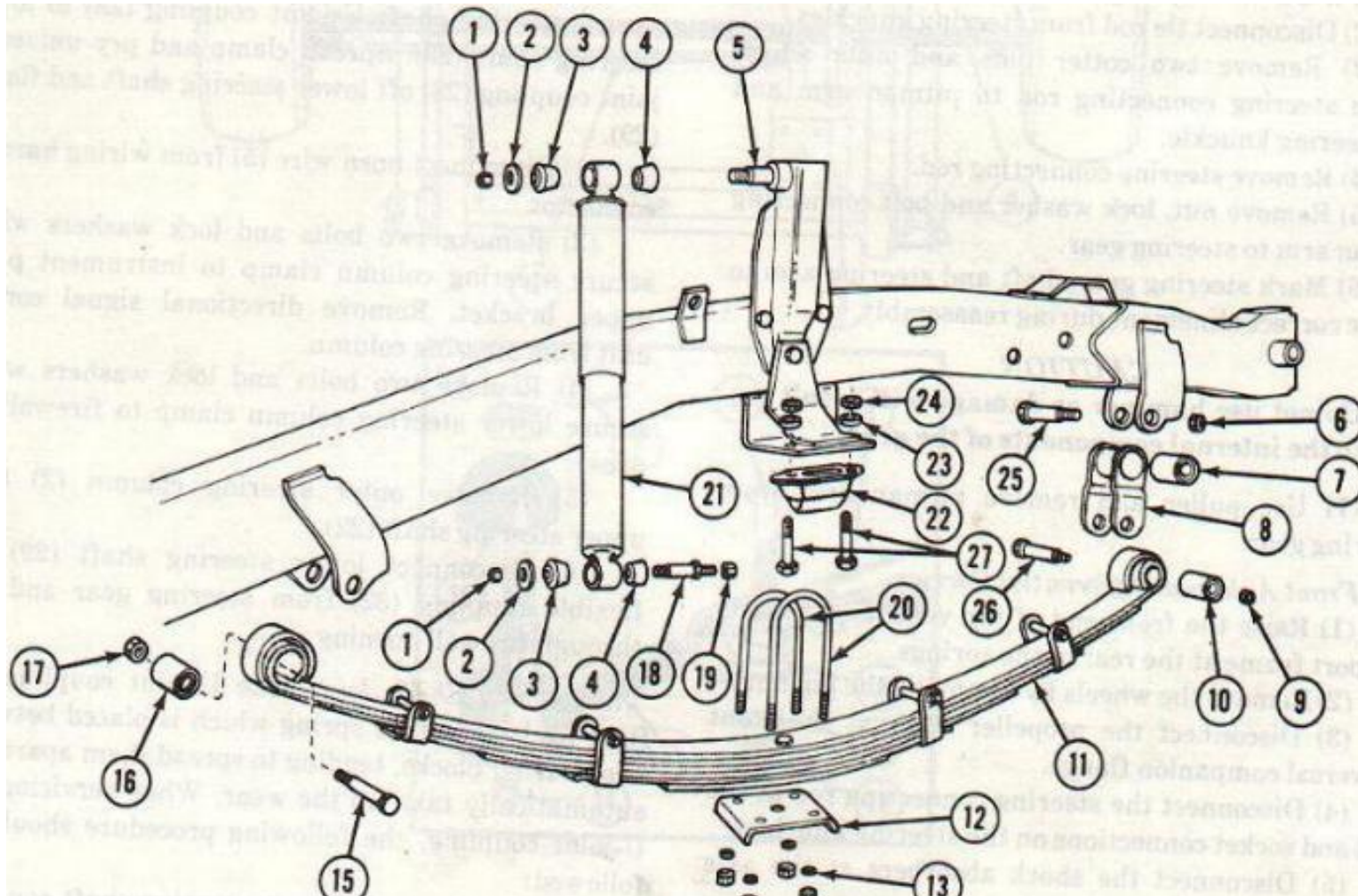

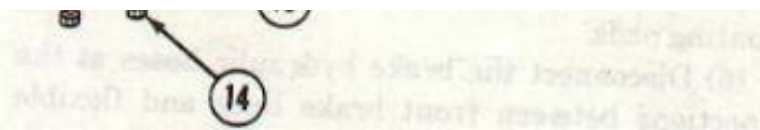

Figure 2-70. Front suspension Components.

1 Lock nut	10 Spring bushing	19 Lock nut
2 Flat washer	11 Spring	20 U-bolt
3 Mounting pin bushing	12 Spring plate	21 Shock absorber
4 Mounting pin bushing	13 Lock washer	22 Bumper
5 Upper mounting pin	14 Nut	23 Lock washer
6 Lock nut	15 Spring bushing bolt	24 Nut
7 Spring shackle bushing	16 Bushing	25 Spring shackle bolt
8 Spring shackle	17 Lock nut	26 Spring shackle bolt
9 Lock nut	18 Lower mounting pin	27 Bolt

(6) Remove nut (6) from spring front hanger bolt (25). Remove bolt from hanger and spring bushing with a drift.

(7) Remove nut (17) from rear shackle bolt (15). Remove bolt from shackle and spring bushing with a drift.

(8) Remove spring from vehicle.

(9) Remove bolts (27), nuts (24), lock washers (23) and remove spring bumper (22) from frame.

d. Spring Shackle. (Fig. 2-70) The front spring shackles can be removed without removing the springs by the following procedure:

(1) Place jack under frame side rail in order to relieve the load on spring.

(2) Remove the shackle bolt by removing locknut.

(3) Remove the locknut and flat washer from the spring hanger.

(4) Swing the spring shackle up so it is clear of the spring. Pull the spring shackle off the spring hanger.

e. Steering Linkage. (Fig 2-71)

(1) Remove two cotter pins and nuts connecting tie rod to left and right steering knuckle arms.

(2) Disconnect tie rod from steering knuckles.

(3) Remove two cotter pins and nuts which secure steering connecting rod to pitman arm and left steering knuckle.

(4) Remove steering connecting rod.

(5) Remove nut, lock washer and bolt connecting pitman arm to steering gear.

(6) Mark steering gear shaft and steering arm to insure correct alignment during reassembly.

CAUTION

Do not use hammer or damage will result to the internal components of the gear.

(7) Use puller and remove pitman arm from steering gear.

f Front Axle and Differential Carrier.

(1) Raise the front end of the vehicle and safety support frame at the rear of the springs.

(2) Remove the wheels by removing the lug nuts.

(3) Disconnect the propeller shaft at the front universal companion flange.

(4) Disconnect the steering connecting rod at the ball and socket connections on the steering knuckles.

- (5) Disconnect the shock absorbers at the axle mounting pads.
- (6) Disconnect the brake hydraulic hoses at the connections between front brake lines and flexible hoses. Disconnect the breather hose.
- (7) Support the axle assembly on a jack, ready for removal.
- (8) Remove the nuts from the spring clips and remove the spring clip plates.
- (9) Drain lubricant.
- (10) Remove ten bolts and lock washers which secure differential carrier cover to axle housing.
- (11) Remove differential carrier cover and gasket; discard gasket.

g. Steering Wheel.

- (1) Remove horn button by pulling straight away from steering wheel hub.
- (2) Remove three screws which secure horn button, contact flange, horn switch and horn contact spring to steering wheel. Remove contact flange, horn switch and horn contact spring.
- (3) Remove hex head nut and lock washer which secure steering wheel to steering shaft.
- (4) Install steering wheel puller using tool FSN 5120-168-2280. (Fig 2-69)
- (5) Tighten puller screw until steering wheel dislodges from steering shaft.
- (6) Remove steering wheel puller from steering wheel and remove steering wheel from steering shaft.

h. Steering Column. (Fig 2-73)

- (1) Remove nut, lock washer and bolt which secure steering shaft U-joint coupling (28) to lower steering shaft (29). Spread clamp and pry universal joint coupling (28) off lower steering shaft and flange (29).
- (2) Disconnect horn wire (5) from wiring harness connector.
- (3) Remove two bolts and lock washers which secure steering column clamp to instrument panel upper bracket. Remove directional signal control unit from steering column.
- (4) Remove two bolts and lock washers which secure lower steering column clamp to firewall toe panel.
- (5) Remove outer steering column (2) from upper steering shaft (22).
- (6) Disconnect lower steering shaft (29) and flexible coupling (32) from steering gear and pull through firewall opening.

i. Steering Shaft Joint. The U-joint coupling (28 fig 2-73) has a single spring which is placed between two bearing blocks, tending to spread them apart and automatically take up the wear. When servicing the U-joint coupling, the following procedure should be followed:

- (1) Disconnect the lower steering shaft coupling at the steering gear by removing the two nuts, bolts and lock washers.
- (2) Loosen clamp holding U-joint coupling cover to lower shaft and remove U-joint coupling cover.
- (3) Remove spring clip from cover and carefully remove cover from steering shaft. Use caution to avoid loss of small parts inside cover.

NOTE

Use extreme caution to prevent damage to bearing surfaces of the pin.

- (4) Remove steering shaft pivot pin bearing blocks and wave washers.
- (5) Carefully inspect all parts for signs of wear. If pivot pin in steering shaft is not serviceable, steering shaft must be removed and replaced with a new steering shaft-pin assembly.

j. Steering Gear.

- (1) Remove alien head clamping screw which secures the flexible coupling to the steering gear shaft.
- (2) Disconnect steering connecting rod from the steering arm.



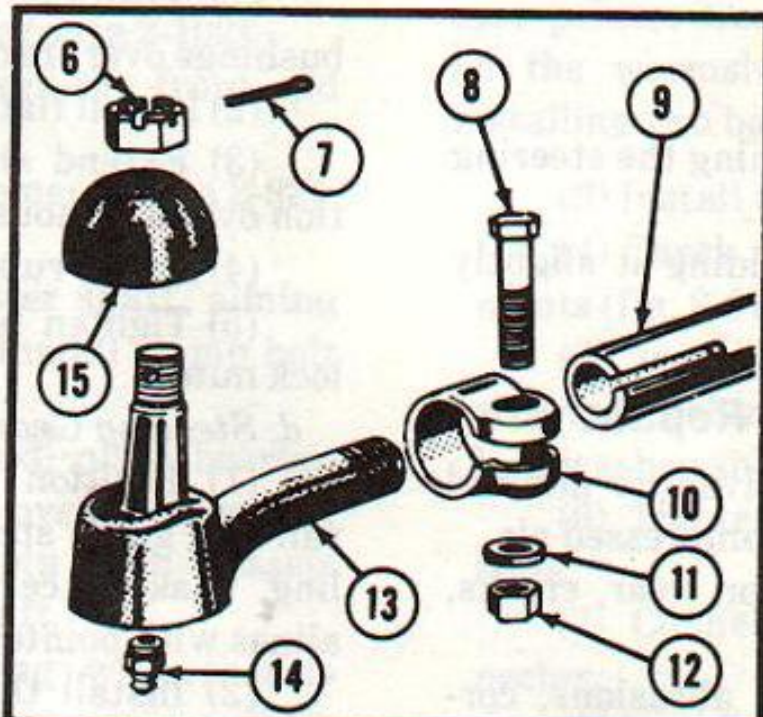
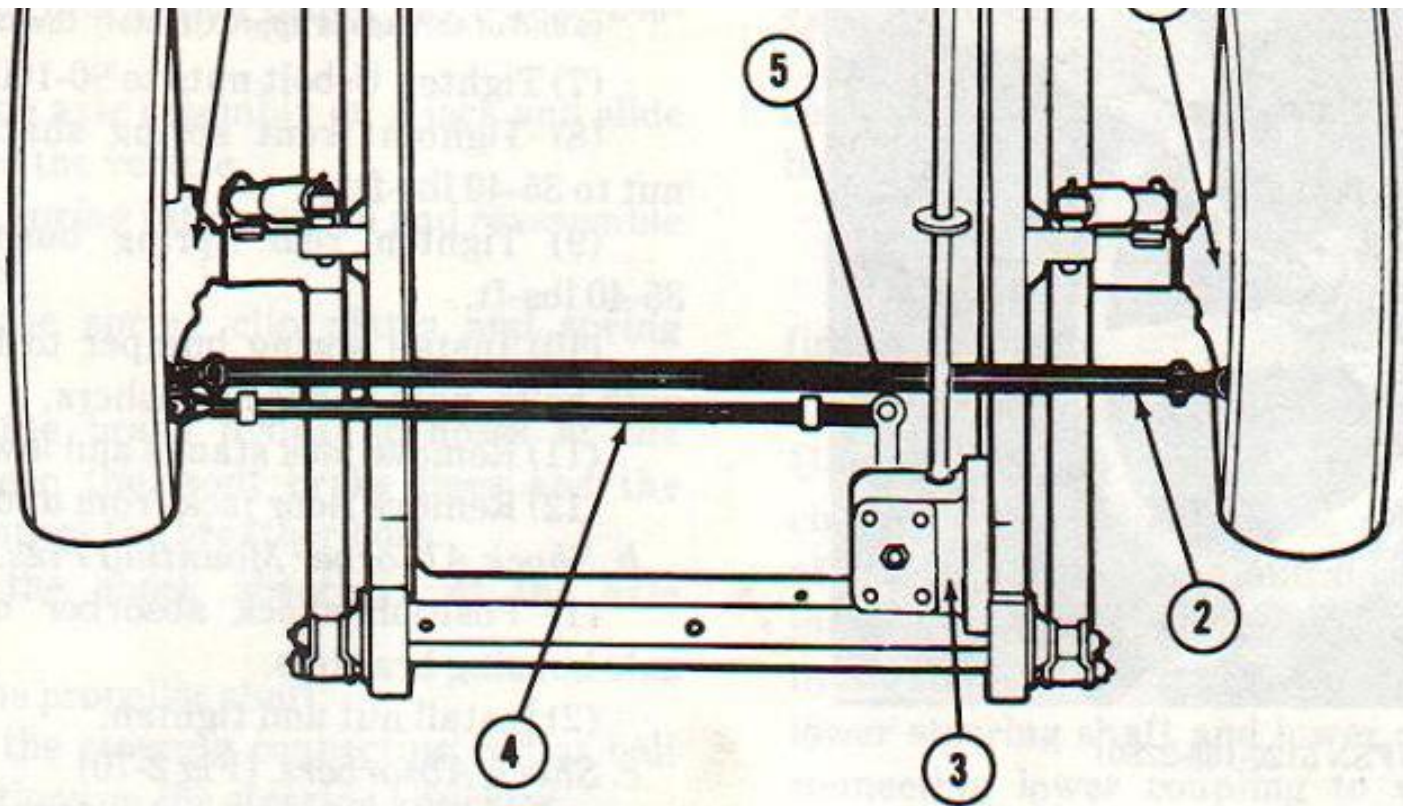

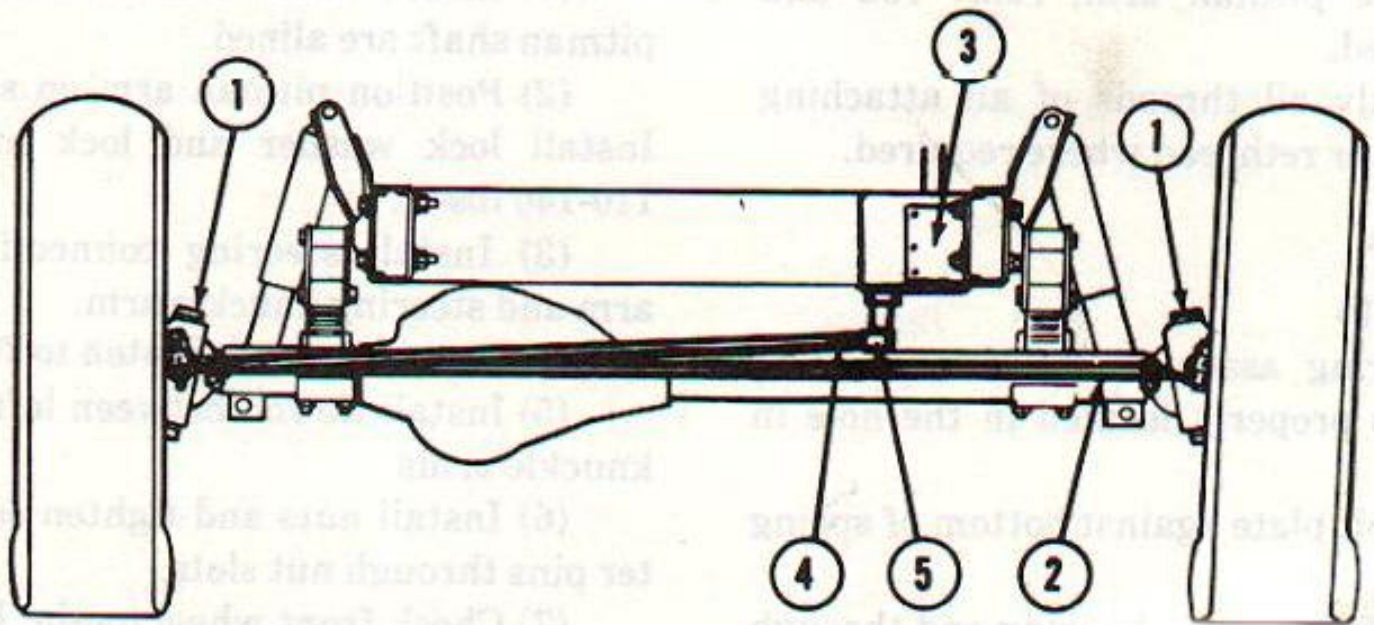

FIGURE 2-71. Steering Linkage

1 Steering knuckle	9 Tie rod tube
2 Tie rod	10 Clamp
3 Steering gear	11 Lockwasher
4 Connecting steering rod	12 Nut
5 Pitman arm	13 Ball joint
6 Castle nut	14 Lubrication fitting
7 Cotter pin	15 Rubber seal
8 Nut	

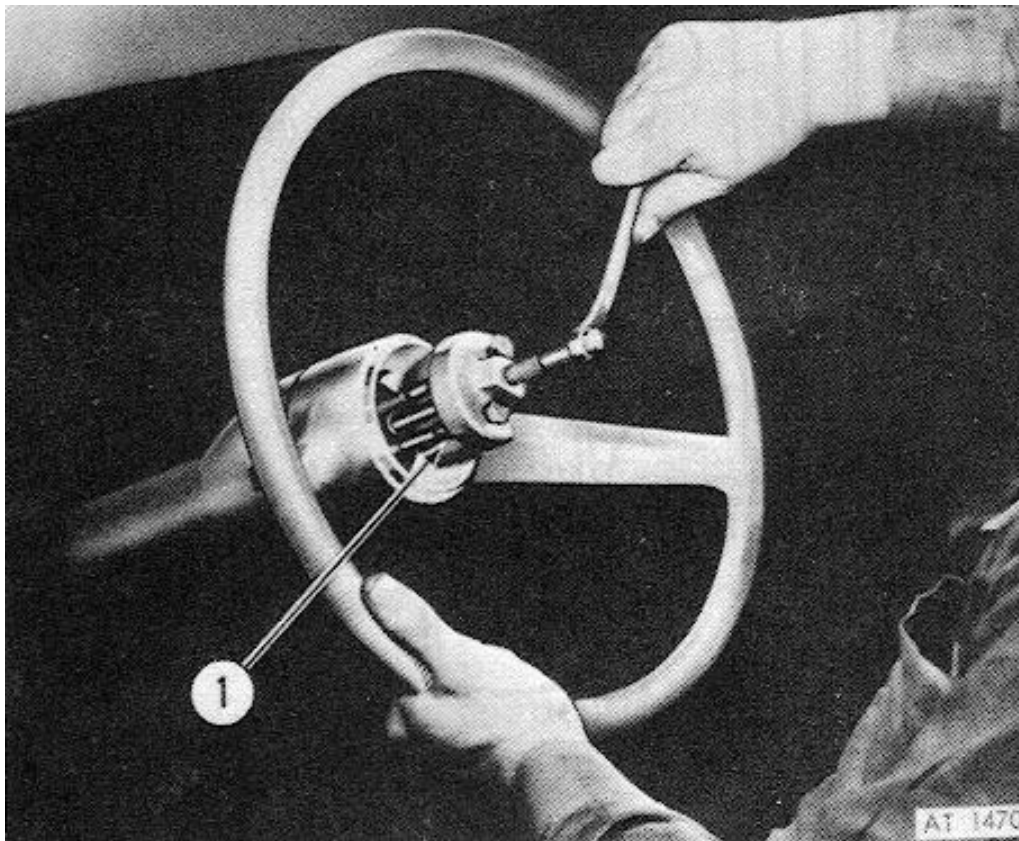

Figure 2-72. Steering wheel removal

1 Puller tool (FSN 5120-168-2280)

- (3) Remove the three bolts attaching the steering gear to frame.
- (4) Remove steering gear by sliding it slightly forward and to the right.

2-94. Cleaning, Inspection and Repair.

- a. Clean all parts in drycleaning solvent or mineral spirits base paint thinner. Dry with compressed air.
- b. Inspect steering gear linkage for wear, cracks, distortion or damaged threads.
- c. Inspect bumpers and seals for abrasions, corrosion, wear or deterioration.
- d. Clean axle housing and cover mating surfaces of all sealant and gasket materiel. If scraping is required, do not nick or gouge surfaces.
- e. Remove minor abrasions or corrosion with crocus cloth. Replace pitman arm, relay rod and control rod, if damaged.
- f. Clean and lightly oil threads of all attaching bolts and nuts. Retap or rethread where required.

2-95. Installation.

a. Springs. (Fig 2-70)

- (1) Position spring assembly so that head of spring center bolt is properly located in the hole in axle spring seat.

- (2) Position U-bolt plate against bottom of spring assembly.
- (3) Install U-bolts over axle housing and through holes in spring plate.
- (4) Install four lock washers and nuts on U-bolts. Do not tighten.
- (5) Position spring shackle in front hanger. Install spring bushing bolt and nut. Do not tighten.
- (6) Position rear spring eye in spring hanger and install spring bushing, bolt, and nut. Do not tighten. Tighten U-bolt nuts evenly so that the distance from nut to end of threads is approximately the same.
- (7) Tighten U-bolt nuts to 90-100 lbs-ft.
- (8) Tighten front spring shackle bushing bolt nut to 35-40 lbs-ft.
- (9) Tighten rear spring bushing bolt nut to 35-40 lbs-ft.
- (10) Install spring bumper to frame and secure with bolts, nuts and lock washers.
- (11) Remove jack stands and lower vehicle to floor.
- (12) Remove floor jack from under vehicle.

b. Shock Absorber Mounting Pins. (Fig 2-70)

- (1) Position shock absorber mounting pins in axle housing brackets.
- (2) Install nut and tighten.

c. Shock Absorbers. (Fig 2-70)

- (1) Position large end of shock absorber and bushings over frame bracket mounting pin.
- (2) Install flat washer and nut. Do not tighten.
- (3) Extend shock absorber as required to position over axle housing lower mounting pin.
- (4) Install rubber bushings, flat washer and nut.
- (5) Tighten both upper and lower mounting pin lock nuts.

d. Steering Gear. (Fig 2-68)

- (1) Position steering gear against frame side rail and guide steering gear shaft into flexible coupling, making certain line mark on steering shaft aligns with pointer on flexible coupling.
- (2) Install three bolts and secure steering gear to frame side rail. Tighten bolts 55 to 75 lbs-ft.
- (3) Install allen head screw securing flexible coupling to steering gear shaft. Tighten screws 18 to 30 lbs-ft.

e. Steering Linkage. (Fig 2-71)

- (1) Insure that marks on steering gear arm and pitman shaft are aligned.
- (2) Position pitman arm on steering gear shaft. Install lock washer and lock nut and tighten to 110-140 lbs-ft.
- (3) Install steering connecting rod in pitman arm and steering knuckle arm.
- (4) Install nut and tighten to 70-90 lbs-ft.
- (5) Install tie rod between left and right steering knuckle arms.
- (6) Install nuts and tighten securely. Install cotter pins through nut slots.
- (7) Check front wheel toe-in. Reset as outlined in paragraph 2-92d.

f. Front Axle and Differential Carrier.

- (1) Apply sealant liberally to new differential carrier cover gasket and position on axle housing.
- (2) Position differential carrier cover and install ten attaching bolts and lock washers. Tighten securely.
- (3) Fill axle with proper seasonal grade lubricant per instructions in lubrication order, LO 9-2320-244-12.
- (4) Support the axle assembly on a jack and slide into position under the vehicle.
- (5) Swing the spring into position and reassemble the spring shackles,
- (6) Replace the spring clip plates and spring clips.
- (7) Connect the brake hydraulic hoses at the connections between the front brake lines and the flexible hoses. Connect the breather hose.

- (8) Connect the shock absorbers at the axle mounting pads.
- (9) Connect the propeller shaft.
- (10) Connect the steering connecting rod at ball and socket connections on the steering knuckles.
- (11) Adjust and bleed the brakes (para 2-102).
- (12) Remove supports and lower the front end of the vehicle.
- (13) Check front end wheel alinement (para 2-92).

g. Steering Shaft Joint. (Fig 2-68)

- (1) Install coupling over on lower shaft, alining slot in clamp with mark on shaft. Install clamp bolt and tighten,
- (2) With steering shaft installed, place bearing blocks with wave washers in place over each end of pivot pin after first lubricating pin with chassis grease. Place retainer over end of shaft.
- (3) Lubricate inside of housing with chassis grease and carefully position over pivot pin.
- (4) Position retainer and bolt in housing and install spring clip.
- (5) Connect lower shaft and flange to the flexible coupling attached to the steering gear. Install two bolts and tighten.

h. Steering Column. (Fig 2-73)

- (1) Insert steering column and shaft through firewall opening.
- (2) Install upper end of lower shaft to the upper U-joint coupling. The split in the upper coupling clamp must be aimed to the mark on the upper end of the lower shaft to maintain steering wheel centering with steering gear hi-point. Secure attachment by tightening the upper coupling clamp bolt. Install lower steering shaft and lower coupling assembly by connecting lower coupling to wormshaft, with the cast pointer on the coupling alined with the mark on the wormshaft (fig. 2-68). Secure coupling by installing two bolts, nuts and lock washers.
- (3) Install the lower toe pan cover plate bolts.
- (4) Check steering column alinement and adjustments (fig. 2-67).
- (5) Install directional signal control unit and steering column upper clamp. Install attaching lock washer and bolts.
- (6) Tighten upper bracket to instrument panel bolts.
- (7) Connect horn wire to wiring harness connector.
- (8) Install steering wheel as outlined in (i) below.

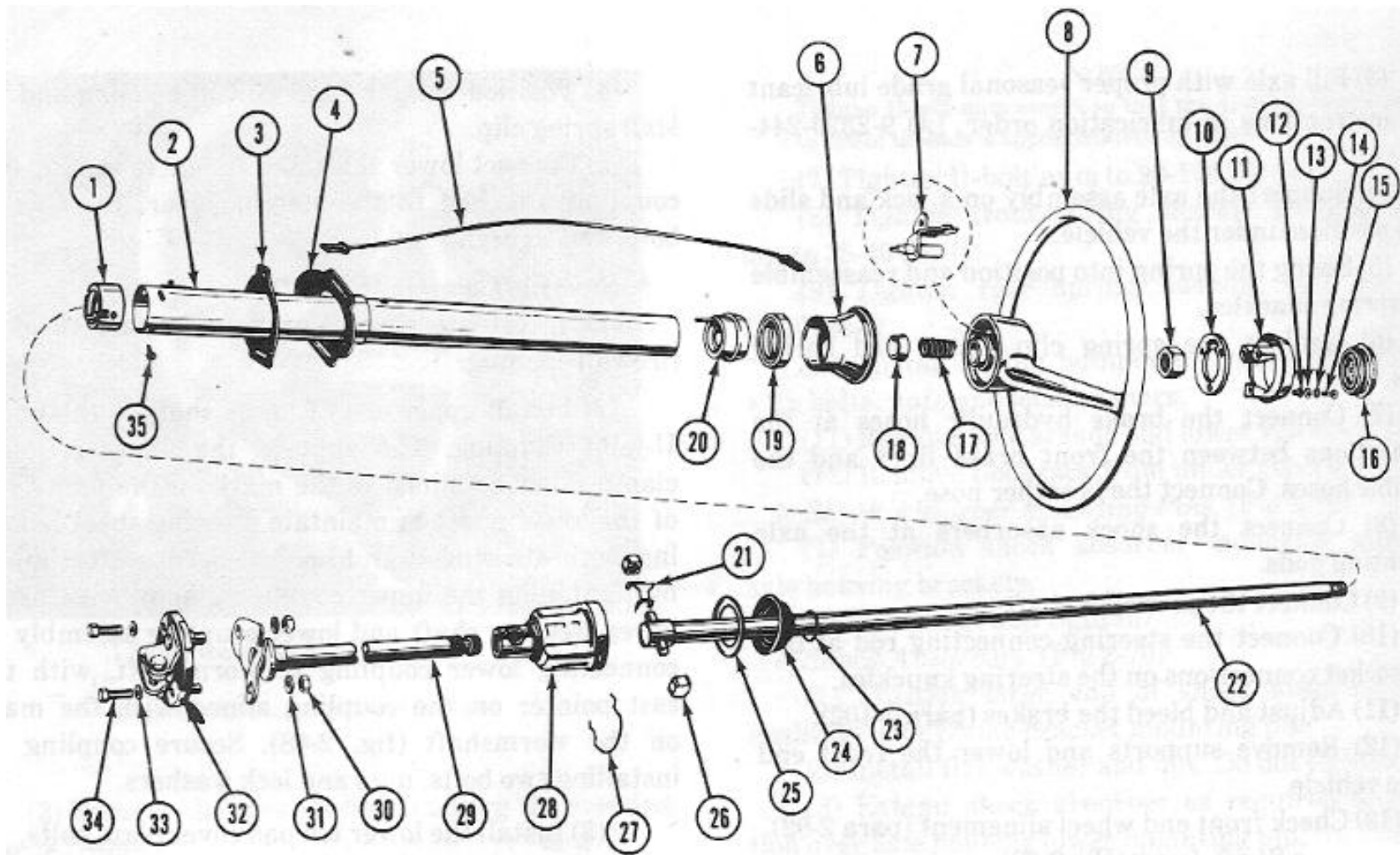

Figure 2-73. Steering column.

1 Lower bearing	10 Horn switch	19 Seal	28 U-joint coupling
2 Outer steering column	11 Horn button contact flange	20 Upper bearing and horn connector	29 Low steering shaft and flange
3 Gasket	12 Horn switch spacer	21 Spring	30 Nut
4 Support and clamp	13 Flat washer	22 Upper steering shaft	31 Lock washer
5 Horn wire	14 Lock washer	23 Spring	32 Flexible coupling
6 Housing	15 Screw	24 Boot	33 Lock washer
7 Horn connector	16 Horn button	25 Retainer	34 Cap screw

8 Steering wheel	17 Spring	26 Bearing	35 Screw and lock washer
9 Nut	18 Upper bearing collar	27 Snap ring	

i. Steering Column.

- (1) With front wheels in straight ahead position, alinement mark on steering shaft must be a 12 o clock position.
- (2) Position steering wheel on steering shaft. Notch on steering hub must line up with alinement mark on steering shaft. (Fig 2-69)
- (3) Install washer and nut and tighten to 32-38 lbs-ft.
- (4) Position horn contact flange, horn switch and horn button contact spring on steering wheel hub.
- (5) Install three attaching screws and tighten securely.
- (6) Install horn button by pushing straight down into horn button receiver.
- (7) Check horn operation.

Section XXIII. MAINTENANCE OF REAR AXLE AND REAR SUSPENSION

2-96. General.

The single speed rear axle assembly is of the full floating hypoid type. The carrier-type axle assembly is composed of a carrier section, tubes and axle shafts. Power is transmitted from the transfer case to the rear axle differential by a propeller shaft. Venting of the axle housing is provided through a rubber tube to the engine compartment.

NOTE

The axle model number is cast into the housing and a metal tag under two of the differential housing cover screws is stamped to identify the axle ratio. (Fig 2-74)

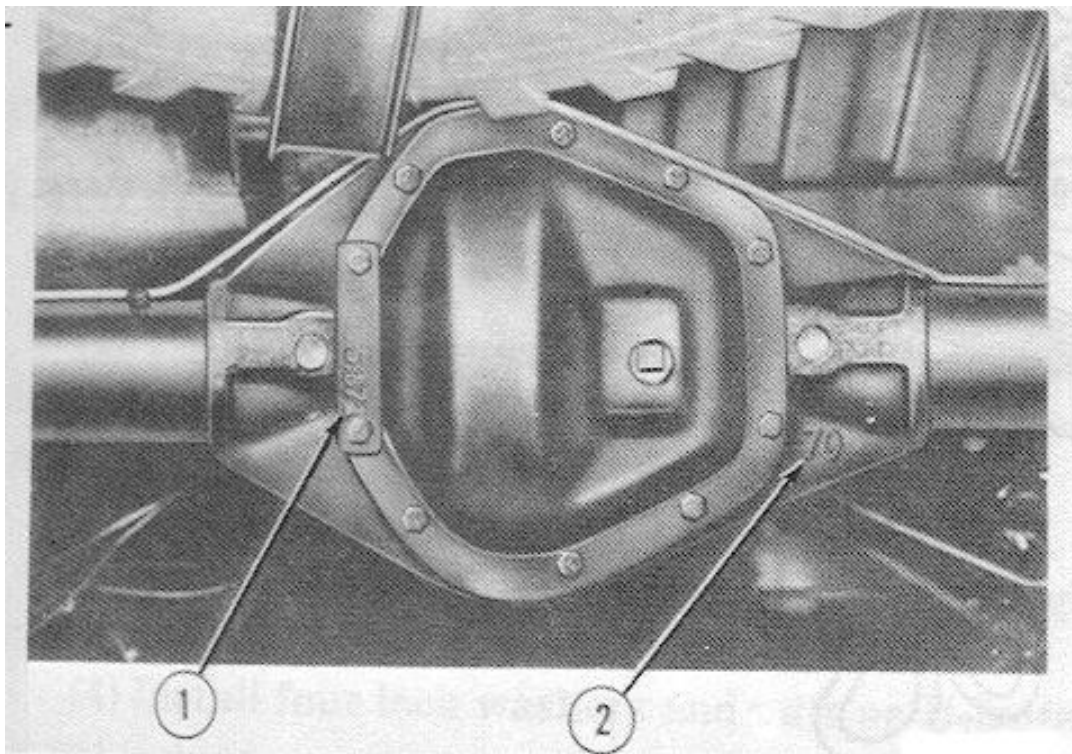

Figure 2.74. Axle model and ratio identification.

- 1 Ratio
- 2 Axle model

2-97. Maintenance and Adjustment.

a. General. Refer to the Lubrication Order, LO 9-2320-244-12, for periodic lubrication instructions and prescribed lubricant for all temperature ranges.

b. Draining Rear Axle.

- (1) Place an appropriate container under the differential carrier assembly.
- (2) Remove drain plug located in the bottom of the axle housing.
- (3) Allow lubricant to drain completely.
- (4) Reinstall drain plug and tighten securely.

c. Filling Rear Axle.

- (1) Remove filler plug located in the right side of differential carrier housing.
- (2) Install 6 pints of proper seasonal grade lubricant.
- (3) Install filler plug and tighten to 25-35 lbs-ft.
- (4) Remove container from under differential carrier assembly.

2-98. Removal.

a. Shock Absorbers. (Fig 2-75)

- (1) Remove nut and flat washer which secure shock absorber and bushings to frame bracket mounting pin.
- (2) Remove nut and flat washer which secure shock absorber and bushings to axle housing bracket mounting pin.
- (3) Remove shock absorber and bushings from frame bracket and axle housing mounting pins.

b. Shock Absorber Lower Mounting Pins. (Fig 2-75)

- (1) Remove upper end of shock absorber as described in (a) above.
- (2) Remove nut and mounting pin to axle housing bracket.
- (3) Remove lower shock absorber mounting pin from bracket.

c. Springs. (Fig 2-75)

- (1) Raise rear of vehicle and place jack stands under each frame side rail just forward of spring front hangers.
- (2) Support axle with floor jack so that tension and compression are relieved from spring.
- (3) Remove four U-bolt nuts and lock washers.
- (4) Remove U-bolt anchor plate and U-bolts.
- (5) Remove nut and flat washer from spring front hanger bolt.
- (6) Remove nut and washer from rear shackle bolt. Remove bolt from shackle and spring bushing using a drift.
- (7) Remove spring from vehicle.
- (8) Remove bolts, nuts, lock washers and remove spring bumper from frame.

8 Spring bushing	18 U-bolt	28 Lock nut
9 Flat washer	19 Lower mounting pin	29 Spring plate
10 Lock nut	20 Lower mounting pin bushing	30 Spacer

d. Spring Shackle. Rear spring shackle removal should be performed with the spring removed from the vehicle following the procedure given in paragraph 2-93d.

e. Axle Shafts.

- (1) Remove eight nuts and lock washers which secure axle shaft to hub assembly.
- (2) Remove lifting bracket, spacers and split lock washers.

CAUTION

Do not use chisels or wedges to loosen axle shaft from hub as this will damage hub and shaft.

- (3) Tap axle shaft flange to loosen shaft and remove from drive unit and housing.
- (4) Remove and discard gasket.

f Rear Axle and Differential Carrier

- (1) Raise the rear of the vehicle with a hoist. Safely support the frame ahead of the rear springs.
- (2) Remove the wheels.
- (3) Disconnect the propeller shaft at the rear yoke.
- (4) Disconnect the shock absorbers at the axle mounting.
- (5) Disconnect the brake hydraulic hose at the bracket on the tubular cross member near the right frame side rail. Tape end of hose to keep out dirt. Disconnect breather hose.
- (6) Support the axle on a jack.
- (7) Remove the axle U-bolts.
- (8) Slide the axle from under the vehicle.

2-99. Cleaning, Inspection and Repair.

- a. Clean all parts with drycleaning solvent or mineral spirits base paint thinner; dry with compressed air.
- b. Inspect bumpers and seals for abrasions, corrosion, wear and deterioration.
- c. Clean and lightly oil threads of all attaching bolts and nuts.
- d. Inspect ventilation lines and hoses for cracks and punctures.
- e. Replace all parts that are unfit for further service.

2-100. Installation.

a. Springs. (Fig 2-75)

- (1) Position spring assembly on spring seat so that head of spring center bolt is properly located in the hole in spring seat.
- (2) Position U-bolts on top of spring assembly.
- (3) Position U-bolts over axle tube and up through spring plate.
- (4) Install four lock washers and nuts on U-bolts. Do not tighten.
- (5) Position spring onto front hanger pin. Install flat washer and nut. Do not tighten.
- (6) Position rear spring eye in shackle. Install spring rear eye bushing bolt and nut. Do not tighten.

NOTE

Tighten U-bolt nuts evenly so that the distance from nut to end of threads is approximately the same.

- (7) Tighten U-bolt nuts to 90-100 lbs-ft.
- (8) Tighten front and rear spring hanger pin and shackle bolt nuts to 55-75 lbs-ft.
- (9) Install spring bumper to frame and secure with bolts, nuts and lockwashers.
- (10) Remove jack stands and lower vehicle to floor.
- (11) Remove floor jack from under vehicle.

b. Shock Absorber Attaching Pins (Fig 2-75)

- (1) Position shock absorber attaching pins in axle housing brackets.
- (2) Install nut and tighten.

c. Shock Absorbers. (Fig 2-75)

- (1) Position end of shock absorber and bushings over frame bracket mounting pin.
- (2) Install flat washer and nut. Do not tighten.
- (3) Extend shock absorber as required to position over axle housing bracket mounting pin.
- (4) Install flat washer and nut.
- (5) Tighten both upper and lower mounting pin nuts.

d. Axle Shafts.

- (1) Position new gasket on axle shaft assembly.
- (2) Position axle shaft in housing and engage to drive unit. Aline hub studs to axle flange holes.
- (3) Install split lock washers, spacers and lifting bracket.
- (4) Install eight nuts and lock washers. Tighten securely.
- (5) Check lubricant level and refill as required.

e. Rear Axle and Differential Carrier.

NOTE

All service replacement axle assemblies are shipped from the factory without lubricant in the differential. Lubricant must be added to the differential before the axles are installed in vehicles. Use the grade and quantity of lubricant specified in LO 9-2320-244-12. After adding differential lubricant, suspend the axle with the axle shafts horizontal and the yoke end of the pinion housing hanging down, then twirl the pinion shaft several times to assure that the lubricant gets into the pinion shaft bearings. Procedure for installing the rear axle is as follows:

- (1) Position the axle assembly under the vehicle,
- (2) Install spring to axle pad, U-bolts, nuts, and properly torque.
- (3) Connect the shock absorbers at the axle mounting pads.
- (4) Connect the propeller shaft at the rear universal joint.
- (5) Connect rear brake hose and bleed brakes.
- (6) Install wheels and lower vehicle to floor.
- (7) Fill the axle housing with the proper lubricant. For correct lubricant refer to LO 9-2320-244-12.

Section XXIV. MAINTENANCE OF BRAKES

2-101. General.

a. Service Brakes. The service brakes (fig 2-76) are the hydraulic type with full braking action at all four wheels. They are fully energized in either forward or reverse directions. Brakeshoes are full floating and self-centering. The master cylinder is mounted on the firewall in the engine compartment. The piston within the master cylinder receives mechanical pressure from the brake pedal push rod and transmits it through the brake lines as hydraulic pressure to the

wheel cylinders. This pressure forces the pistons in the wheel cylinders outward, expanding the brakeshoes against the drums bringing the vehicle to a controlled stop. The brake mechanism is protected from dirt and mud by the channel formed at the outer edge of the backing plate into which the brakedrum recesses when assembled. The wheel cylinder ends are sealed with rubber boots to keep out dust and moisture. Brakeshoe adjustment is necessary when brake linings become worn and effective brake pedal travel is reduced. Using the proper tool, adjust actuator which turns the star wheel and lengthens the adjusting screw assembly. This action adjusts the shoes until clearance between the lining and drum is within proper limits.

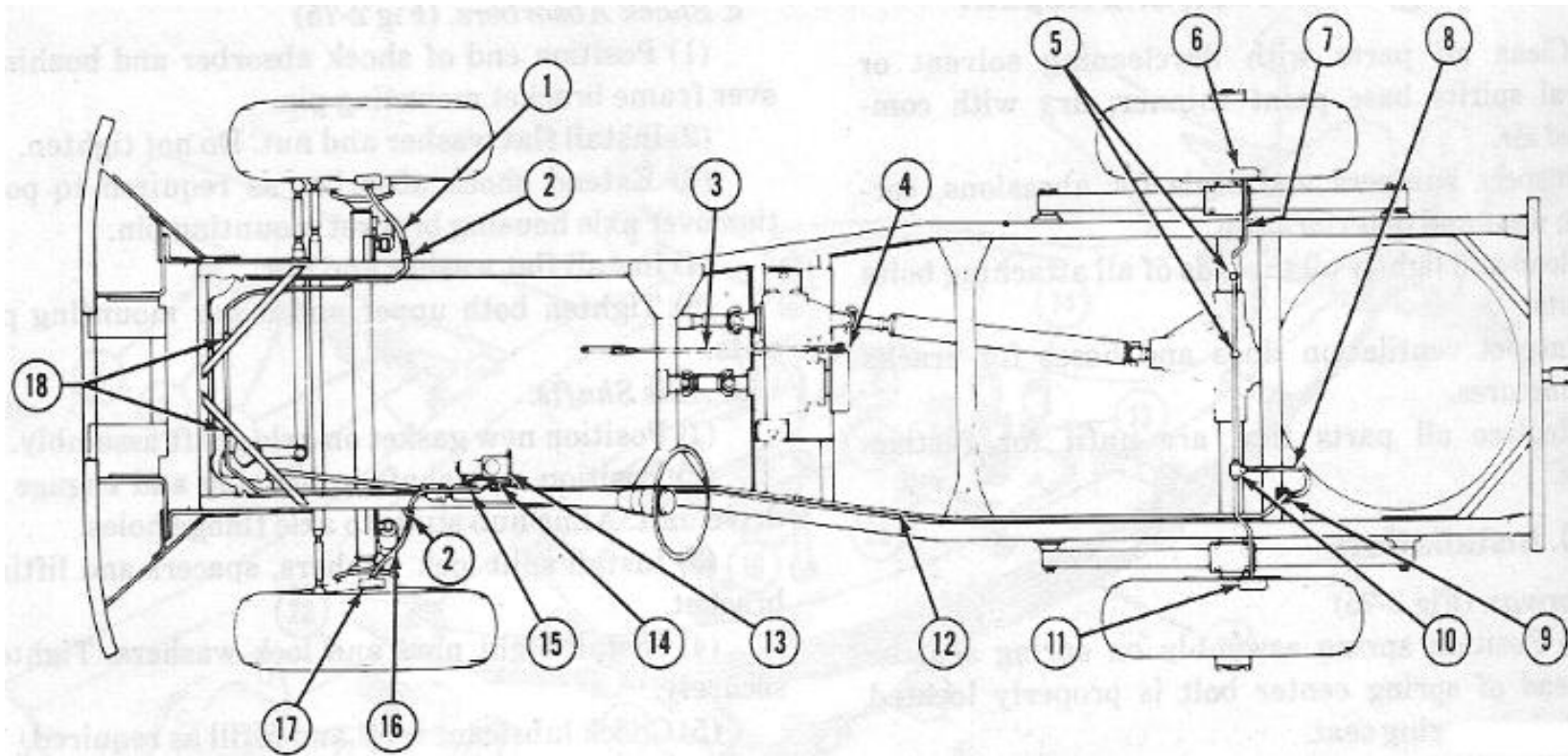

Figure 2-76. Brake system.

1 Front brake tube to right wheel cylinder flexible line	10 Rear brake tube tee
2 Clamp	11 Left rear wheel cylinder
3 Parking brake control rod	12 Rear brake tube
4 Parking brake	13 Master cylinder
5 Brake tube clips	14 Front brake tube tee
6 Right rear wheel cylinder	15 Front brake tube to clamp
7 Rear brake tube tee to right wheel cylinder tube	16 Front brake tube to left front wheel cylinder flexible line
8 Flexible line to rear brake tube tee	17 Left front wheel cylinder
9 Crossmember mount for flexible line	18 Brake tube clip

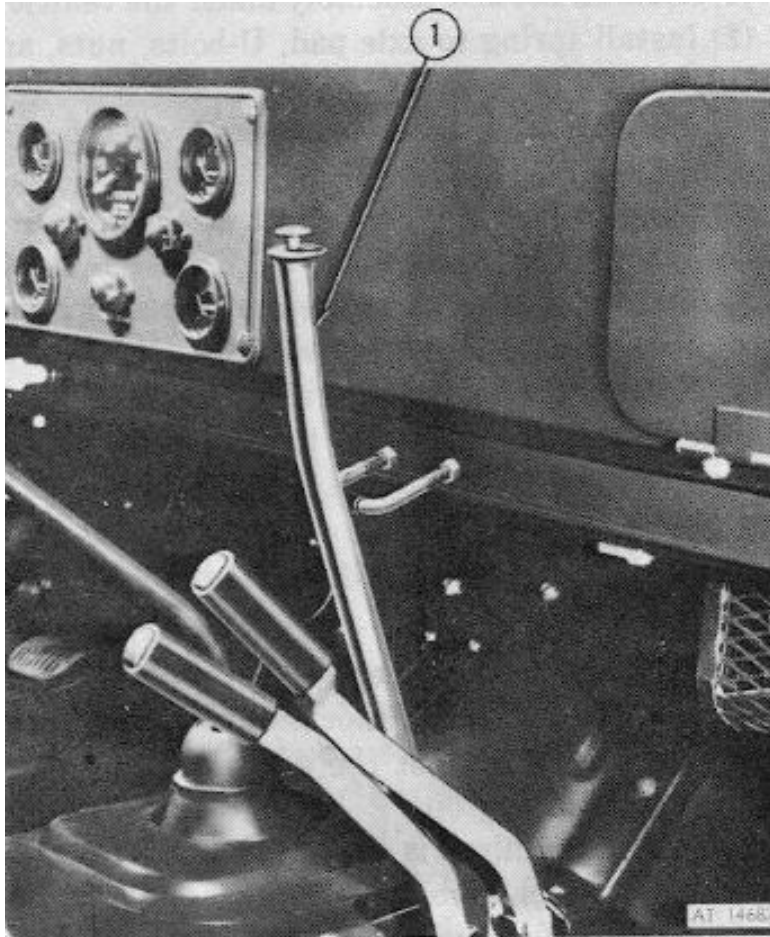

Figure 2-77. Handbrake Controls

1 Handbrake control

b. Parking Brake. The external contracting band type parking brake (fig 2-77) is mounted at the rear side of the transfer case. The brake is actuated through linkage from a lever mounted on top of the brake assembly extending into the driver's compartment.

The parking brake lever is operated by hand and has a push-button release. When the lever is pulled, tension is exerted on the parking brake rod leading to the parking brake causing the brakeshoe to press against the drum. The amount of brake grip that can be applied increases by the number of notches the brake lever is pulled. To disengage the parking brake, depress the button on top of the lever.

2-102. Maintenance and Adjustment.

a. Service Brake Adjustment. (Fig 2-78)

(1) Centralize the brakeshoes in the drums by depressing the brake pedal hard and then releasing it. Since the brakes are of the self-centering type, they require no anchor adjustments.

(2) Hoist all four wheels off the ground.

- (3) Remove the adjusting hole dust clip from the back of the brake backing plate.
- (4) Use Brake Adjusting Tool to turn the star wheel. Raise the handle of the tool to tighten the shoes against the drum.
- (5) When the brakeshoes are tight against the drum, turn the star wheel in the opposite direction until the vehicle wheel just rotates freely without brake drag.
- (6) Repeat the above procedure for all four wheels.

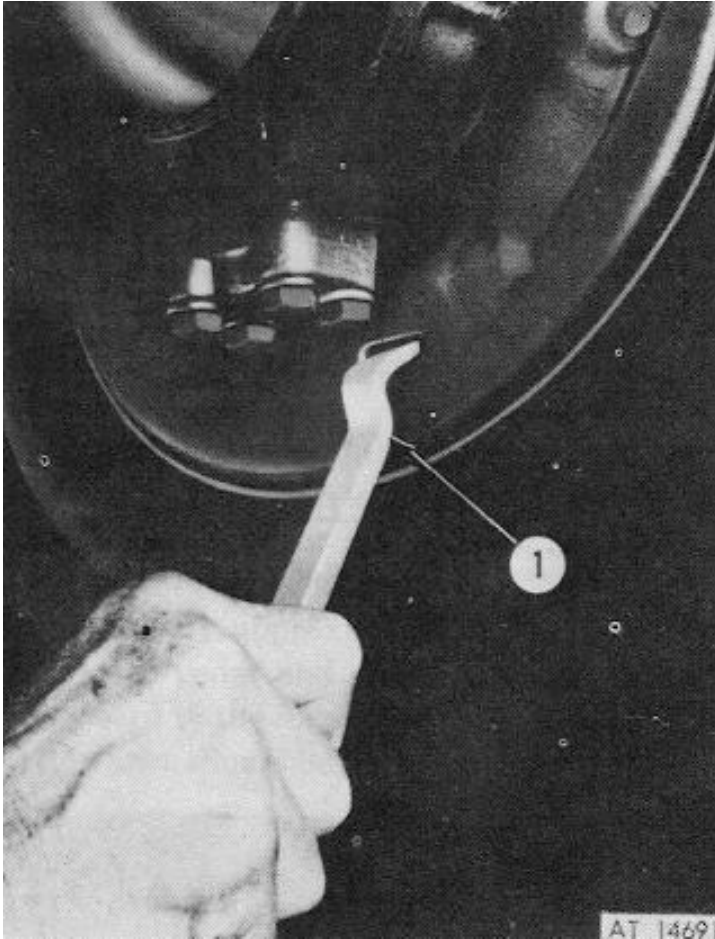

Figure 2-78. Brakeshoe adjustment

1 Adjusting tool

b. Hand Brake Adjustment (Fig 2-79)

- (1) Place the vehicle on a level floor and place the hand brake in the fully released position.
- (2) Remove the cotter pin and clevis pin that attach the control rod to the cam levers.
- (3) Remove the locking wire from the anchor Screw,
- (4) Loosen the two jamnuts on the adjusting J-bolt and the two jamnuts on the adjusting screw.
- (5) Insert a 0.015-inch thickness gage between the brake lining and the drum at the anchor clip. Turn the anchor screw as required until slight friction is felt

as the gage is withdrawn.

(6) Insert the thickness gage between brake lining and drum above J-bolt and turn the upper nut on the adjusting J-bolt as required to establish the same clearance as above.

(7) Insert the thickness gage between brake lining and drum below J-bolt, hold the adjusting screw, and turn the lower nut on the adjusting screw as required to establish the same clearance as above.

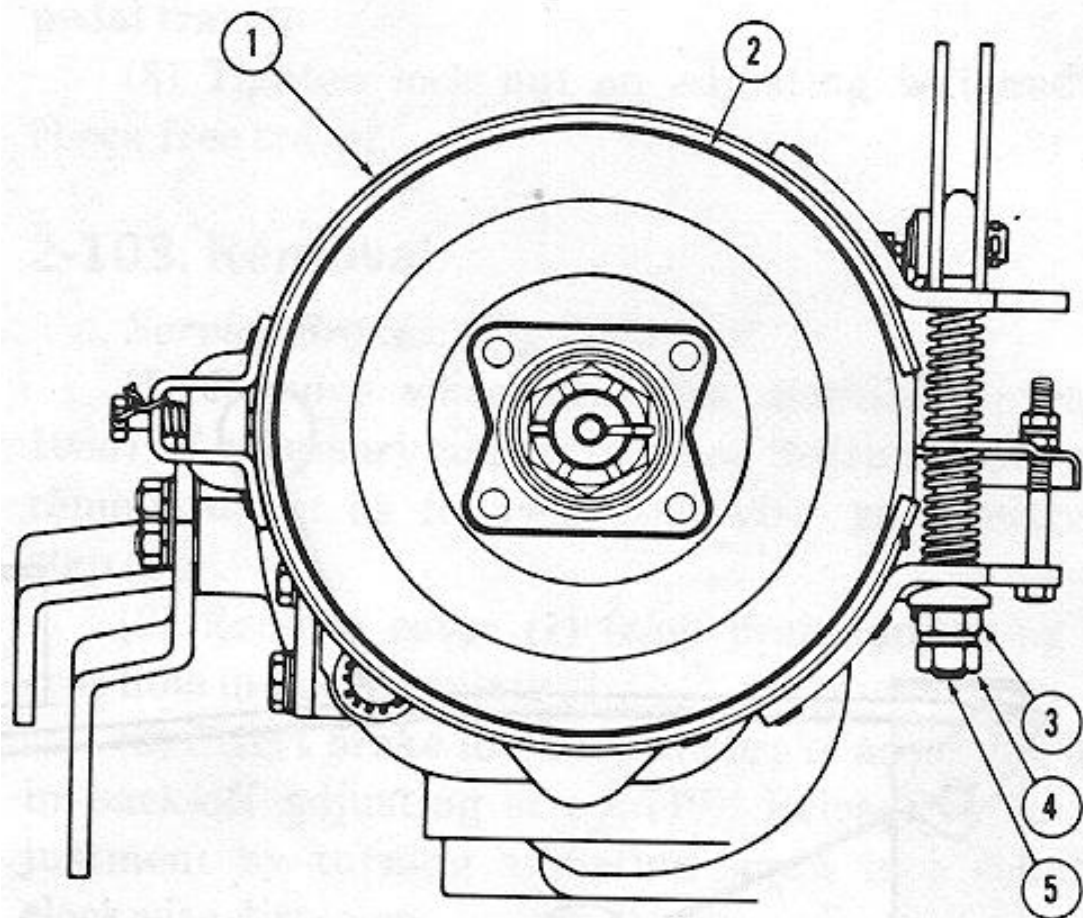

Figure 2-79. Transmission band type brake adjustment

- 1 Brake band
- 2 Brake drum
- 3 Adjustment nut
- 4 Lock nut
- 5 Bolt

(8) Check the clearance between the lining and the drum at several points, Clearance should be approximately 0.015-inch at all points.

(9) When the adjustment has been completed, tighten the jamnuts on the adjusting J-bolt and the adjusting screw. Secure the anchor screw with locking wire,

attaching the wire to the bracket in such a manner that it will not interfere with the anchor screw spring,

(10) Adjust the handbrake control rod before connecting it to the cam levers,

c. Adjust Hand brake Control Rod (Fig 2-80)

(1) With the brake control rod detached from the cam levers, loosen the nut at the yoke end of the brake control rod and turn the rod in the yoke until the eye of the rod is in alinement with the clevis pin holes in the two cam levers.

(2) Attach the control rod to the cam levers with the clevis pin and cotter pin.

(3) Tighten the nut against the yoke.

(4) With the brake band and control rod properly adjusted, the pawl should be engaged in the third to fifth notch of the sector for full application of the brake.

d. Hydraulic System Bleeding Procedure, The hydraulic brake system must be bled whenever any line has been disconnected or if air is contained in the system, A spongy pedal feel when the brakes are applied may indicate presence of air in the system. A hydraulic brake pressure filler is available for this operation; however, the system may be manually bled without the use of the pressure filler.

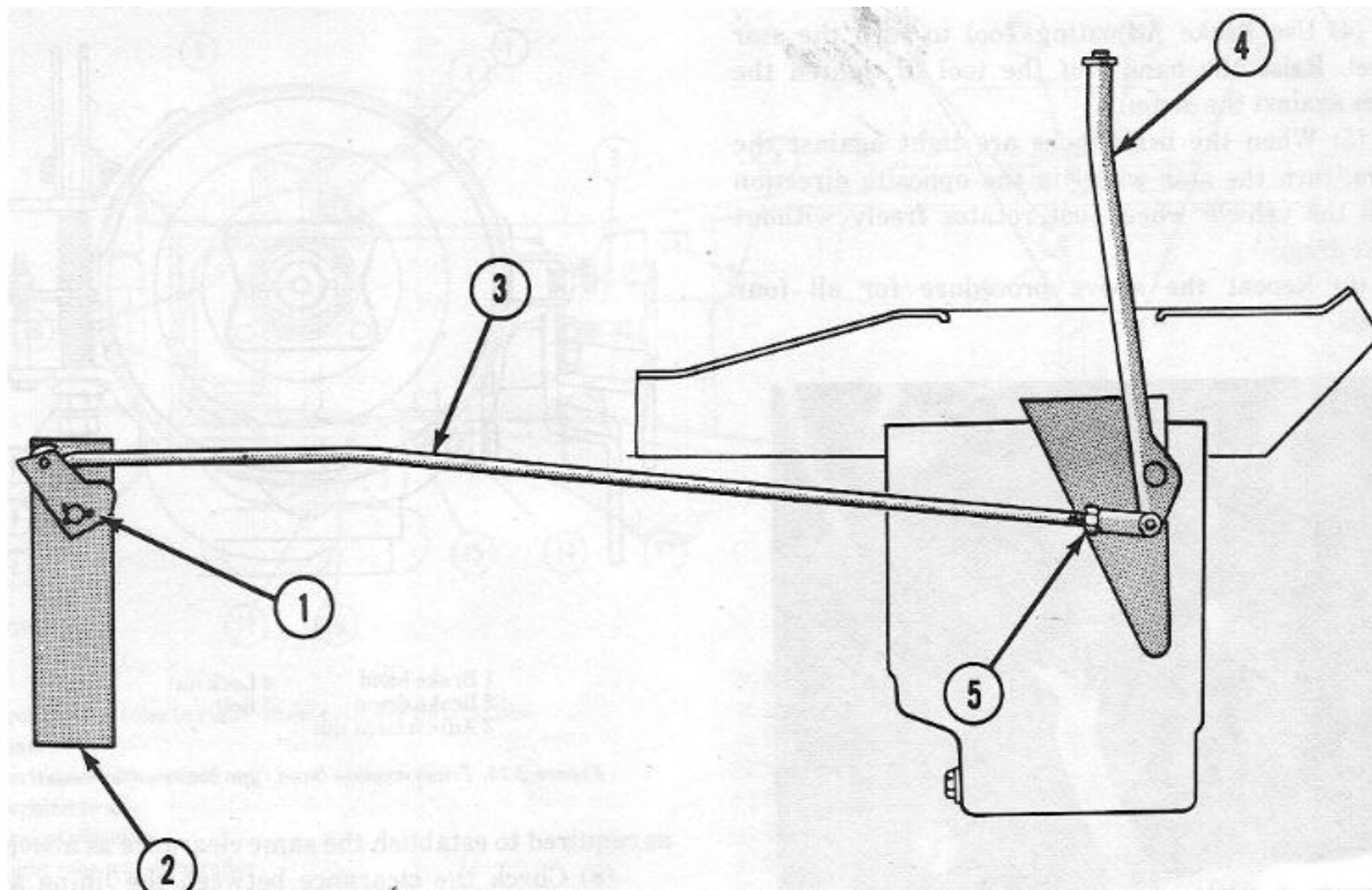

Figure 2-80. Handbrake linkage.

- 1 Operating cam
- 2 Brakeshoe and lining
- 3 Operating rod
- 4 Parking brake handle
- 5 Adjusting nut

- (1) Pressure bleeding. Insure that the pressure filler contains an adequate supply of brake fluid.
 - (a) Clean all foreign matter from reservoir and remove master cylinder reservoir cover and diaphragm.
 - (b) Fill master cylinder to top of reservoir with clean brake fluid.
 - (c) Install the proper adapter on master cylinder reservoir.
 - (d) Connect pressure hose between adapter and pressure bleeding tank. Close the filler hose shut-off cock.
 - (e) Connect a compressed air hose to the air valve in top of the pressure bleeding tank and charge the tank to a minimum of 25 psi as indicated on the pressure gage.
 - (f) Loosen the pressure hose connection at the master cylinder adapter and open the filler hose shutoff cock slightly. When the fluid flowing from the loosened connection is free from air bubbles, close the filler hose shut-off cock and tighten the hose connection at master cylinder adapter.
 - (g) Open the filler hose shut-off cock fully and observe pressure indicator. The pressure should be maintained at approximately 25 psi.
 - (h) Attach a bleeder hose to the bleeder screw of the right rear wheel cylinder (fig 2-81). Submerge the free end of bleeder hose in a glass receptacle containing a small amount of clean unused brake fluid. Open the bleeder screw and allow fluid to flow into the receptacle until the fluid is entirely free from air bubbles.
 - (i) Close the bleeder screw and remove bleeder hose.
 - (j) Bleed the left rear, right front, and left front wheel cylinders in that order, following the procedure described in (h) above.
 - (k) When the left front wheel cylinder has been bled, and while the bleeder hose is still attached to bleeder screw (screw open), close the filler hose shut-off cock and remove hose from master cylinder reservoir adapter.
 - (l) Depress brake pedal and hold it down while closing the bleeder screw at the left front wheel cylinder.
 - (m) Release brake pedal and remove bleeder hose from bleeder screw.
 - (n) Remove adapter from master cylinder reservoir. Check fluid level in reservoir and refill as required.
 - (o) Install master cylinder reservoir diaphragm and cover.
- (2) Manual bleeding.
 - (a) Clean all foreign matter from master cylinder reservoir and remove master cylinder reservoir cover and diaphragm.
 - (b) Fill master cylinder reservoir with clean brake fluid.
 - (c) Attach a bleeder hose to the bleeder screw of the right rear wheel cylinder. Submerge free end of bleeder hose in a glass receptacle containing a small amount of clean unused brake fluid.
 - (d) Open bleeder screw (fig 2-81) and depress the brake pedal a full stroke. Close the bleeder screw and release brake pedal.
 - (e) Continue operating the pedal, refilling the main cylinder reservoir when required, until no air bubbles emerge from the bleeding tube. Close the bleeder screw when the brake pedal is on the down stroke.
 - (f) Repeat steps (a) through (e) to bleed the left rear, right front and left front wheel cylinders.
 - (g) Fill reservoir and replace master cylinder reservoir diaphragm and cover.
 - (h) Apply approximately 75 pounds pressure to the brake pedal and check pedal clearance from the toe board to the forward edge of brake pedal pad. This clearance should be a minimum of 5 inches.

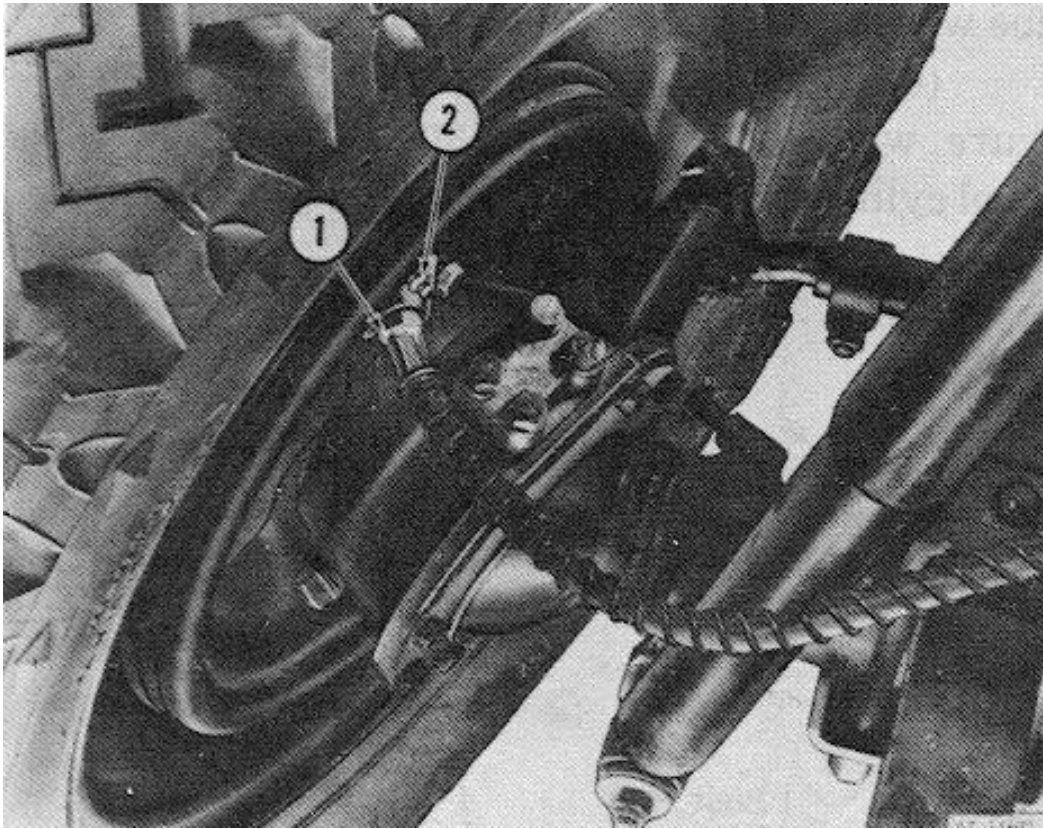

FIGURE 2-81. Bleeding Brakes

- 1 Brake hose
- 2 Bleeder screw

e. Brake Pedal Adjustment (Fig 2-86)

- (1) Loosen adjusting bolt lock nut (7 fig 2-86) installed through the brake pedal mounting bracket (20 fig 2-86).
- (2) Adjust the adjustment bolt so that free travel measured at the center of pedal pad is ½-inch. Turn adjusting bolt (6 fig 2-86) clockwise to decrease free pedal travel and counter-clockwise to increase free pedal travel.
- (3) Tighten lock nut on adjusting bolt and recheck free travel.

2-103. Removal.

a. Service Brakes. (Fig 2-82)

- (1) Remove wheel and tire assembly (para 2-108a). If necessary to provide shoe to drum clearance, remove drum as follows; otherwise, go directly to step (4).
- (2) Remove cover (1) from brake adjusting access hole in backing plate (4).
- (3) Insert brake tool into the brake adjusting hole in back-off adjusting screw (10). Release brake adjustment by turning adjusting screw in a counterclockwise direction.
- (4) Remove brakedrums.

(5) Using brake spring remover tool, remove primary and secondary brakeshoe return springs (8). Note that secondary return spring overlaps primary return spring.

(6) Remove anchor pin washer (6), holddown spring (15) and holddown pins (2).

(7) Remove primary and secondary brakeshoe assemblies (7) and adjusting screw assembly (9, 10, 11) and spring from backing plate (4).

b. Hand Brake. (Fig 2-79)

(1) Disconnect the brake rod from the brake cam lever.

(2) Remove 3-inch screw from lining assembly and cast bracket,

(3) Cut brake band anchor lock wire and remove brake band anchor clip screw, taking care not to lose brake band anchor spring located inside the bracket.

(4) Remove two brake adjusting nuts from brake adjusting bolt. At this point, loosen the two bolts holding the ends of the rear transfer case crossmember until the crossmember drops approximately ½-inch.

(5) Lift brake adjusting bolt upwards until it clears the lower ear of the brakeshoe assembly and remove the bottom spring.

(6) Continue to lift the brake adjusting bolt and pull the brakeshoe assembly rearward at the same time until the brake band bolt clears the cast retainer.

Brakeshoe assembly is now off.

(7) If the adjusting J-bolt, cam levers or spacer link requires replacement, remove the cotter pin and clevis pin that attach the two levers and the spacer link to the J-bolt. If the spacer link stud in the brake support requires replacement, remove the nut, lock washer and stud.

(8) Remove cotter pin, nut and flat washer securing companion yoke to transfer case output shaft.

(9) Remove four nuts, lock washers and bolts securing brake drum to companion yoke.

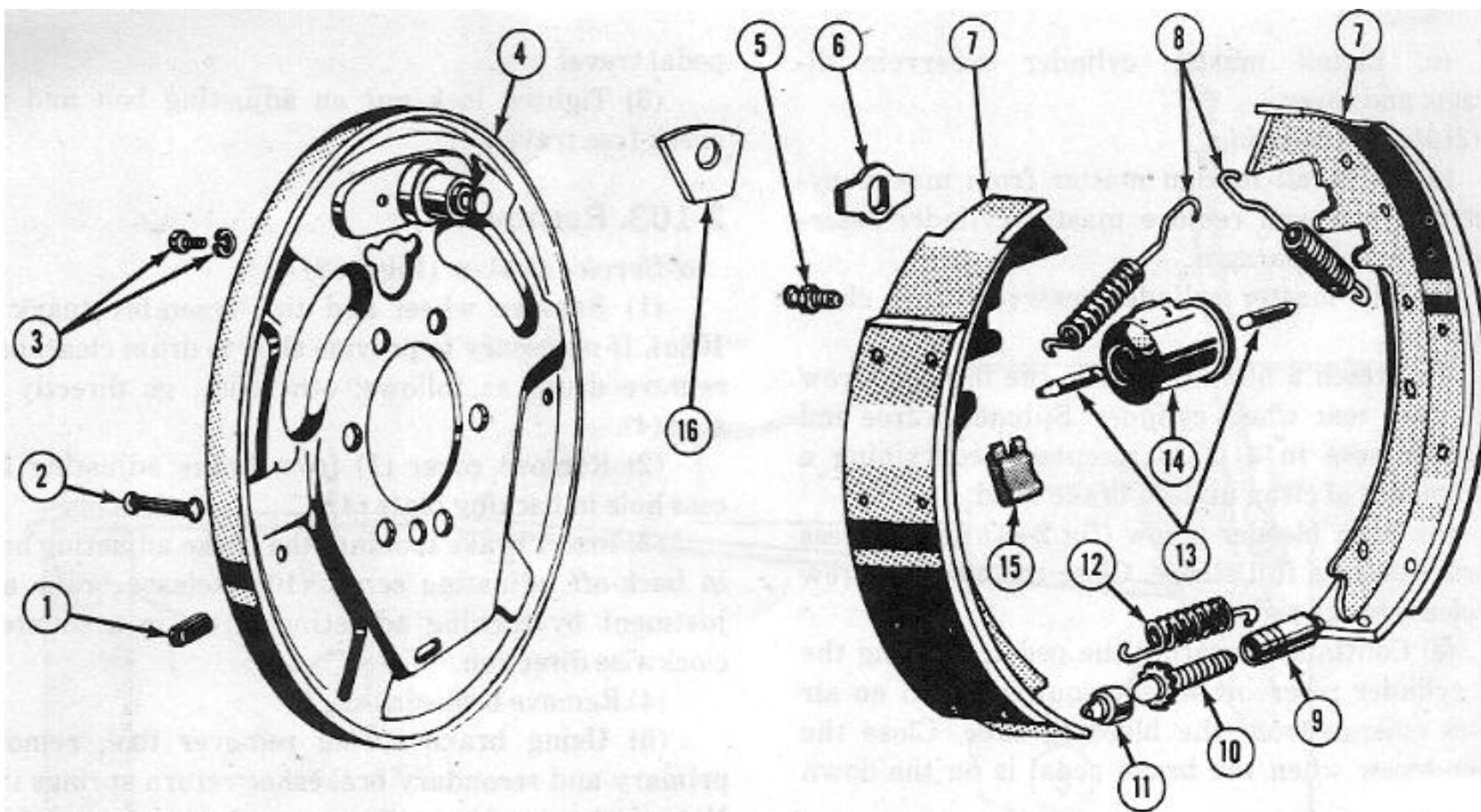

Figure 2-82. Brake assembly

1 Adjusting hole cover	5 Bleeder screw	9 Pivot nut	13 Push rod
2 Holddown pin	6 Anchor pin washer	10 Adjusting screw	14 Wheel cylinder
3 Lock washer and cap screw	7 Brakeshoe	11 Socket	15 Holddown spring
4 Backing plate	8 Return spring	12 Return spring	16 Self-centering anchor block

(10) Remove companion yoke and brakedrum from transfer case.

c. Hydraulic Brake Hoses and Cylinders.

(1) Front brake hoses.

(a) Remove U-clip which secures hose to frame side rail bracket.

(b) Loosen male fitting which secures brake pipe to hose.

(c) Loosen and disconnect flexible hose fitting from wheel cylinder.

(d) Remove hose from wheel cylinder connector.

(2) Rear hose.

(a) Remove U-shaped clip which secures pipe to frame crossmember. Disconnect fitting to hose.

- (b) Disconnect fitting and remove flexible hose from rear axle housing tee.
- (3) Wheel cylinders. (Fig 2-83)
- (a) Remove tire and wheel, hub and drum assembly (para 2-108c).
- (b) Remove hose or pipe connecting brake line to wheel cylinder.
- (c) Disconnect brakeshoe primary and secondary return springs.
- (d) Spread brakeshoes apart and disconnect shoe webs from wheel cylinder piston pins.
- (e) Remove two bolts and lock washers which secure wheel cylinder to flange plate and remove wheel cylinder. (Fig 2-84)

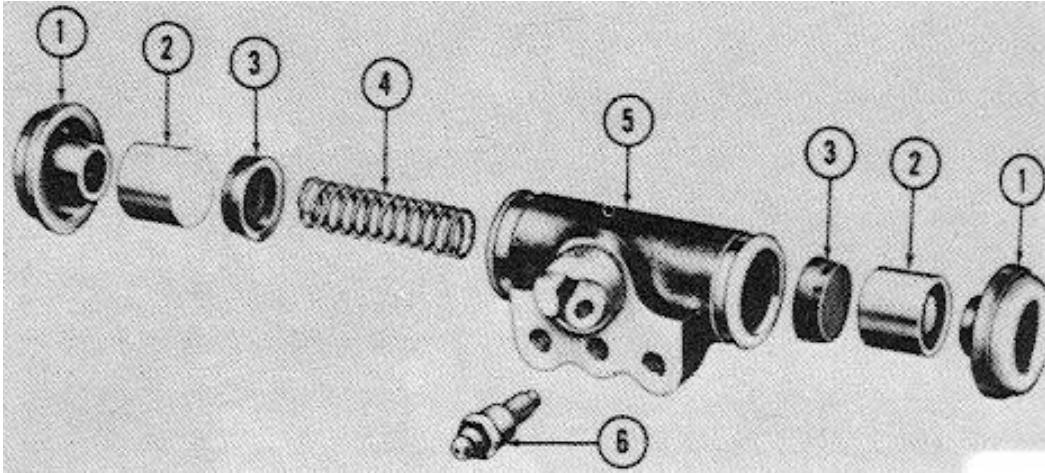

Figure 2-83. Wheel brake cylinder

- 1 Boot
- 2 Piston
- 3 Cylinder cup
- 4 Cup spring
- 5 Cylinder
- 6 Bleeder screw

- (4) Master cylinder. (Fig 2-85)
- (a) Loosen pipe fittings and disconnect pipes from master cylinder vent and rear reservoir outlet.
- (b) Remove two nuts and lock washers which secure master cylinder to firewall. Disconnect master cylinder from firewall attaching studs.

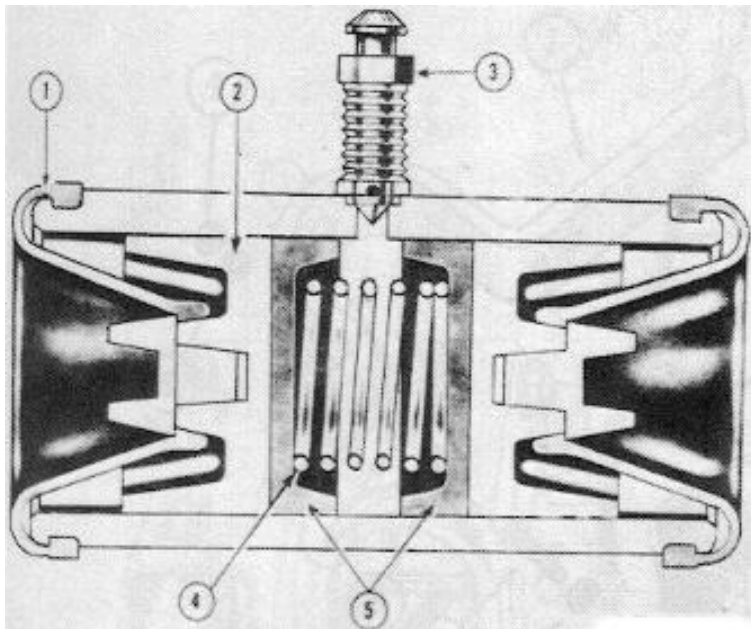

Figure 2-84. Brake wheel cylinder.

- 1 Cylinder boot
- 2 Piston
- 3 Bleeder screw
- 4 Cup spring
- 5 Cylinder cup

(5) Distribution block.

(a) Disconnect stoplight cable connector from switch terminal.

(b) Loosen fittings and disconnect pipes from master cylinder reservoir outlet.

(c) Loosen fittings and disconnect pipes from distribution block to front and rear brakes.

(d) Remove bolt and washer which secure distribution block to frame and remove distribution block assembly.

d. Hydraulic Brake Warning Switch..

(1) Disconnect warning switch cable connector from switch terminal.

(2) Remove contact switch from distribution block assembly.

e. Brake Pedal. (Fig 2-86)

(1) Disconnect brake pedal return spring from pedal.

(2) Remove nut and bolt which secure brake pedal to brake pedal mounting bracket.

(3) Lower and remove brake pedal from brake pedal bracket.

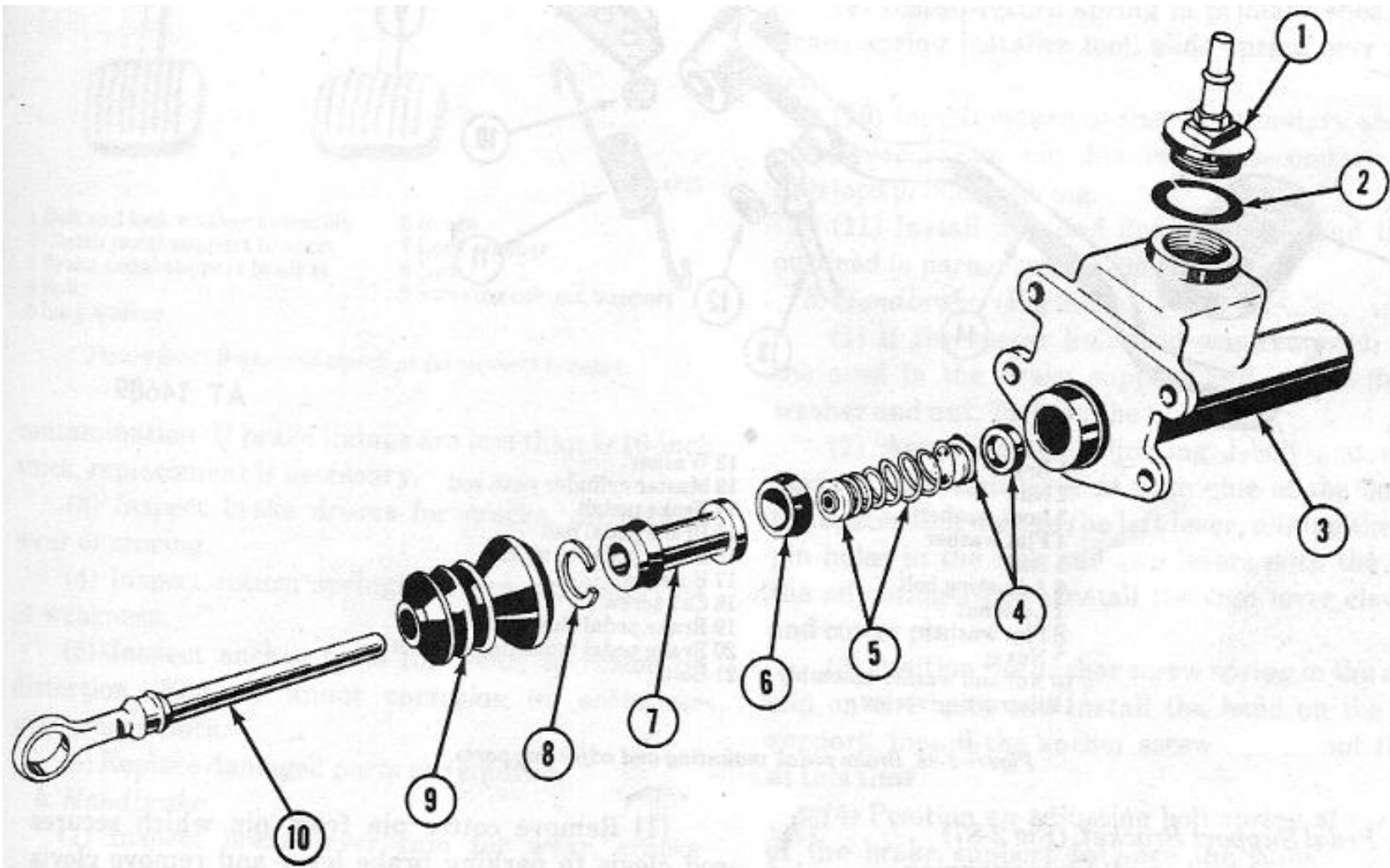

Figure 2-85. Brake master cylinder.

- 1 Vented filler cap
- 2 Filler cap gasket
- 3 Supply tank
- 4 Valve and seat
- 5 Valve return spring
- 6 Primary cup
- 7 Piston
- 8 Piston stop ring
- 9 Boot
- 10 Push rod

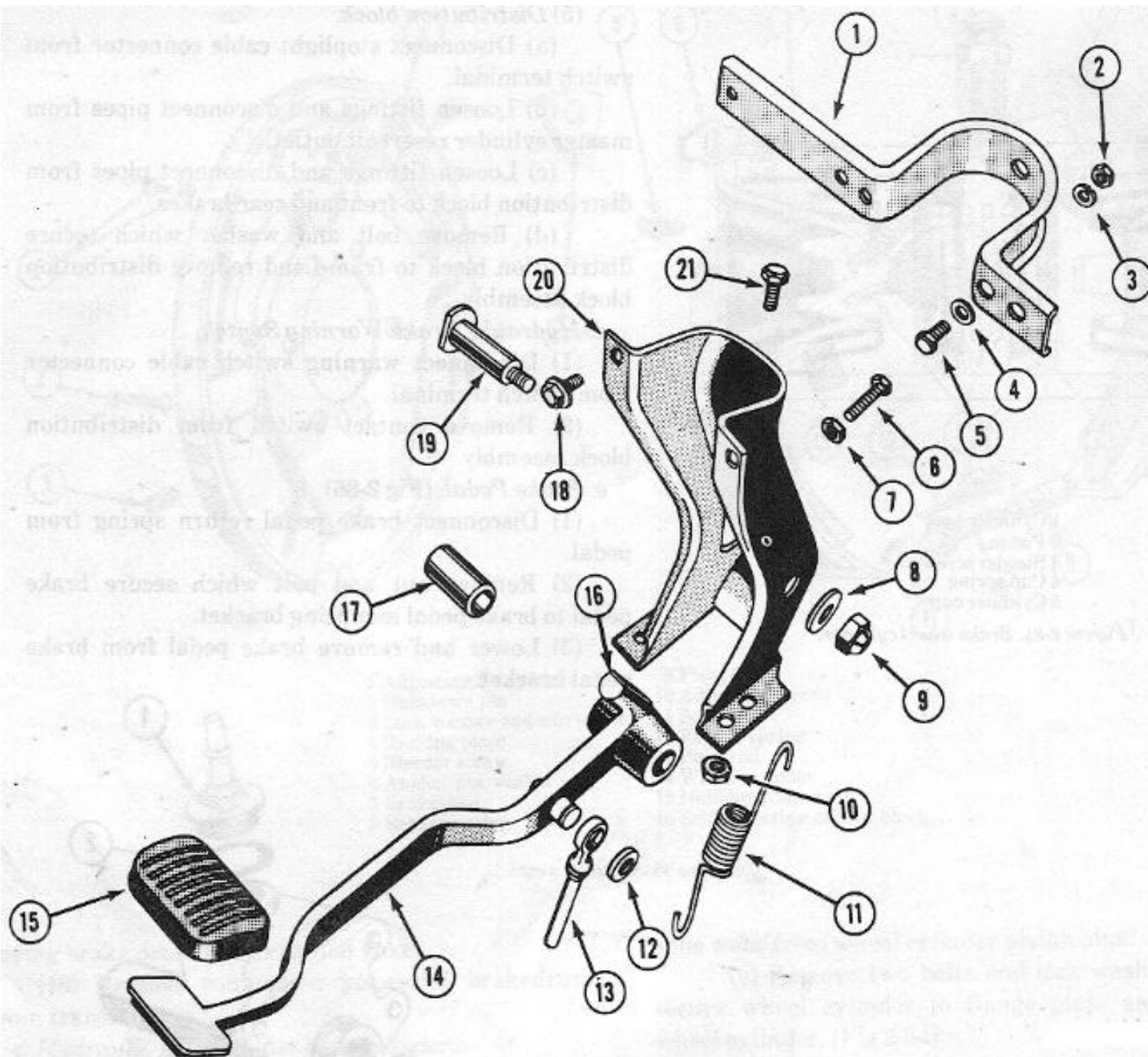

Figure 2-86. Brake pedal, mounting and adjusting parts.

1 Brace	12 Washer
---------	-----------

2 Nut	13 Master cylinder push rod
3 Lock washer	14 Brake pedal
4 Flat washer	15 Brake pedal pad
5 Bolt	16 Brake pedal bumper
6 Adjusting bolt	17 Bushing
7 Lock nut	18 Cap screw
8 Flat washer	19 Brake pedal shaft
9 Nut	20 Brake pedal mounting bracket
10 Nut and washer assembly	21 Bolt
11 Retracting spring	

f Brake Pedal Support Bracket. (Fig 2-87)

- (1) Disconnect brake pedal return spring.
- (2) Remove bolts and nuts securing support bracket to firewall.
- (3) Remove bolts securing support bracket to instrument panel.
- (4) Remove nut and lock washer securing brace rod to support bracket.
- (5) Remove brake pedal and support bracket as an assembly.
 - (1) Remove cotted pin from pin which secures rod clevis to parking brake lever and remove clevis pin.
 - (2) Remove three bolts and lock washers which secure parking brake lever to transmission bracket.
 - (3) Remove parking brake lever.

2-104. Cleaning and Inspection.

a. Service Brakes.

- (1) Clean all dust and foreign material from brake flange plates.
- (2) Inspect brake linings for grease or lubricant contamination. If brake linings are less than 1/16-inch thick, replacement is necessary.
- (3) Inspect brake drums for cracks, distortion, wear or scoring.
- (4) Inspect return springs for cracks, distortion or weakness.
- (5) Inspect anchor bolts for wear, corrosion or distortion. Remove minor corrosion or abrasions with crocus cloth.
- (6) Replace damaged parts as required.

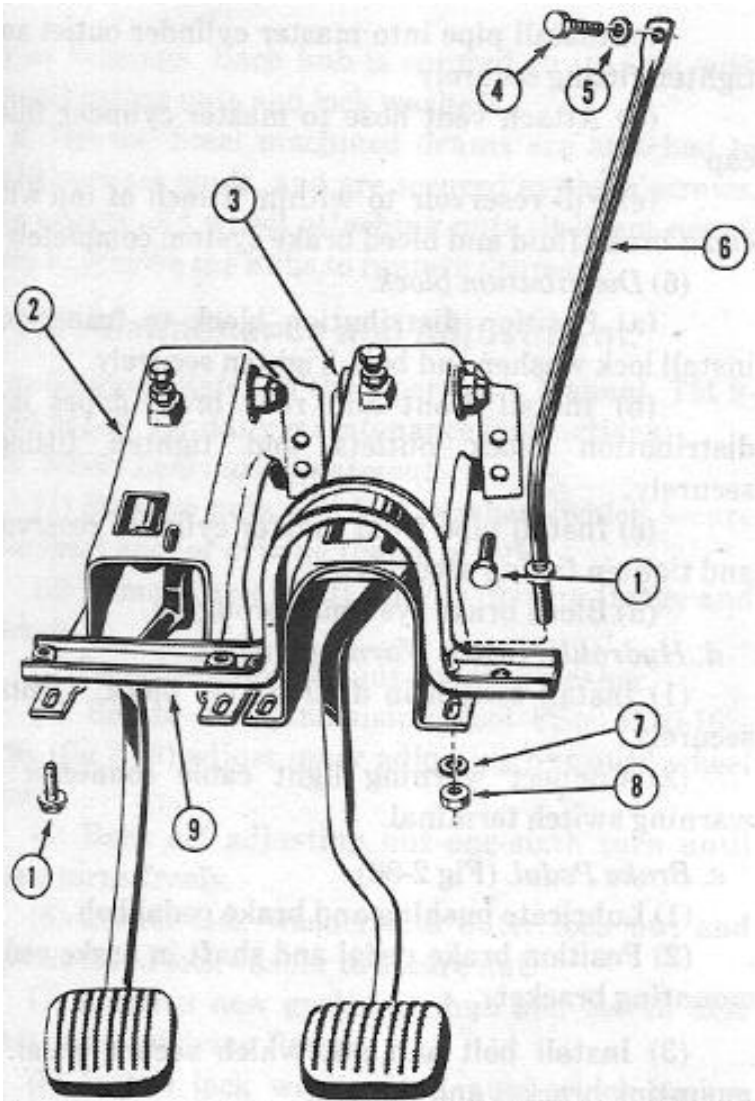

Figure 2-87. Brake and clutch pedal support bracket

- 1 Bolt and lock washer assembly
- 2 Clutch pedal support bracket
- 3 Brake pedal support bracket
- 4 Bolt
- 5 Lock washer
- 6 Brace
- 7 Lock washer
- 8 Nut
- 9 Steering column Support

b. Handbrake

- (1) Inspect brake lever cam for wear, cracks and distortion.
- (2) Inspect parking brake lever pawl for wear and chipped teeth. Check action of release button, rod and pawl for ease of operation and correct spring action.

c. Wheel Cylinders and Brake Hoses.

- (1) Inspect wheel cylinder cups and seals for leakage.
- (2) Inspect mounting bolts for corrosion, stripped and/or cross-threading.
- (3) Inspect bleeder valves for corrosion and proper seal.

2-105. Installation.

a. Service Brakes. (Fig 2-82)

- (1) Match a primary with a secondary brakeshoe and place in their relative position on a work bench.
- (2) Lubricate threads of adjusting screw and install between primary and secondary shoes with star wheel next to secondary shoe.
- (3) Lubricate shoe tab contact area on flange plate.
- (4) Overlap anchor ends of primary and secondary brakeshoes and install adjusting spring.
- (5) Spread anchor ends of brakeshoes to maintain adjusting lever and spring in position.
- (6) Holding brakeshoes in their relative position, place brakeshoe assemblies on support and over anchor pin.
- (7) Install retainer pins and retainer springs.
- (8) Install anchor pin plate.
- (9) Install return spring in primary shoe. Using brake spring installer tool, slide spring over anchor pin.
- (10) Install return spring in secondary shoe and slide, over anchor pin. Insure that secondary spring overlaps primary spring.
- (11) Install hub and drum, wheels and tires as outlined in paragraph 2-110b and d.

b. Hand brake. (Fig 2-79)

- (1) If the spacer link stud was removed, install the stud in the brake support and install the lock washer and nut. Tighten the nut.
- (2) Assemble the adjusting J-bolt and related parts with a cam lever at each side of the bolt and the spacer link next to the left lever, alining the clevis pin holes in the link and two levers with the eye in the adjusting J-bolt. Install the cam lever clevis pin and cotter pin.
- (3) Position the anchor screw spring in the anchor clip on the band and install the band on the brake support. Install the anchor screw but do not tighten at this time.
- (4) Position an adjusting bolt spring at each side of the brake support between the support and the band ends, and install the adjusting J-bolt and attached cam levers and spacer link, inserting the bolt through the band ends, two springs and brake support. Install the plain washer and two jamnuts on the lower end of the bolt, but do not tighten at this time.
- (5) Attach the front end of the spacer link to the spacer link stud and install the cotter pin.
- (6) Install the adjusting screw up through the band lower end and the brake support and install the lock washer and two jamnuts. Do not tighten the nuts at this time.
- (7) Raise transfer case crossmember and tighten attaching bolts.
- (8) Adjust the band and control rod as outlined in paragraph 2-102b.

c. Hydraulic Brake Hoses and Cylinders.

(1) Front brake hoses.

- (a) Position flexible hose and install fitting in wheel cylinder connector. Tighten securely.
- (b) Position hose fitting through hole in frame side rail bracket and tighten male fitting which secures brake pipe to hose.
- (c) Install U-clip which secures hose to frame side rail bracket.
- (d) Bleed front brake system thoroughly.

(2) Rear hose.

- (a) Connect flexible hose to rear axle housing tee and tighten.
 - (b) Connect flexible hose fitting to distribution block pipe and tighten securely.
 - (c) Install U-shaped clip which secures pipe to frame cross-member bracket.
- (3) Master cylinder to distribution block.
- (a) Connect pipe between master cylinder reservoir outlet and distribution block.
 - (b) Tighten fittings as master cylinder and distribution block securely.
 - (c) Bleed brake system thoroughly.
- (4) Wheel cylinders.
- (a) Position wheel cylinder on flange plate and install two bolts and lock washers. Tighten bolts securely.
 - (b) Install brake hose and/or pipe in wheel cylinder and tighten fitting securely.
 - (c) Spread brakeshoes apart and connect shoe web to wheel cylinder piston pins.
 - (d) Install brakeshoe return springs.
 - (e) Install hub and drum (para 2-110b).
 - (f) Install wheel and tire (para 2-110d).
 - (g) Bleed brake system thoroughly.
- (5) Master cylinder. (Fig 2-85)
- (a) Aline push rod in master cylinder housing and position master cylinder on firewall attaching studs.
 - (b) Install two lock washers and nuts and tighten to 20-30 lbs-ft.
 - (c) Install pipe into master cylinder outlet and tighten fitting securely.
 - (d) Attach vent hose to master cylinder filler cap.
 - (e) Fill reservoir to within 1/4-inch of top with clean brake fluid and bleed brake system completely.
 - (6) Distribution block.
 - (a) Position distribution block to frame and install lock washer and bolt. Tighten securely.
 - (b) Install front and rear brake pipes into distribution block outlets and tighten fittings securely.
 - (c) Install pipe from master cylinder reservoir and tighten fitting securely.
 - (d) Bleed brake system thoroughly.
- d. Hydraulic Brake Warning Switch.
- (1) Install switch in distribution block. Tighten securely.
 - (2) Connect warning light cable connector to warning switch terminal.
- e. Brake Pedal. (Fig 2-86)
- (1) Lubricate bushing and brake pedal bolt.
 - (2) Position brake pedal and shaft in brake pedal mounting bracket.
 - (3) Install bolt and nut which secure pedal to mounting bracket and tighten.
 - (4) Connect push rod to brake pedal and install flat washer on pin.
 - (5) Connect brake pedal return spring.
- f. Brake Pedal Support Bracket. (Fig 2-87)
- (1) Position brake pedal support bracket to firewall and install bolts and nuts. Tighten securely.
 - (2) Install support bracket-to-instrument panel bolts and tighten.
 - (3) Install brace rod into support bracket hole and secure with nut and lock washer.
 - (4) Connect brake pedal return spring.
- g. Hand brake Lever. (Fig 2-80)
- (1) Position parking brake lever on transmission bracket.

- (2) Install three bolts and lock washers which secure lever to transmission bracket and tighten.
- (3) Position parking brake rod clevis on lever and install pin through clevis and lever.
- (4) Install cotter pin through clevis pin.

Section XXV. MAINTENANCE OF WHEELS, HUBS, DRUMS AND TIRES

2-106. General.

- a. Wheels. The steel disc type semi-drop center wheels have a removable side ring properly sized to accept tube type tires only. Wheels are completely interchangeable as to location. Each wheel is secured to hubs by six right hand thread nuts.
- b. Tires. Tires are low pressure type, cross country nondirectional tread design, size 9.00-16 with eight ply rating. These low pressure type tires used on this vehicle are not to be interchanged with similar 9.00-16 type, six or ten ply tires used on other vehicles.
- c. Hubs. All hubs are mounted on opposed tapered roller bearings. Each hub is secured on its axle with two adjusting nuts and lock washers.
- d. Drums. Steel machined drums are attached to hubs over six studs, and are secured by three screws, the wheels and wheel attaching nuts. It is not necessary to remove the hubs to remove drums.

2-107. Maintenance and Adjustment.

- a. General. Refer to the Operator s Manual, TM 9-2320-244-10, for daily maintenance instructions.
- b. Wheel Bearing Adjustment,
 - (1) Remove nuts and lock washers which secure axle shaft and/or driving flange to hubs,
 - (2) Remove axle shaft and/or driving flange and gaskets.
 - (3) Remove outer lock nut and lock washer.
 - (4) Rotate hub, and using Tool FSN 5120-168-2286, (fig 2-88) adjust inner adjusting nut until wheel binds.
 - (5) Back off adjusting nut one-sixth turn until wheel turns freely.
 - (6) Install lock washer and outer lock nut and tighten. Bend lockwasher to secure nut.
 - (7) Position new gasket on hub and install axle shaft and/or driving flange.
 - (8) Install lock washer and nuts which secure axle shaft and/or driving flange to hub and tighten to 32-50 lbs-ft.

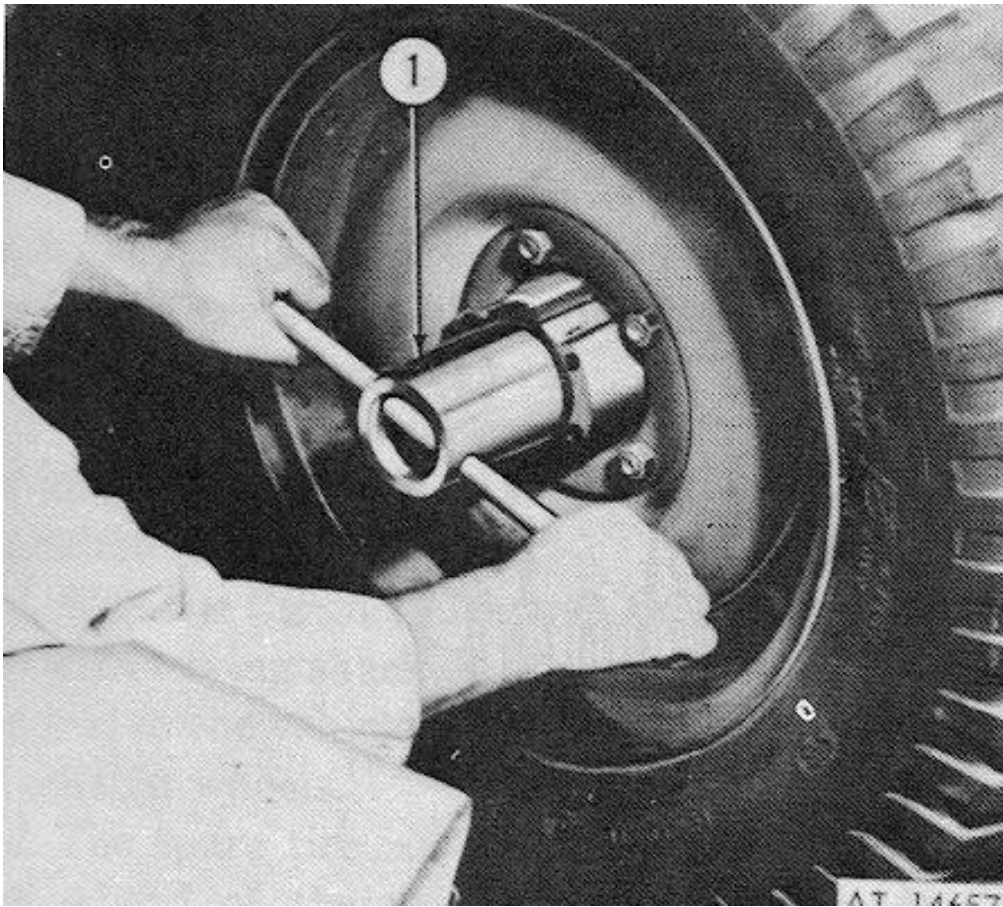

Figure 2-88. Wheel bearing nut adjusting tool.

1 Tool FSN 5120-168-2286

2-108. Removal.

a. Wheels and Tires,

- (1) Apply parking brake and block wheels.
- (2) Jack up axle of wheel to be removed.
- (3) Remove six wheel stud nuts which secure wheel to hub.
- (4) Remove wheel and tire assembly.

b. Tire and Tube.

- (1) Deflate tire completely.
- (2) Break both inner and outer tire beads free from wheel.
- (3) The lock ring is ready to demount if it is loose and turns in the rim gutter.
- (4) Locate tool notch in side ring and insert rim tool and pry up, the ring will usually spring off. If necessary, a light tap with a mallet will free last half of ring after it has been pried up.

(5) Remove tire from rim and remove inner tube.

c. Hub and Drum. (Fig 2-89 and 2-90)

(1) Remove tire and wheel (a) above.

(2) Remove three countersink screws attaching drum to hub.

(3) Strike edge of drum with a mallet and pull straight off of hub.

(4) Remove nuts and lock washers which secure axle shaft and/or driving flange to hub.

(5) Remove axle shaft and/or driving flange and gasket; discard gasket.

(6) Using Tool FSN 5120-168-2286, remove lock nut and lock washer.

(7) Remove adjusting nut, inner lock washer and pull hub off of axle housing.

d. Bearings.

(1) Pick outer bearing out of hub bearing race.

(2) Pry inner bearing oil seal out of hub.

(3) Remove inner bearing.

2-109. Cleaning, Inspection and Repair.

a. Clean bearings in drycleaning solvent or mineral spirits base paint thinner to completely remove lubricant. Air dry and repack with proper lubricant.

b. Thoroughly wash hubs with drycleaning solvent or mineral spirits base paint thinner to remove all lubricant.

c. Inspect bearing races for cracks or scoring and looseness in hubs.

e. Inspect brake drums for out-of-round or scored condition.

2-110. Installation.

a. Bearings. (Fig 2-89 and 2-90)

(1) Position inner bearing in hub race.

(2) Position new oil seal on hub. Use driver tool and hammer, seat oil seal on hub.

(3) Refer to (b) below for installation of outer bearing.

b. Hub and Drum. (Fig 2-89 and 2-90)

(1) Apply a thin film of grease to each face of wheel hub seal.

(2) Position hub assembly on axle housing.

(3) Position outer bearing and lock washer over axle housing and in hub race.

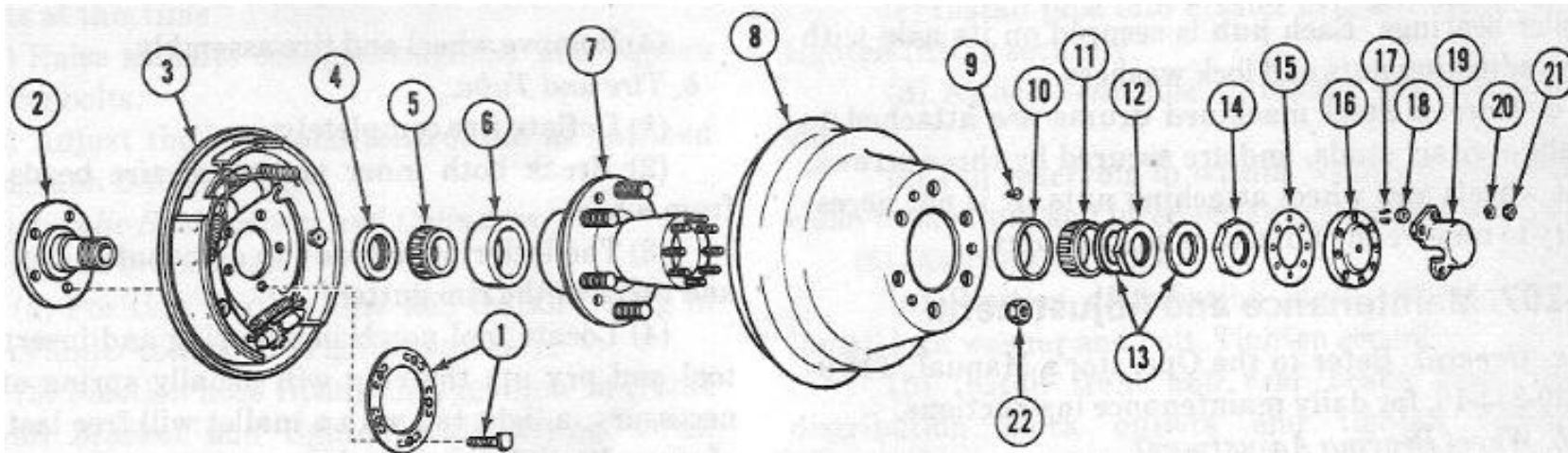

Figure 2-89. Front wheel attaching parts.

1 Lock plate and bolt	12 Inner adjusting nut
2 Front wheel spindle	13 Lock washer
3 Brake backing plate	14 Outer lock nut
4 Hub oil seal	15 Gasket
5 Inner cone and rollers	16 Driving flange
6 Inner cup	17 Split lock washer
7 Front hub	18 Nut
8 Brake drum	19 Lifting bracket
9 Screw	20 Lock washer
10 Outer cup	21 Nut
11 Outer cone and rollers	22 Wheel hub nut

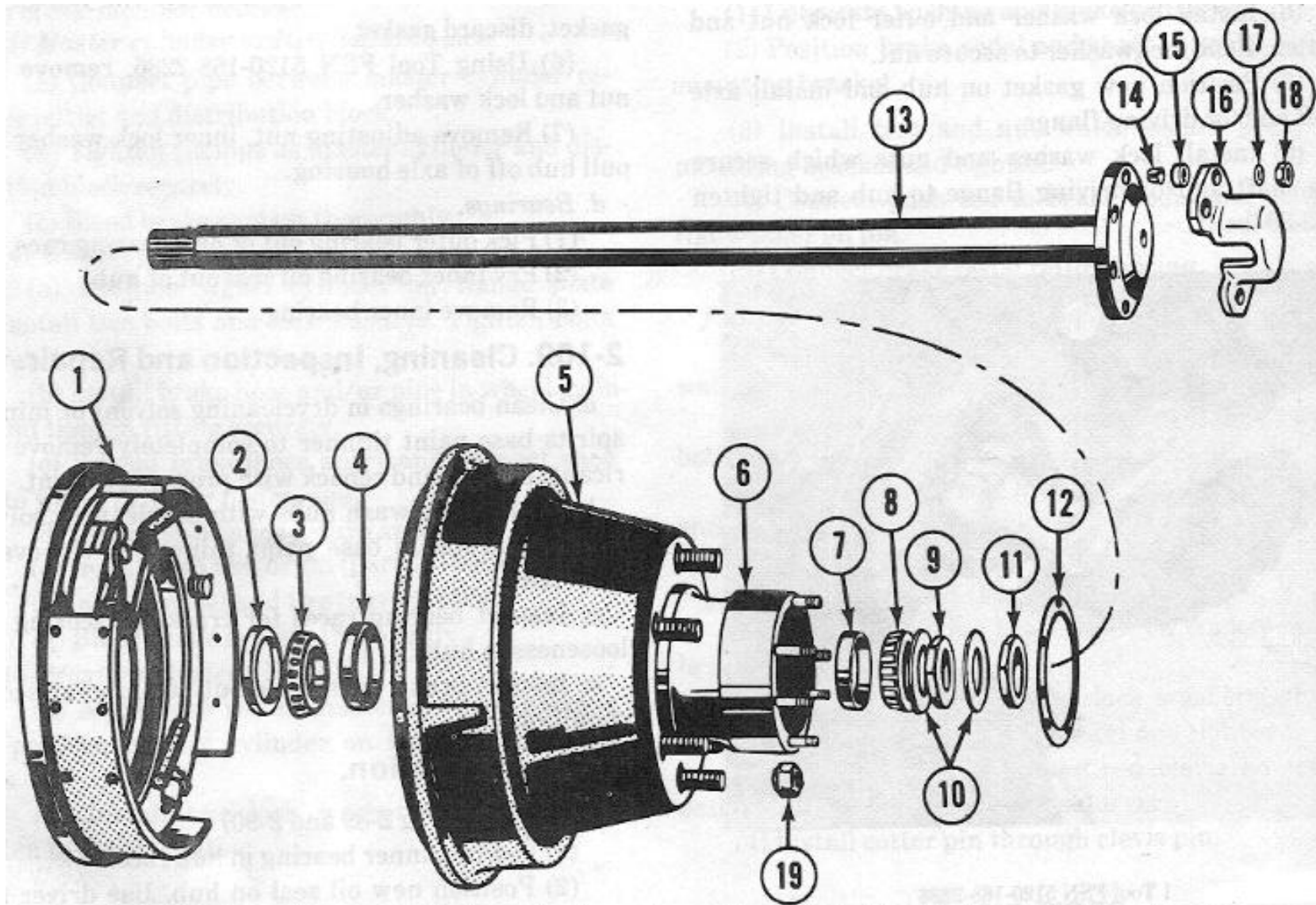

Figure 2-90. Rear wheel attaching parts.

1 Brake assembly	11 Outer lock nut
2 Oil seal	12 Gasket
3 Inner cone and rollers	13 Axle shaft
4 Inner cup	14 Split lock washer
5 Brake drum	15 Spacer
6 Hub	16 Lifting bracket
7 Outer cup	17 Lock washer
	19

8 Outer cone and rollers	18 Nut
9 Inner adjusting nut	19 Wheel lug nut
10 Lock washer	

- (4) Install bearing adjusting nut.
- (5) Adjust wheel bearing and install lock washer and lock nut in accordance with procedure in paragraph 2-107.
- (6) Install new gasket on axle shaft and/or driving flange.
- (7) Install axle shaft and/or driving flange in axle housing.
- (8) Install lock washers and attaching nuts. Tighten to 32-50 lbs-ft.
- (9) Position drum over hub and on wheel attaching studs.
- (10) Install drum to hub attaching screws.

c. Tire and Tube.

- (1) Insure that rim flanges and bead ledge areas are smooth.
- (2) Lubricate tire beads, rim flanges and bead ledge areas with a liberal amount of thin vegetable oil soap solution, or approved rubber lubricant.
- (3) Install inner tube in tire.
- (4) Place tire on rim and force first bead down into well of rim just to side of valve with foot.
- (5) To apply second bead, start at point opposite valve and press bead over rim gutter and into rim well with foot pressure.
- (6) Mount remainder of bead over rim gutter using a thin tire tool.
- (7) Install and spring the lock ring over the wheel rim.

NOTE

For a safety precaution, test the seating of the lock ring. Do this by first partially inflating the tire, then completely deflating the tire and checking the lock ring for proper seating.

- (8) Inflate the tire to proper pressure.

d. Wheels and Tires.

- (1) Position wheel over hub and on wheel studs.
- (2) Install six wheel stud nuts and tighten to a firm fit.
- (3) Insure that wheel is properly centered and tighten six stud nuts to 240-300 lbs-ft. torque.
- (4) Lower jack and store in tool compartment.

Section XXVII. MAINTENANCE OF FRAME, PINTLE, TOWING SHACKLES, LIFTING BRACKETS AND SPARE TIRE WHEEL CARRIER

2-111. General.

- a. The frame is of ladder type construction. It consists of channel type side rails, front and rear cross-members and intermediate crossmembers riveted to the side rails. The removable engine rear support crossmember is bolted to the frame side rails to facilitate power pack removal.
- b. A towing pintle capable of towing another vehicle, or loaded trailer, is centrally mounted on the frame rear crossmember.
- c. Both the Cargo Truck and Ambulance are equipped with towing shackles, two at the front and two at the rear of the vehicles. Lifting brackets are mounted on the four wheels.
- d. The spare tire is stowed against the body floor pan, ahead of the rear frame crossmember. It is secured in place by a longitudinal channel type strap pivoted from the number four crossmember and bolted to the number five crossmember (rear crossmember).

2-112. Maintenance and Adjustment.

Refer to the lubrication order, LO 9-2320-244-12, for lubrication services and prescribed lubricant for all temperature ranges. Refer to the Operator's Manual, TM 9-2320-244-10, for daily maintenance instructions.

2-113. Removal.

a. Pintle. (Fig 2-91)

- (1) Remove cotter pin, slotted nut and plain washer from the front end of pintle; remove pintle hook.
- (2) Inspect the lubrication fitting in pintle hook. If the fitting is damaged, it must be replaced.

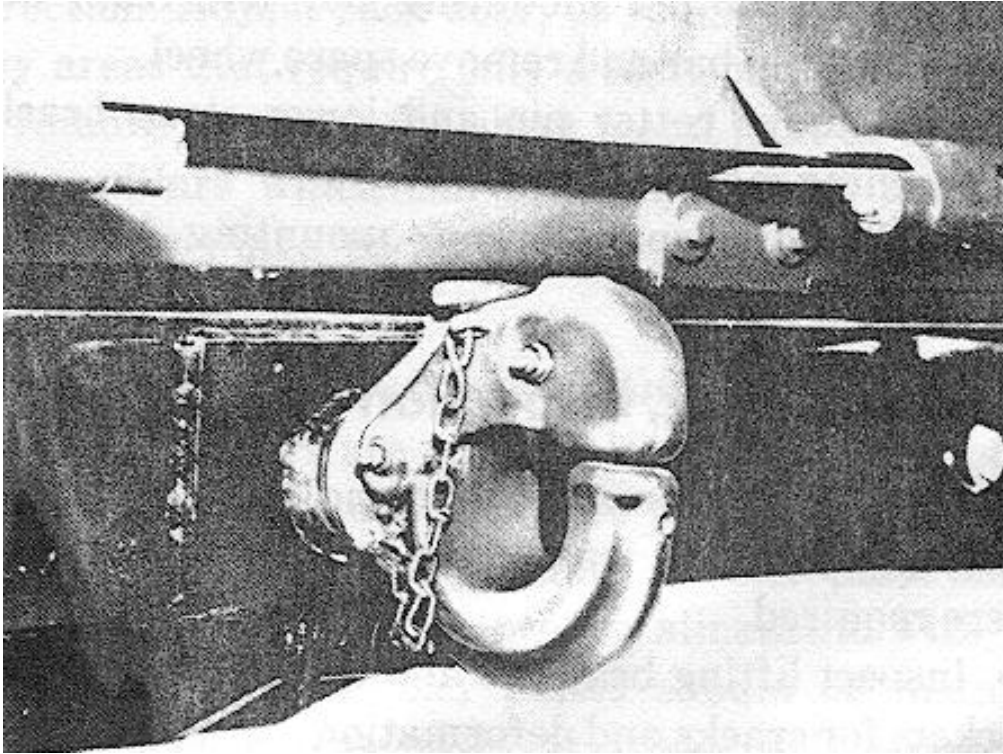

Figure 2-91. Rear pintle hook.

b. Towing Shackles. (Fig 2-92)

- (1) Remove cotter pin from shackle pin and remove shackle pin from bracket.
- (2) Remove shackle from bracket.
- (3) Remove four nuts, lock washers and bolts which secure rear towing shackle assembly to rear crossmember and remove shackle assembly.

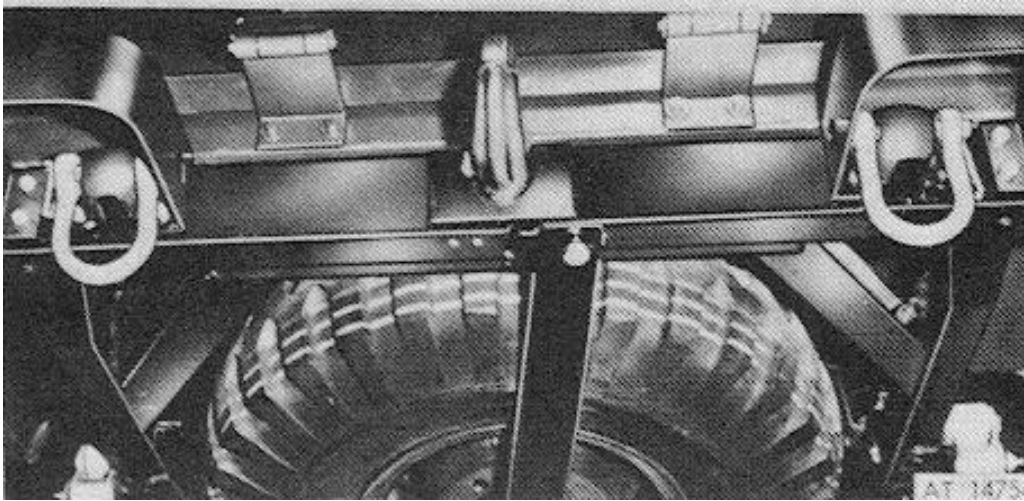

Figure 2-92. Towing shackles.

c. Lifting Brackets.

- (1) Remove four nuts and lockwashers which secure lifting brackets to rear wheels and remove brackets.
- (2) Remove four nuts and lock washers which secure lifting brackets to front wheels and remove brackets.

d. Front Bumper.

- (1) Remove towing shackles as described in (bi above).
- (2) Remove remaining nuts, lock washers and bolts which secure bumper to frame front and remove bumper.

e. Rear Bumperettes. Remove five nuts, lock washers and bolts which secure bumperettes to rear cross-member and remove rear bumperettes.

f. Spare Tire Wheel Carrier. (Fig 2-93)

- (1) Loosen spare wheel mounting bar bolt attached to rear frame crossmember.
- (2) Slide slotted mounting bar left from bolt; lower mounting bar and remove spare wheel.
- (3) Remove cotter pin and lower strap bracket pin attaching mounting bar.
- (4) Remove spare wheel mounting bar from vehicle.

2-114. Cleaning, Inspection and Repair.

- a. Clean dirt, corrosion, rust and loose paint from front bumper and rear bumperettes. Spot paint where required.
- b. Inspect lifting brackets and towing shackles and brackets for cracks and deformation.
- c. Clean and lightly oil threads of all attaching bolts and nuts.

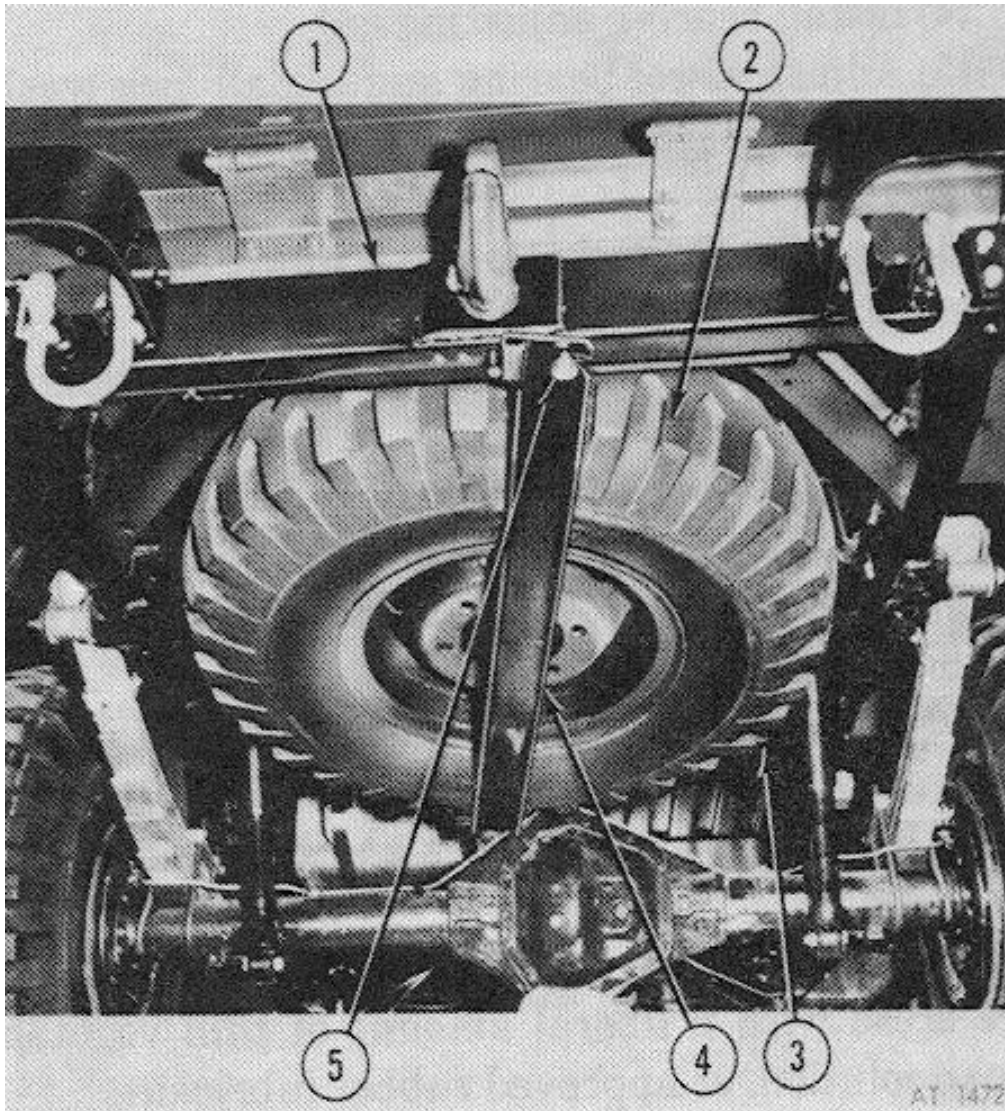

Figure 2-93. Spare tire stowed.

- 1 Rear crossmember
- 2 Spare tire
- 3 No. 4 crossmember
- 4 Retaining strap
- 5 Retaining bolt

2-115. Installation.

- a. Rear Bumperettes. Position rear bumperettes on rear crossmember and install attaching bolts, lock washers and nuts. Tighten to 50-75 lbs-ft.
- b. Front Bumper

(1) Position front bumper and install attaching bolts, lock washers and nuts. Tighten to 20-35 lbs-ft.

(2) Position towing shackles through opening in front.

(3) Install shackle pin into frame and secure with cotter pin.

c. Lifting Brackets.

(1) Position lifting brackets on front and rear wheels.

(2) Install four lock washers and nuts and tighten.

d. Towing Shackles. (Fig 2-92)

(1) Position rear towing shackle plates on rear crossmember. Install four bolts, lock washers and nuts; tighten to 80-120 lbs-ft. torque.

(2) Install shackle on bracket and insert shackle pin through shackle and bracket.

(3) Install cotter pin in shackle pin.

e. Pintle. Install pintle hook through mounting plates. Install washer, slotted nut. Tighten securely and install cotter pin.

f. Spare Tire Wheel Carrier. (Fig 2-93)

(1) Position mounting bar on frame strap bracket and install retaining pin, washer and cotter pin.

(2) Install spare wheel onto mounting bar: raise mounting bar and attach to bolt.

(3) Tighten bolt securing spare wheel.

Section XXVII. MAINTENANCE OF CAB AND BODY

2-116. General.

a. The cargo truck open cab consists of a reinforced rear panel and sill, a floor panel, cowl and dash panel, cowl ventilator and left and right door openings. The door pillars have provisions for installing the door and window kit. A hardtop is also available that may be installed in place of the cab soft top.

b. The cargo truck body is equipped to carry eight personnel with their equipment and arms. Protection from the elements for passengers and/or cargo is provided.

c. The ambulance body is constructed of sheet metal panels welded together forming the cab compartment and patient compartment. The two compartments are separated by a bulkhead with sliding door to allow passage of the attendant from the cab to the ambulance body. Refer to the Operator's Manual for description of ambulatory patient carrying capability.

d. Ventilation blowers are mounted in the left and right forward upper corners of the ambulance body and are controlled by individual upper corners of the ambulance body and are controlled by individual switches located on the bulkhead panel. Refer to the Operator's Manual for operational instructions.

e. The ambulance body heater is located under the seat in the left front corner of the patient compartment. The heater compartment is completely sealed against entry of water and dust. The air intake and exhaust outlets are located in the outer side panels.

f. Individual circuit breakers are mounted behind access plate, at left side of bulkhead, for the spotlight, heater, resuscitator electrical outlet, heater fuel pump, left and right ventilation blowers and the surgical lamp.

2-117. Maintenance and Adjustment.

Refer to the Operator's Manual for daily maintenance instructions. Refer to the lubrication order for periodic lubrication services and prescribed lubricant for all temperature ranges.

a. Body Sealing. In most cases, a visual inspection of an area will indicate the need for sealing. When testing with water, use a spray simulating rain or a garden hose without the nozzle and regulate the pressure to an approximate 3-inch stream. All water tests must be made starting at the bottom of the door opening or weatherstrip and slowly move up the joint, seam or suspected area. In some cases, it is advisable to use trace powder and a test bulb to test the sealing between the body and the weatherstrips. When the powder is sprayed at the point where a leak is suspected, it will leave a trace line through the point of leakage.

(1) Interior. A light source, or compressed air stream, under the vehicle will help in determining openings where dust and water may enter the vehicle. It is suggested that all weld joints, seams and holes (except those required for drainage) be checked and sealed, noting especially the following areas:

- (a) The vertical joints between the cowl inner side panel and the firewall and floor pan. Check all openings in cowl inner side panels for hole plugs and grommets. Seal all openings.
- (b) Check all visible holes in the firewall. Check for an open hole in the accelerator bracket area. Check horizontal joints of upper cowl panels. Check seal of steering column cover plate on firewall.
- (c) Check for any open holes, loose screws, etc., in the floor pan in the seat area. Check and seal transmission cover in floor pan.
- (d) Check the rear of the floor pan for open holes and loose screws.

(2) Engine compartment. Examine the firewall for openings. Seal as necessary. Add sealer to grommets where wiring and control cables pass through firewall.

(3) Doors. Check the condition of the weatherstrip on each door. Cement it to the door if loose; replace if damaged. Test the effectiveness of the door weatherstrip by inserting a strip of paper (approximately 1-inch x 15-inches) in the door opening, and closing the door securely. Then pull out the strip of paper. A moderate pull indicates an effective seal at that point. Do this at several points around the door opening. A light pull at one point in the door indicates the need for door adjustment in that direction. Adjust each door, as required, to eliminate any areas that require only a light pull on the paper to remove it. Check the sheet metal joint at the front hinge pillars which can be seen through the lower front door hinge pockets. Seal any openings in the joints.

b. Front Door Adjustments (Cargo Truck).

(1) The doors are adjustable at the hinge mounting points on the door and the body. The door lock striker plate is also adjustable. Striker plate shims are available to ensure proper alignment with the door lock. Also, striker plates should be installed so door lock enters freely and door will remain in closed position.

(2) These adjustments are adequate to obtain proper door alignment and adjustment under normal circumstances.

(3) Floating plates located in the door panel and elongated holes in the hinge cage permit adjustment in all directions.

c. Front Door Adjustments (Ambulance).

(1) The door lock strikers, hinges, dovetails and weatherseals must be correctly adjusted to ensure proper closing and sealing of the doors.

(2) If it is necessary to adjust the cab doors, loosen the screws at both door hinges and position the door all four ways in the opening.

(3) Tighten all screws, adjust lock striker plate and dovetail if necessary.

(4) To adjust the striker, loosen the two lock washer screws that secure the striker to the lock pillar and move the striker in or out, as required.

(5) To adjust the dovetail, loosen the two lock washer screws that secure the male dovetail to the lock pillar and move the dovetail up or down, as required.

(6) Tighten the screws after making the adjustments.

(7) If the door is replaced, the door check arm pin must be removed.

d. Rear Door Adjustment (Ambulance).

(1) Close the double doors and be certain the weatherseals contact.

(2) Loosen the two cap screws at each end of the three hinges on each door and on each hinge pillar. The hinges are held in place on the body by a sliding adjustable hinge plate.

(3) Adjust the door both vertically and horizontally and tighten the cap screws at each end of each hinge.

e. Tailgate Adjustment. Tailgate adjustment is accomplished by the following:

(1) Straightening tailgate.

(2) Straightening cargo sides.

(3) Straightening tailgate latching brackets.

(4) Adjusting hinges.

f. Bulkhead Door Adjustment (Ambulance). (Fig 2-94)

(1) The bulkhead door is a sliding door on the inside of the cab. The double catch on the door engages on the right in the closed position or on the left in the

open position.

(2) Adjust the bulkhead door by raising or lowering the two nylon roller brackets located at bottom of door.

(3) Loosen the nuts securing the brackets to the door, and adjust brackets upward or downward until door slides freely in the track. Hold this adjustment, then tighten the nuts.

(4) To remove the bulkhead door, lift up and pull out from the bottom when door is in the closed position, unlatched.

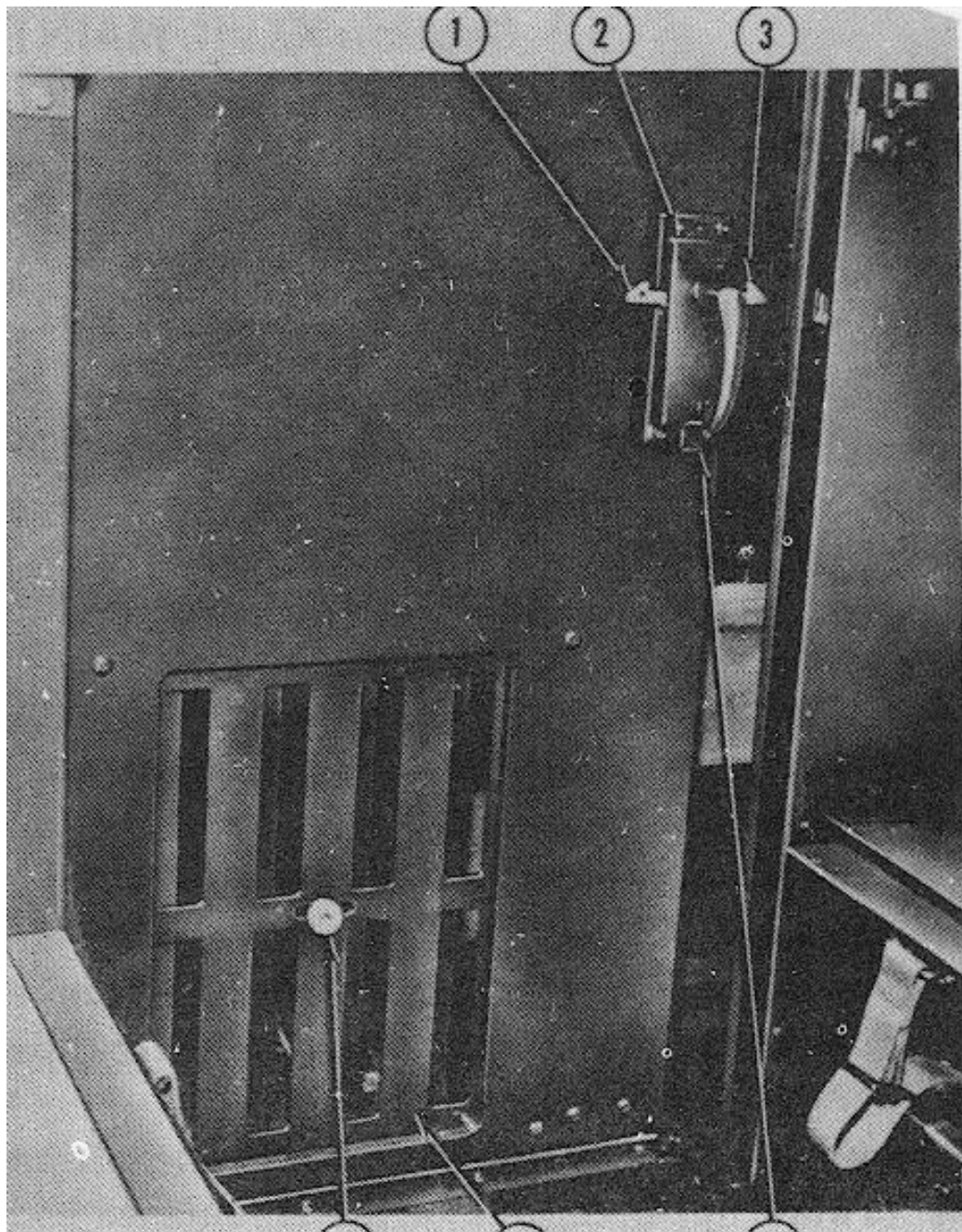



Figure 2-94. Bulkhead door.

- 1 Door open catch
- 2 Door lock assembly
- 3 Door close catch
- 4 Door lock lever
- 5 Air inlet panel
- 6 Air inlet control knob

2-118. Removal.

a. Grille Guard. (Fig 2-95)

- (1) Remove bolts securing upper grille guard support straps to grille panel and radiator support assembly.
- (2) Remove bolts securing lower grille guard rail to left and right side of the grille panel and radiator support assembly.
- (3) Remove grille guard assembly.

b. Hood panel and Hood Hinge. (Fig 2-96)

- (1) Unlatch both the left and right hood retaining latches and raise the hood to the full open position. Disconnect the blackout driving light wire harness.
- (2) Before removing the hood panel, scribe the position of the hinge on the hood reinforcement if the hood panel is correctly aligned. If the hinges are to be removed preparatory to taking off the complete front end assembly, scribe the position of the rear face of each hinge on the firewall and the position of each hinge side on the fender apron bracket.
- (3) Detach the hood panel from the hinges by removing the bolts, lock washers and flat washers securing the hood to the top of the hinges. Lift the hood panel off the hinges.
- (4) If the hood panel is being removed in preparation of removing the complete front end assembly, remove the hood hinges, once the hood panel is off, by removing the bolts, lock washers and washers securing the hinges to the firewall and to the fender apron bracket.

c. Windshield. (Fig 2-97)

- (1) Unsnap cab soft top from corners of windshield frame.
- (2) Disconnect windshield wiper vacuum hose at windshield wiper motor.
- (3) Disconnect vacuum hose from clips attached at windshield wiper frame.
- (4) Remove two pivot bolts which secure windshield left and right hinges to cowl panel.
- (5) Disconnect left and right windshield clamps from instrument panel.
- (6) Lift windshield up to disengage hinge bolts from cowl panel and remove windshield assembly, sliding soft top from windshield channel.

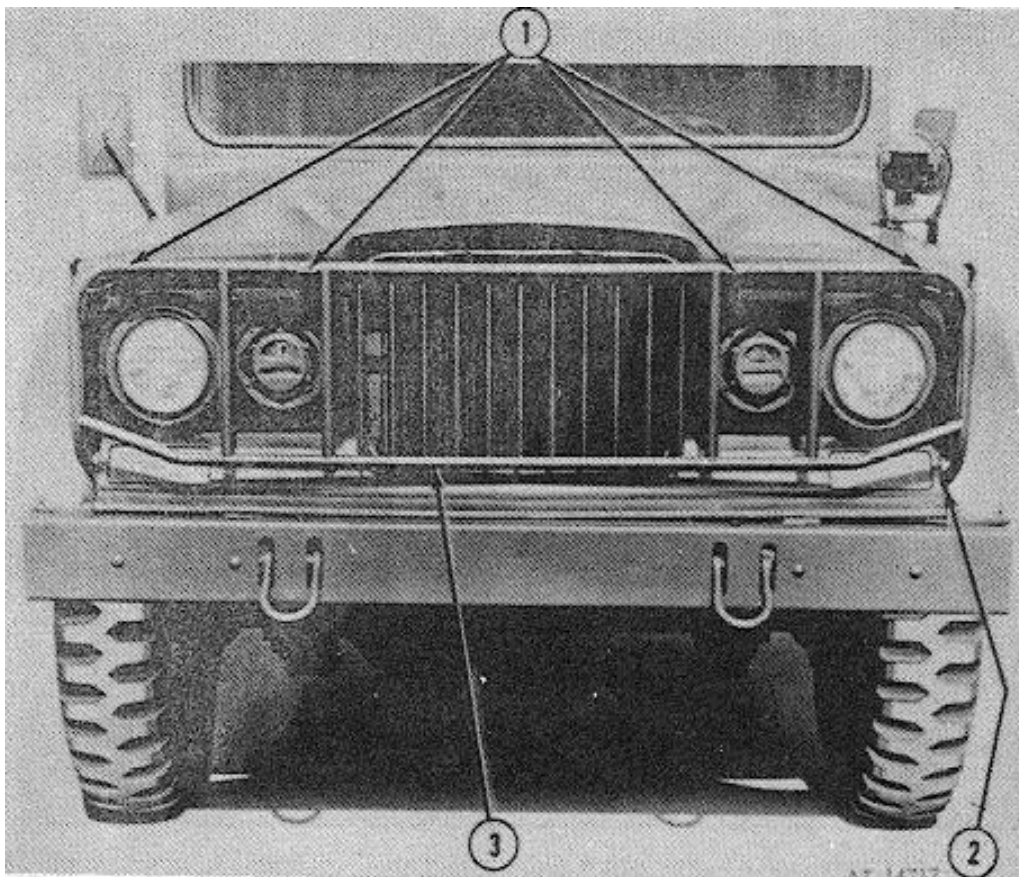

Figure 2-95. Grille guard removal.

- 1 Upper bolt
- 2 Lower bolt
- 3 Grille guard

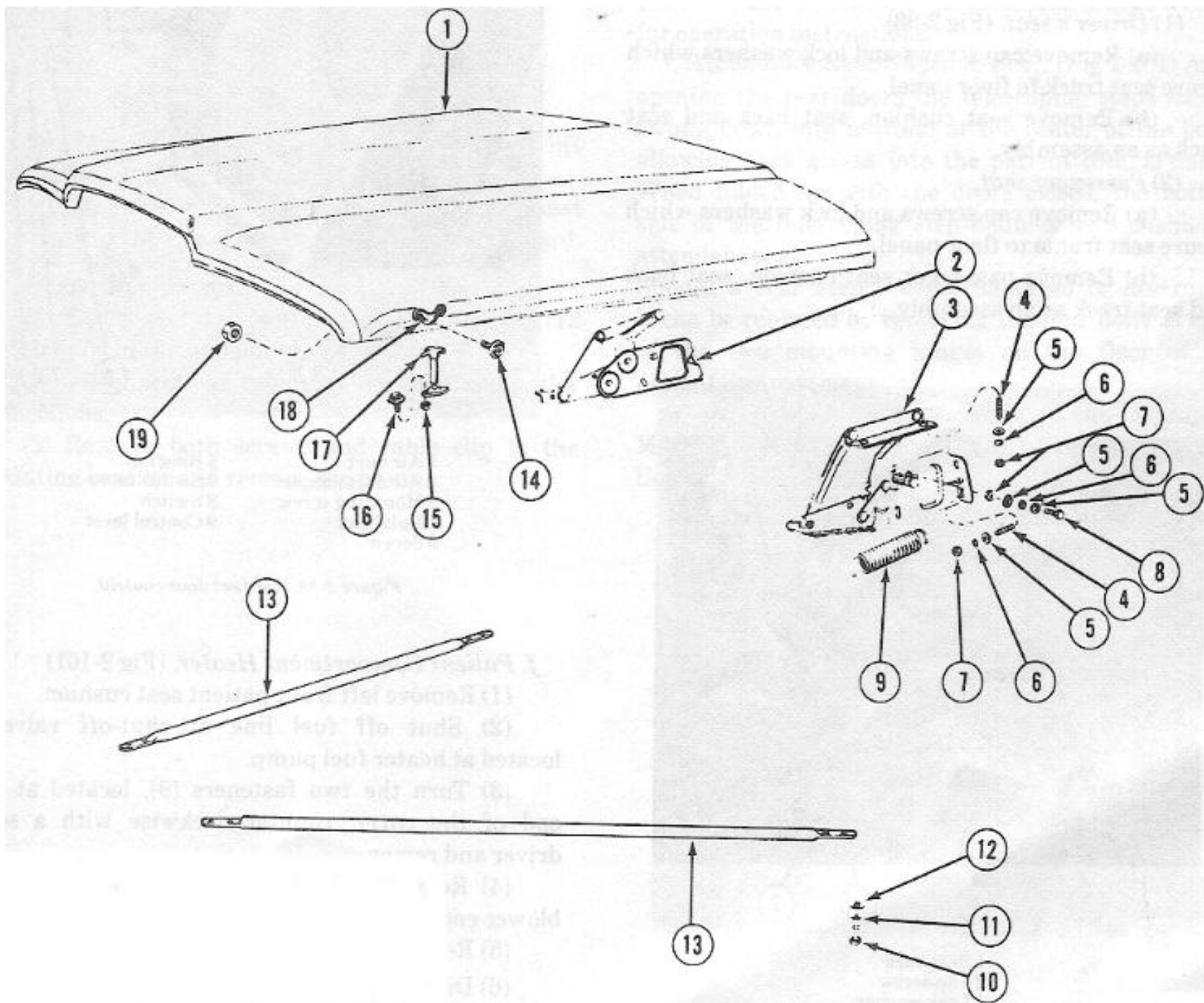

Figure 2-96. Hood panel and attaching parts.

1 Hood	11 Lock washer
--------	----------------

2 Right hinge	12 Flat washer
3 Left hinge	13 Brace
4 Stud	14 Screw and washer assembly
5 Flat washer	15 Nut
6 Lock washer	16 Bolt and washer assembly
7 Nut	17 Latch
8 Bolt	18 Catch
9 Spring	19 Nut
10 Bolt	

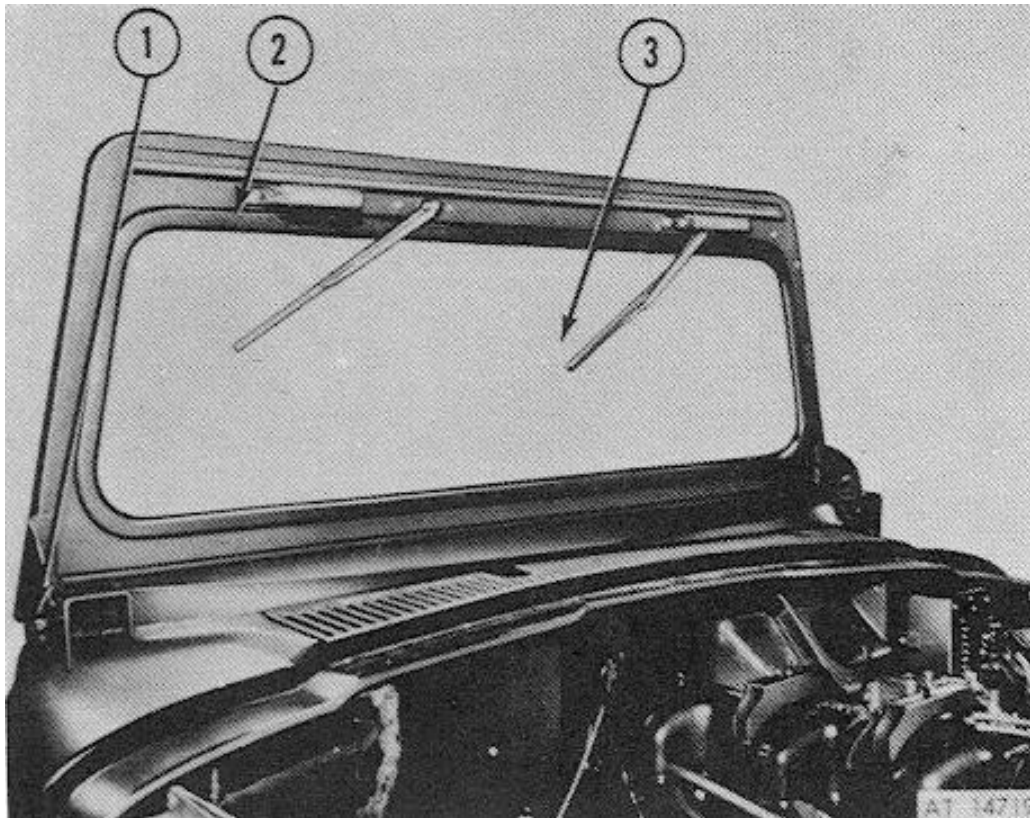

Figure 2-97. Windshield removal.

- 1 Pivot bolt
- 2 Windshield seal
- 3 Windshield glass

d. Seat and Seat Cushions.

(1) Driver's seat. (Fig 2-98)

(a) Remove cap screws and lock washers which secure seat track to floor panel.

(h) Remove seat cushion, seat back and seat track as an assembly.

(2) Passenger seat.

(a) Remove cap screws and lock washers which secure seat frame to floor panel.

(b) Remove passenger seat cushion, seat back and seat track as an assembly.

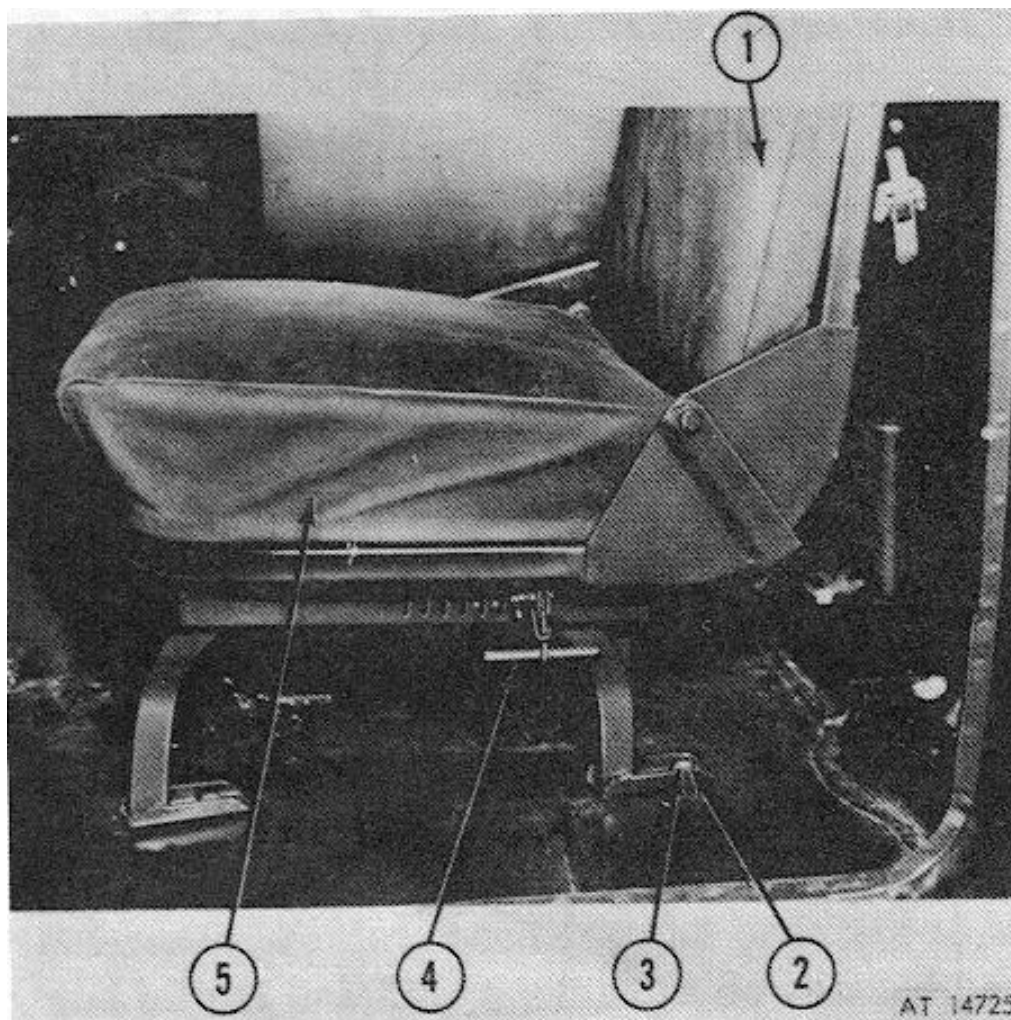

Figure 2-98. Driver's seat.

1 Seat back

2 Cap screw

3 Lock washer

- 4 Adjusting handle
- 5 Seat cushion
- 6 Ring nut
- 7 Switch cover
- 8 Switch
- 9 Control lever

e. Exhaust Fan Assembly. (Fig 2-100)

- (1) From cab side, remove the triangular fan cover.
- (2) From the patient compartment side, remove the rear vent duct cover (fig 2-99).
- (3) Disconnect the wire harness connectors.
- (4) Remove the three cap screws holding the fan and motor to the bulkhead and the two cap screws holding the motor to the side wall. (Fig 2-100)
- (5) Remove motor assembly.

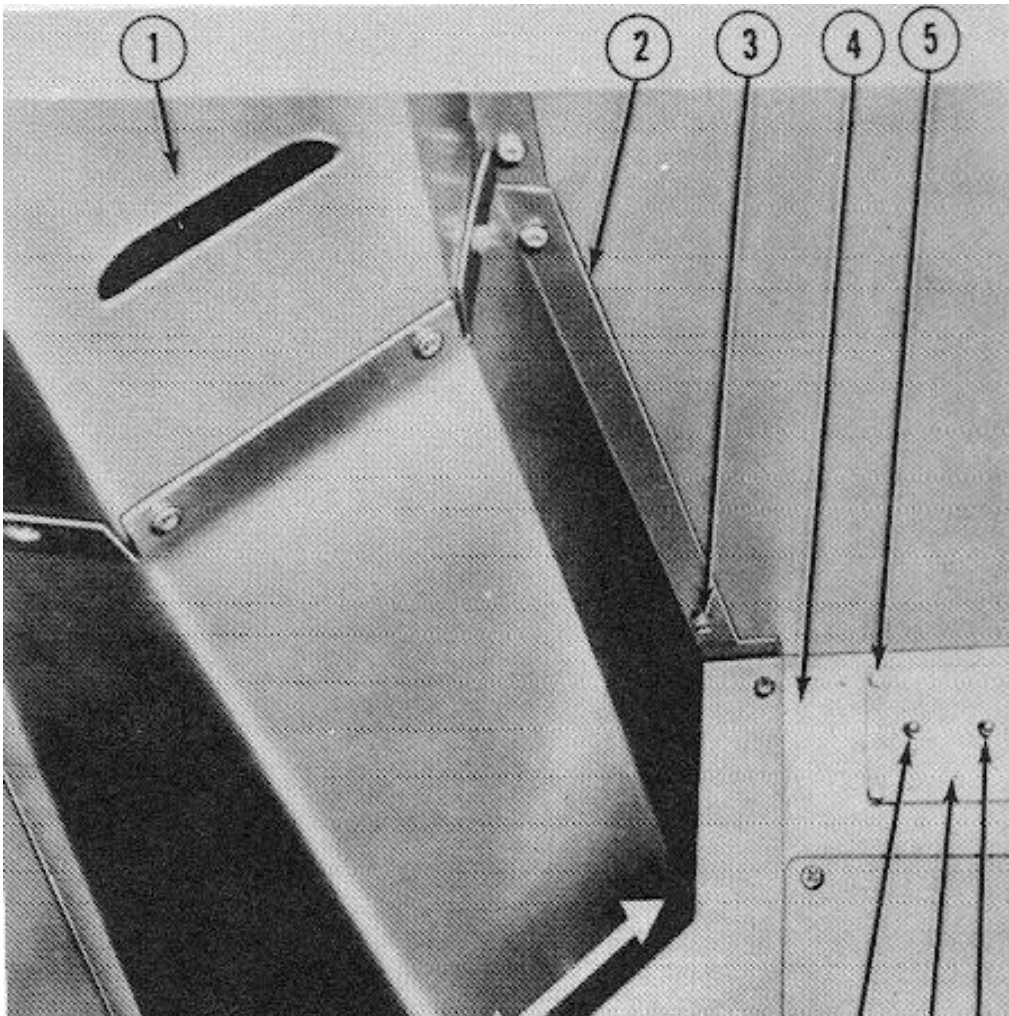

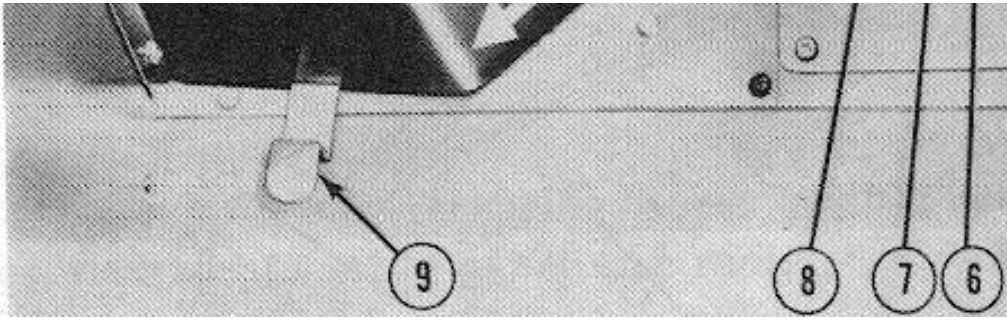

Figure 2-99 Air duct door control

- 1 Air duct
- 2 Air duct adapter
- 3 Mounting screw
- 4 Bulkhead
- 5 Screw

f. Patient Compartment Heater. (Fig 2-101)

- (1) Remove left front patient seat cushion.
- (2) Shut off fuel line at shut-off valve (3) located at heater fuel pump.
- (3) Turn the two fasteners (9), located at each end of the cover, counter-clockwise with a screw driver and remove.
- (4) Remove the two holddown bolts (7), at the blower end.
- (5) Remove the holddown clamp at the other end,
- (6) Disconnect the clamp (13) on the large flexible duct at the heater.
- (7) Disconnect the wire harness connector (12).
- (8) Disconnect the fuel inlet line at the fuel shutoff valve on the heater.
- (9) Pull the heater towards the front and lift up to disengage from the exhaust outlet.
- (10) Remove the O-ring gasket from the exhaust extension at the underside of the heater and discard.

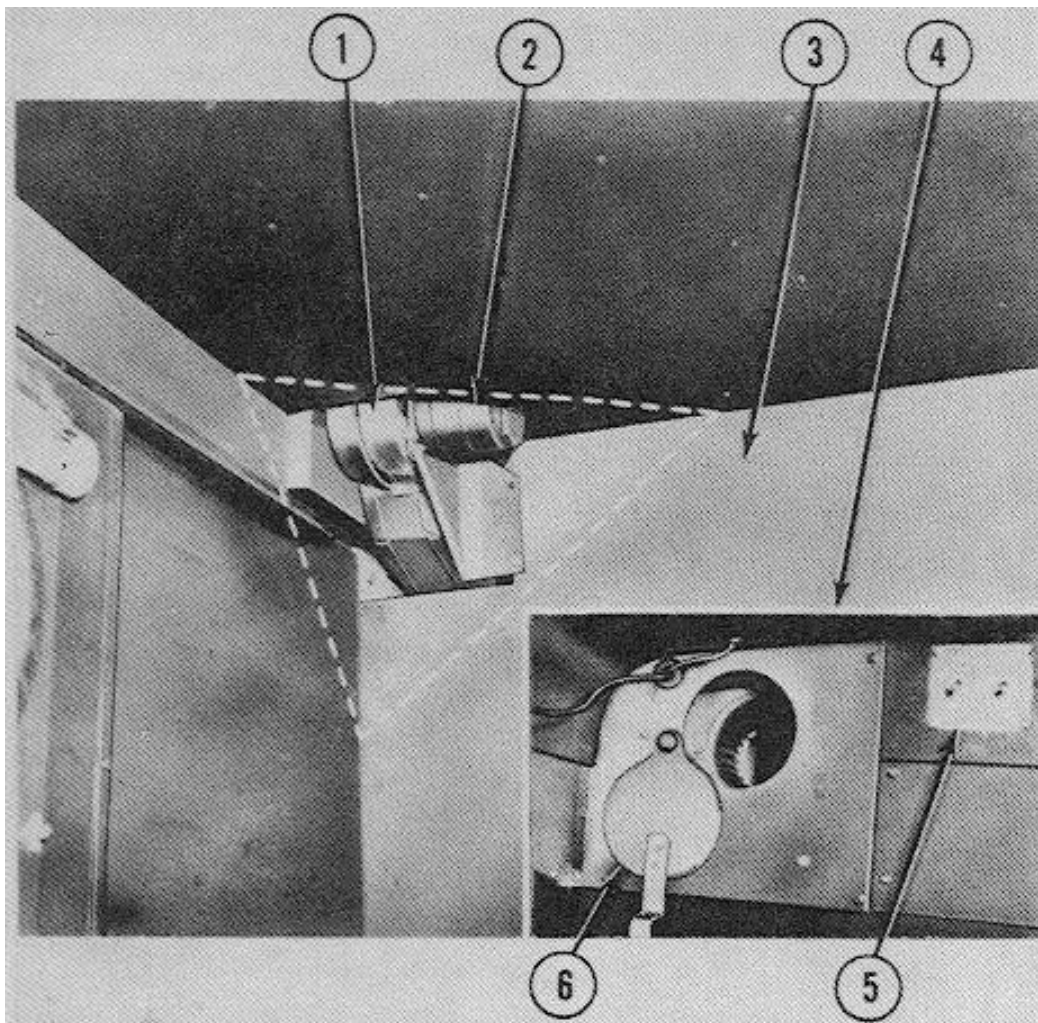

Figure 2.100. Exhaust fan assembly

- 1 Fan housing
- 2 Motor
- 3 Cab side wall
- 4 Bulkhead
- 5 Switch plate
- 6 Air control door

g. Heater Fuel Pump.

- (1) Disconnect the wire harness connector (12 fig 2-101) from the fuel pump.
- (2) Disconnect the tubing at the inlet and outlet connections.
- (3) Remove both screws and cable clip to the mounting bracket and remove the pump.

h. Heater Switch Control Panel (Ambulance Only).

- (1) Disconnect battery cable from battery negative terminal.
- (2) Remove screws which secure control panel to ambulance compartment bulkhead panel.
- (3) Pull control panel away from bulkhead panel.
- (4) Disconnect wiring harness cable connectors from switch, thermostat and circuit breakers.

L Outside Stowage Compartment Handle. (Fig 2-102)

- (1) Loosen the set screw on the U-shaped latch and remove from the square shaft.
- (2) Remove the handle from the front of the door.

j. Rear Door Blackout Curtain (Ambulance). (Fig 2-103)

- (1) Unfasten the two straps that hold the curtain in the rolled up position, lowering the curtain.
- (2) Remove four screws holding the curtain retainer strip in place. Remove curtain.

k. Litter Racks.

Refer to the Operator s Manual, TM 9-2320-244-10, for operation instructions.

l. Ambulance Rear Step and Seat. (Fig 2-104) After opening the rear doors the telescoping steps can be swung down into position at the center of the body, allowing easy access into the patient compartment. When folded up with the doors closed, the bottom side of the telescoping step doubles as a cushioned attendant seat. Should a rear step become damaged or destroyed, it can be replaced by removing the four bolts at each of the two mounting hinges on the floor of the patient compartment.

m. Straps and Brackets. Refer to the Operator s Manual, TM 9-2320-244-10, for utilization instruction.

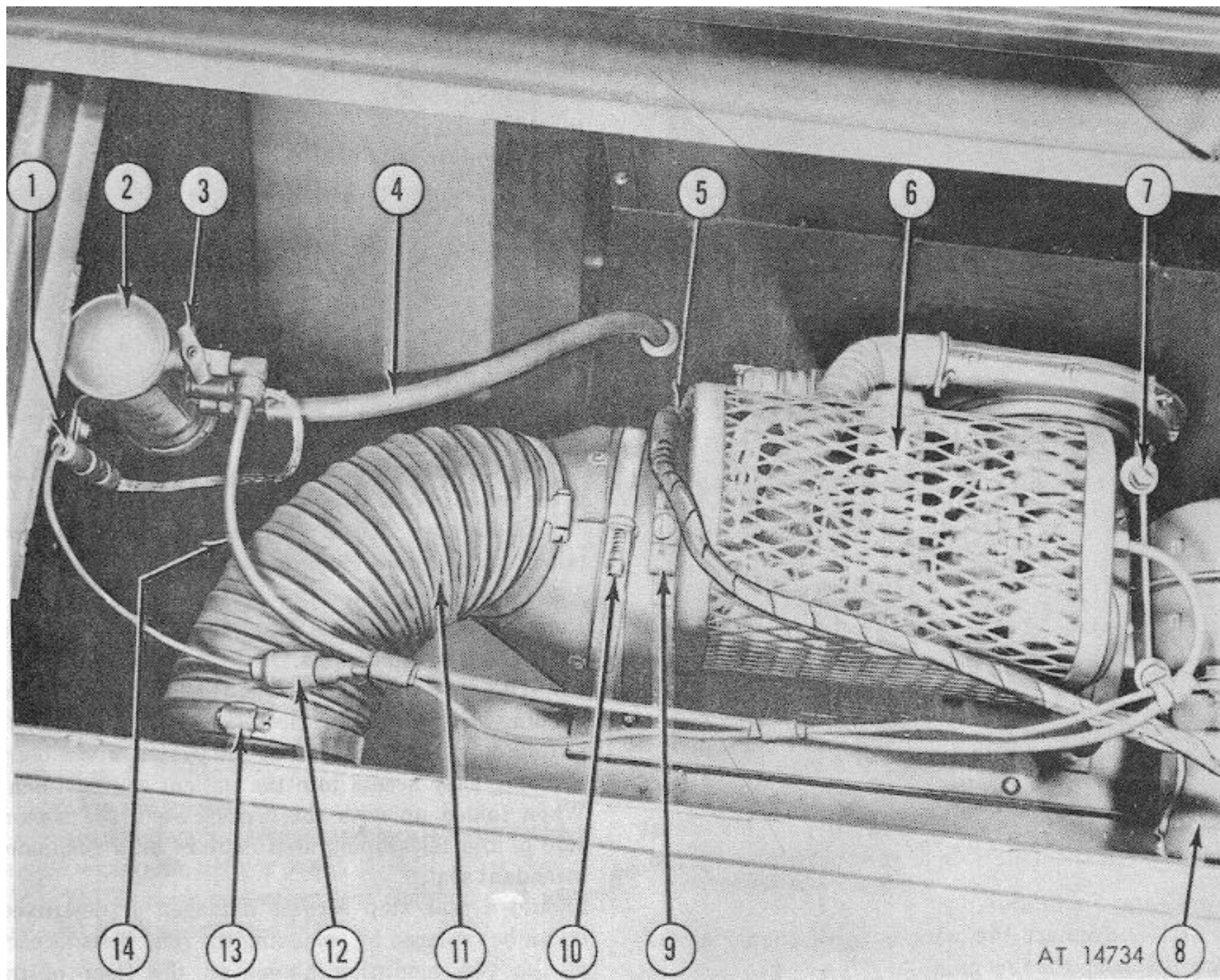

FIGURE 2-101. Patient Compartment Heater.

1 Condenser

8 Heater motor and blower

2 Fuel pump	9 Cover fastener
3 Shut off valve	10 Mounting clamp
4 Fuel inlet line	11 Flexible hose
5 Heater wiring cable	12 Wire harness connector
6 Heater assembly	13 Flexible hose clamp
7 Mounting clamp and bolt	14 Fuel outlet line

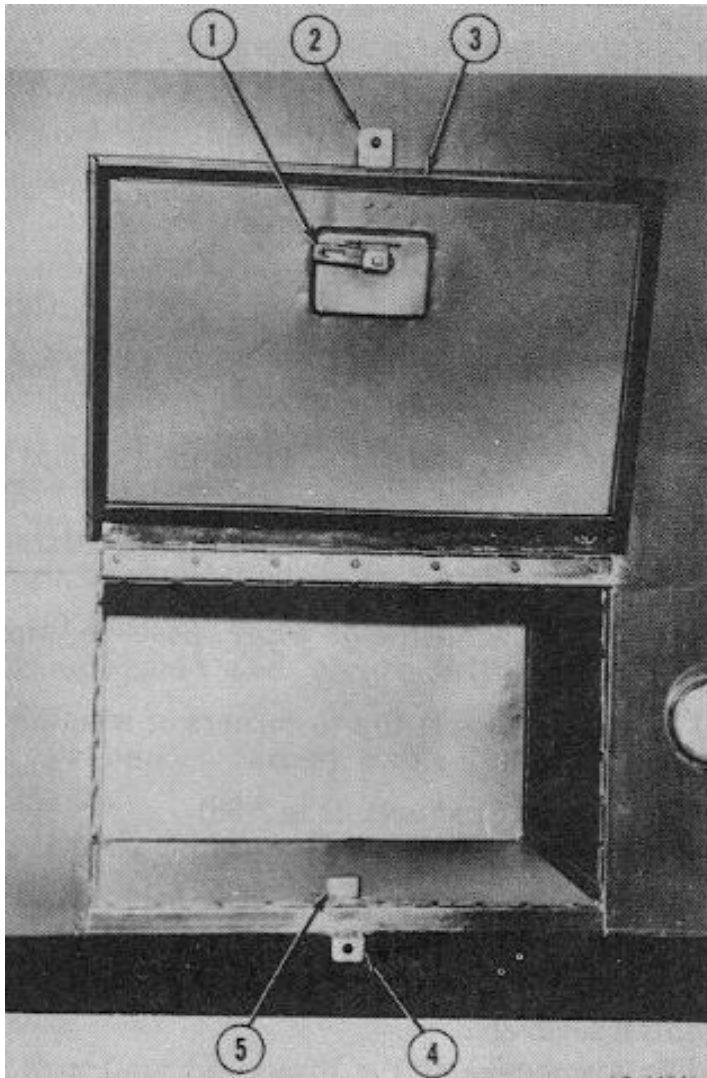

Figure 2-102. Outside stowage compartment.

- 1 Latch bar
- 2 Door lock bracket

- 3 Door seal
- 4 Body lock bracket
- 5 Latch bracket

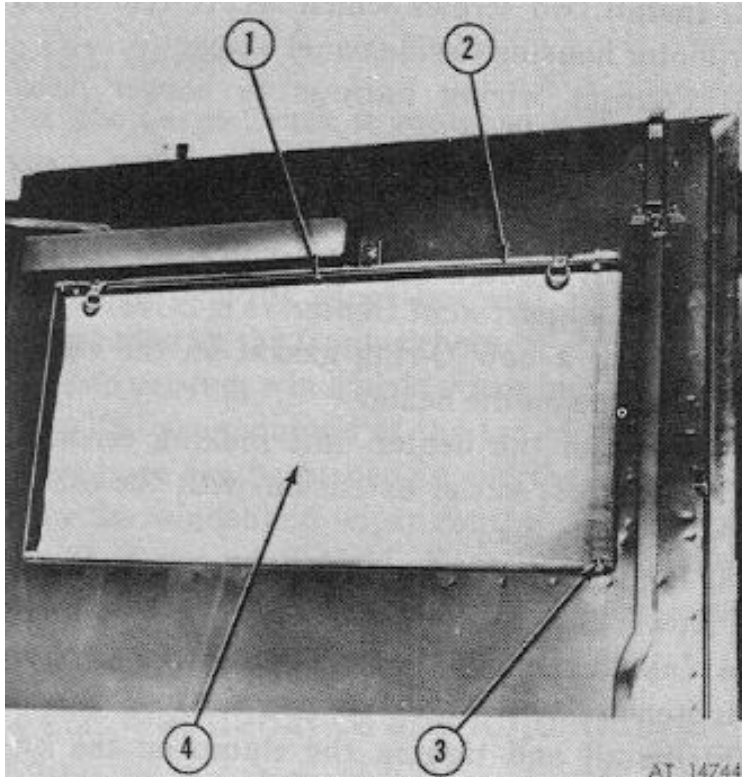

FIGURE 2-103. Rear door blackout curtain.

- 1 Retaining screw
- 2 Retainer bar
- 3 Pile and loop lock strip
- 4 Blackout curtain

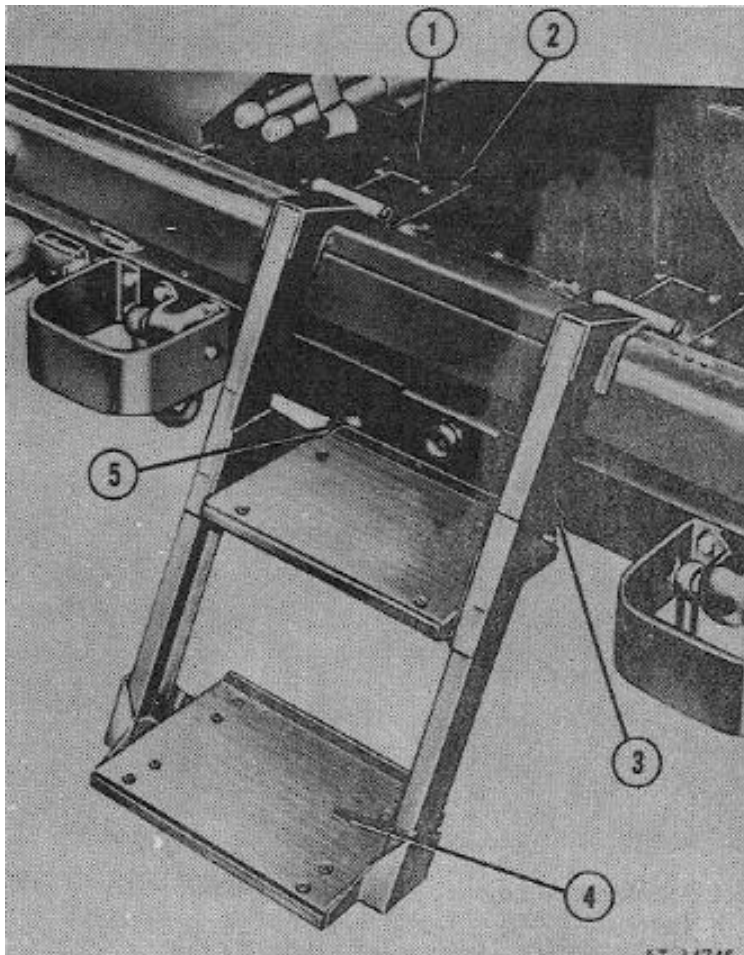

Figure 2-104. Rear step assembly.

- 1 Hinge
- 2 Hinge screw
- 3 Side rail
- 4 Step
- 5 Rubber bumper

n. Doors.

- (1) Remove two upper hinge-to-hinge pillar bolts.
- (2) Support door and remove two lower hinge-to-hinge pillar bolts and remove door assembly.

o. Rear Door Locks and Latches. (Fig 2-105)

- (1) Remove two cotter pins securing latch rods to top and bottom door locks.
- (2) Remove flat washers, latch rod ends and spring washers from pins to lock assembly.
- (3) Remove four screws securing latch to rear door panels.
- (4) Remove door locks and latches from rear doors.

p. Tailgate.

- (1) Remove four cotter pins securing hinge pins.
- (2) Remove the four hinge pins securing upper and lower hinge halves.
- (3) Unhook chain retainer on each side of tailgate.
- (4) Remove tailgate.

2-119. Cleaning and Inspection.

- a. Inspect top bows, side bows, and ridge pole for breaks, and bow corners and ridge pole brackets for damage.
- b. Inspect body cover and end curtains for wear, damage and deterioration. Inspect tie down ropes for wear and damage.
- c. Inspect safety straps for tears or damaged fasteners.
- d. Inspect blackout curtains for tears.
- e. Inspect windshield frame for cracks, torn metal. Inspect hold-open clamps for cracked or deformed brackets.
- f. Clean and lightly oil threads of all attaching bolts and nuts.

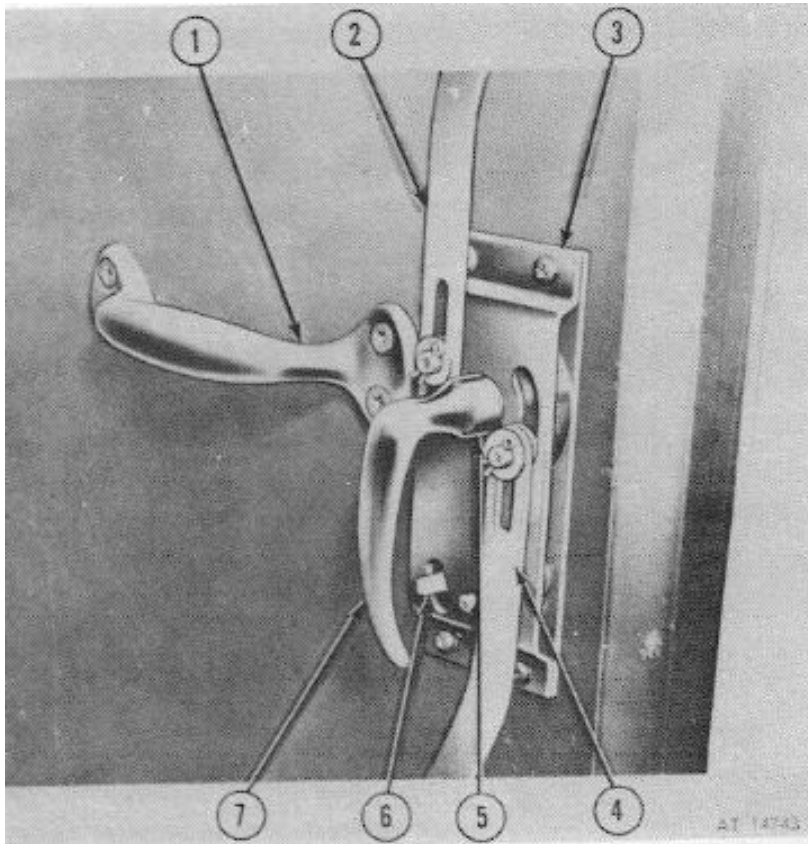

Figure 2-105. Rear door lock and latches.

- 1 Door inner handle
- 2 Upper latch bar
- 3 Lock assembly
- 4 Lower latch bar

- 5 Handle drive pin
- 6 Locking lever
- 7 Lock inner handle

2-120. Installation.

a. Grille Guard. (Fig 2-95)

- (1) Position grille guard onto vehicle.
- (2) Install bolts securing lower grille guard rail to left and right side of grille panel and radiator support assembly. Tighten bolts securely.
- (3) Install bolts securing upper grille guard support to grille panel and upper radiator support assembly.

b. Hood Panel and Hood Hinge. (Fig 2-96)

- (1) Install hood hinges by positioning the hinges to the firewall and fender apron brackets.
- (2) Install and lightly tighten the bolts, lock washers and flat washers securing hinges to the firewall and apron brackets.
- (3) Aline hinges to the scribe marks and torque tighten bolts.
- (4) Set hood hinges in full hood-open position, place hood in position and lightly tighten the flat hood hinges.
- (5) Aline hood to hood hinge scribe marks and torque tighten the bolts,
- (6) Connect blackout driving light wire.
- (7) Torque tighten all bolts securing hood and hood hinges from 12 to 15 lbs-ft.

c. Windshield. (Fig 2-97)

- (1) Slide soft top into windshield channel.
- (2) Install windshield-to-cowl panel hinge bolts. Tighten bolts.
- (3) Connect left and right windshield clamps to instrument panel.
- (4) Position vacuum hose behind clips attached at windshield wiper frame.
- (5) Connect windshield wiper hose to wiper motor.
- (6) Re-snap cab soft top to corners of windshield frame.

d. Seat and Seat Cushions. (Fig 2-98)

- (1) Driver's seat.
 - (a) Position seat cushion, seat back and seat track assembly on floor panel.
 - (b) Install four attaching bolts and lock washers. Tighten securely.
- (2) Passenger seat.
 - (a) Position seat frame on floor panel.
 - (b) Install four bolts and washers which secure seat frame to cab floor panel.
- (c) Tighten all bolts securely.

e. Exhaust Fan Assembly. (Fig 2-100)

- (1) Position blower motor housing to ambulance body front panel and install screws. Tighten securely.
- (2) Install two screws which secure rear end of blower motor housing to side panel bracket.
- (3) Connect wiring harness to blower motor terminals.
- (4) Position forward portion of ventilation duct and install sheet metal screws which secure duct to ambulance body front, roof and side panels.

f. Patient Compartment Heater. (Fig 2-101)

- (1) Install a new 0-ring gasket on the exhaust outlet extension on the heater.
- (2) Position the heater unit making certain to aline the exhaust outlet extension with the exhaust outlet pipe in the floor.

- (3) Replace the two hold-down bolts and clamp at the blower end.
- (4) Install the hold-down clamp at the other end and tighten.
- (5) Install and tighten the clamp on the large flexible duct.
- (6) Connect the wire harness connector.
- (7) Connect and tighten the fuel line.
- (8) Start the heater according to the operating instructions and run for a few minutes.
- (9) Stop the unit. Replace the cover and turn the two fasteners clockwise with a screwdriver to tighten.

g. Heater Fuel Pump.

- (1) Adjust the fuel pump in the mounting bracket and tighten the two screws.
- (2) Connect the inlet and outlet tubing.
- (3) Connect the wire harness connector (12 fig 2-101).

h. Heater Switch Control Panel (Ambulance Only).

- (1) Position heater switch, thermostat and circuit breakers in control panel and install attaching screws and washers.
- (2) Connect wiring harness cable connectors to switch, thermostat and circuit breakers.
- (3) Position control panel to ambulance body bulkhead panel and secure with eight attaching screws.
- (4) Connect battery cable to battery negative terminal.

i. Outside Stowage Compartment Handle. (Fig 2-102)

- (1) Install handle onto square shaft.
- (2) Install set screw on the U-shaped latch and tighten.

j. Rear Door Blackout Curtain (Ambulance). (Fig 2-103)

- (1) Position curtain on rear door.
- (2) Install retaining strip and secure with screws.
- (3) Roll curtain up and fasten with two retaining straps.

k. Litter Racks. Refer to Operator s Manual, TM 9-2320-244-10, for operation instructions.

l. Ambulance Rear Step and Seat. (Fig 2-104)

- (1) Position and aline rear step and seat hinges to holes in the floor patient compartment.
- (2) Install eight bolts and secure the two hinges to the floor of the patient compartment. Tighten bolts securely.

m. Straps and Brackets. Refer to Operator s Manual, TM 9-2320-244-10, for utilization instructions.

n. Doors.

- (1) Support door and install the two lower hinge-to-hinge pillar bolts. Do not tighten bolts.
- (2) Install the two upper hinge-to-hinge pillar bolts.
- (3) Adjust door to cab opening and tighten bolts.

o. Rear Door Locks and Latches. (Fig 2-105)

- (1) Position locks and latches on rear door and secure with screws.
- (2) Install spring washers, latch rod ends and flat washers onto the lock assembly pins and secure with cotter pins.

p. Tailgate.

- (1) Position tailgate to cargo body.
- (2) Aline hinges and install all four hinge pins.
- (3) Secure four hinge pins with four cotter pins.
- (4) Raise tailgate and fasten the securing chain to each side of tailgate.

Section XXVIII. MAINTENANCE OF BODY CHASSIS AND ACCESSORY ITEMS

2-121. General.

- a. The Cargo Truck is equipped with a removable canvas soft top over the driver s compartment and cargo area.
- b. Red reflectors are mounted on the left and right rear corners of the cargo box and amber reflectors are mounted on the front corners.
- c. Two vacuum windshield wiper motors and wipers (fig 2-106) are mounted at the top of the windshield. Both wipers can be turned on and their speed adjusted by the windshield wiper control at tne upper left corner of the windshield. Each wiper blade can be operated manually by means of a lever located on each motor.

2-122. Maintenance and Adjustment.

Refer to the Operator s Manual, TM 9-2320-244-10, for daily maintenance instructions.

2-123. Removal.

a. Cargo Cover, End Curtains and Bows.

- (1) Detach cargo cover ropes from body, front and side panels.
- (2) Roll sides up and remove cargo cover and front and rear end curtains.
- (3) Remove nut, lock washer and bolt which secures each roof bow to cargo box side channels.
- (4) Remove roof bows and ridge pole as a unit.
- (5) Remove ridge poles from roof bows.

b. Cab Soft Top. Refer to TM 9-2320-244-10 for canvas top removal procedures.

c. Rear View Mirrors and Brackets.

- (1) Remove nut and flat washer which secure mirror to adjusting arm and remove mirror.
- (2) Remove bolt, nut and flat washer which secure adjusting arm to mounting bracket and remove adjusting arm.
- (3) Remove four screws which secure mounting bracket to door panel and remove bracket.

d. Windshield Wiper Blades. Lift wiper blade and arm from windshield and disconnect wiper blade from arm.

e. Windshield Wiper Blade Arm.

- (1) Remove windshield wiper blade as outlined in (d) above.
- (2) Pull arm away from windshield and pull arm socket from output gear shaft.

f. Windshield Wiper Motors and Vacuum Switch.

- (1) Disconnect vacuum hose from windshield wiper motor and vacuum switch.
- (2) Remove two screws and nuts which secure vacuum switch to windshield frame and remove switch.
- (3) Remove nut and lock washer which secure crank to windshield wiper motor shaft and disconnect crank from shaft.
- (4) Remove screws and lock washers which secure wiper motor to windshield inner panel.
- (5) Remove windshield wiper motor.

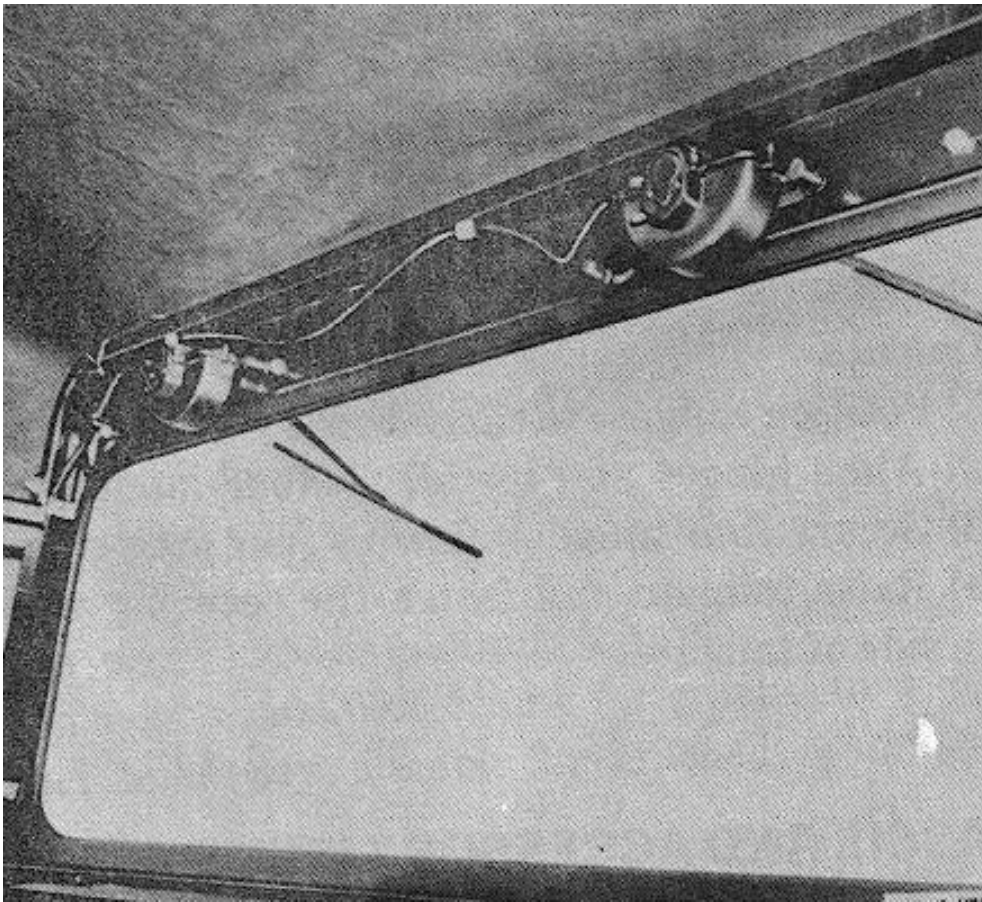

Figure 2-106. Vacuum windshield wipers.

g. Gasoline Can Mounting Bracket (Cargo).

- (1) Loosen gasoline can attaching web strap and remove gasoline can from mounting bracket.
- (2) Remove four nuts, lock washers and bolts which secure gas can mounting tray to cargo box and remove mounting tray.

h. Reflectors.

- (1) Remove two screws which secure each reflector to cargo box and/or front end sheet metal.
- (2) Pry reflector from cargo box and/or front end sheet metal panels.

i. Rifle Bracket. Remove two screws and lock washers which secure upper rifle bracket to cab panel and remove bracket.

j. Cargo Compartment Troop Seats (Side Mounted).

- (1) Remove cargo compartment cover and roof bows as outlined in (a) above.
- (2) Remove cotter pins and pins which attach seat back to cargo box front rail.
- (3) Lift troop seats and back rest straight up and remove from cargo box side panel channels.

2-124. Cleaning, Inspection and Repair.

- a. Inspect the cab soft top, cargo cover and end curtains for wear, damage or deterioration. Inspect all ropes for wear and damage.

- b. Inspect all mounting brackets for cracks, deterioration.
- c. Clean and lightly oil threads of all attaching bolts and nuts.
- d. Replace equipment that is unfit for further operation.

2-125. Installation.

a. Cargo Cover, End Curtains and Bows, (Fig 2-107)

- (1) Remove roof bows from storage and install ridge pole and bows in channels in seat back supports and cargo box.
- (2) Secure the three ridge pole sections to roof bows.
- (3) Install bolt, lock washer and nut through cargo box side channels and side bows.
- (4) Position cargo cover and front and rear end curtains over roof bows.
- (5) Roll sides down and tie ropes to cargo box front and side panel hooks.

b. Cab Soft Top. Refer to TM 9-2320-244-10 for canvas top installation and stowage procedures.

c. Rear View Mirrors and Brackets.

- (1) Position mirror mounting brackets on left and/or right door panels and secure with four screws. Tighten securely.
- (2) Position adjusting arm in bracket and install bolt, flat washer and nut.
- (3) Position mirror on adjusting arm and install flat washer and nut.
- (4) Adjust mirror for correct visibility and tighten mirror and adjusting arm nuts securely.

d. Windshield Wiper Blades. Install end of windshield wiper arm in slot of wiper blade.

e. Windshield Wiper Blade Arm.

- (1) Position windshield wiper blade arm socket on output gear shaft and push in.
- (2) Install wiper blade as outlined in (d) above.

f. Windshield Wiper Motor and Vacuum Switch.

- (1) Position wiper motor and vacuum switch on windshield inner panel and install attaching bolts and lock washers. Tighten securely.
- (2) Connect vacuum hose to windshield wiper motor and vacuum switch.

g. Gasoline Can Mounting Bracket.

- (1) Position gas can mounting tray to cargo box and secure with four bolts, lock washers and nuts. Tighten securely.
- (2) Position gasoline can in mounting tray and secure with web strap.

h. Reflectors.

- (1) Position reflectors to cargo box and/or front end sheet metal panels.
- (2) Install two screws which secure reflectors to cargo box and/or front end sheet metal.

(i). Rifle Brackets. Position brackets on cab panel and install two screws and lock washers. Tighten securely.

j. Cargo Compartment Troop Seats (Side Mounted).

- (1) Install troop seats and back rest in cargo box side panel channels.
- (2) Install pins which attach seat back to cargo box front end rails. Install cotter pins in seat back pins.
- (3) Install roof bows and cargo compartment cover as outlined in (a) above.

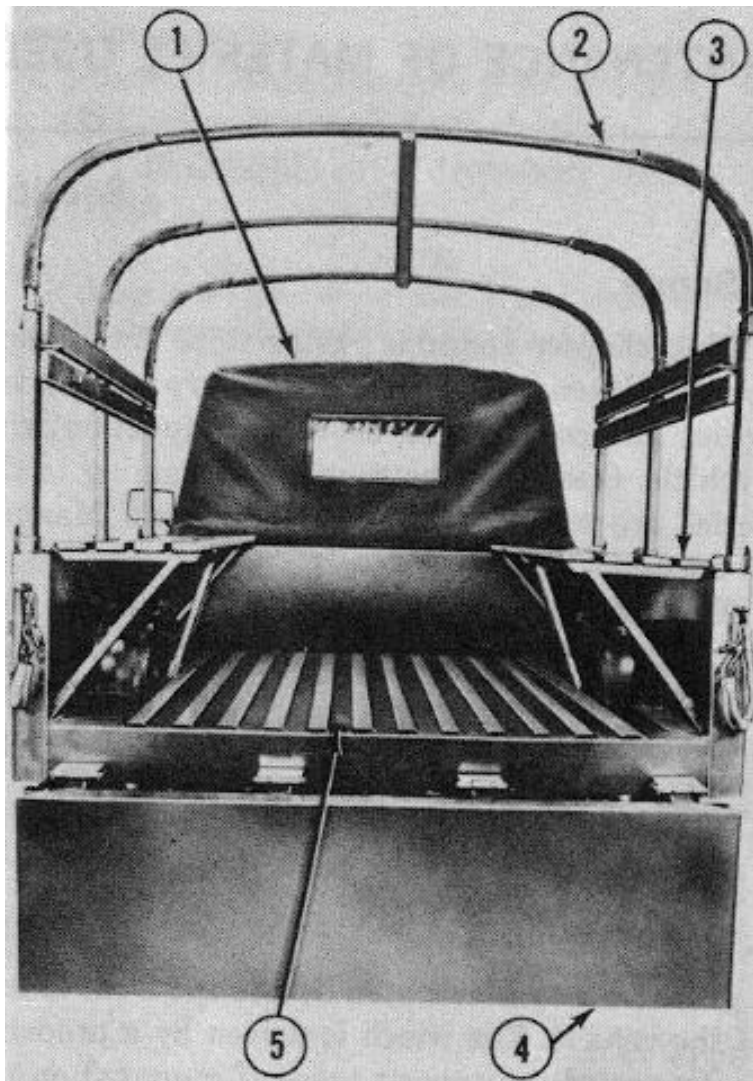

Figure 2-107. Cargo body area.

- 1 Cab top cover
- 2 Cargo box roof bow
- 3 Cargo personnel seat
- 4 Tailgate
- 5 Cargo box floor panel

CHAPTER 3

MAINTENANCE OF MATERIEL USED IN CONJUNCTION WITH THE VEHICLE

Section I. GENERAL

3-1. Scope.

- a. This chapter contains instructions for organizational maintenance of the special purpose kits, accessories and components used in conjunction with the vehicle. Operating instructions pertaining to the materiel are contained in the Operator s Manual, TM 9-2320-244-10.
- b. The various kits that make up the arctic and winterization kits for the cargo, ambulance and maintenance trucks are outlined below. Due to the complexity of installation and removal procedures, each kit is treated separately in this chapter.
- c. Refer to TM 9-2320-244-10 for description and replacement instructions for the fire extinguisher. Replace or recharge after use, or if loss of gas exceeds 1/2 pound. Refer to label on fire extinguisher for fully charged weight and for standard CO2 charge.

Section II. WINCH AND POWER TAKE-OFF

3-3. General.

A geared winch is mounted behind the front bumper of the vehicle. The winch is driven by a propeller shaft connected to a power take-off mounted on the transmission. The winch drum is provided with 150 feet of 7/16-inch cable terminated with a 4-foot chain and hook. The winch is engaged by a control handle on the end of the winch assembly. The power takeoff control, located inside of the vehicle cab, is used to select wind, neutral or unwind operations. The winch assembly contains a replaceable shearpin for overload protection. The shearpin is located at the winch input shaft.

3-4. Maintenance and Adjustment.

a. Lubrication Instructions. Refer to lubrication order, LO 9-2320-244-12 for periodic lubrication instructions.

b. Winch Drum.

- (1) At least once annually, completely unwind cable from winch drum.
- (2) Clean drum of all corrosion and spot paint where required.
- (3) Thoroughly lubricate drum bushings through lubrication fittings provided at each end of the drum.

c. Cable Cleaning.

- (1) Clean cable of all corrosion and dirt.
- (2) Rewind cable under load and apply CW-IIC lubricating oil to cable as it is winding on drum.
- (3) CW-IIC lubricating oil should be heated prior to application.
- (4) Place lubricant container in boiling water until it can be easily applied to the winch cable with a brush.
- (5) After each operation, and after fording operations, clean cable of dirt and rewind applying CWIIC lubricant to the cable as it is winding on drum.

d. Winch Safety Brake Adjustment.

- (1) Remove the cotter key from the drive shaft shearpin. Remove the set screw on the middle universal joint. Slide the hexshaft toward the rear far enough to clear the wormshaft.
- (2) Remove the outer jamnut from the brake band end. Insert a long punch through the shearpin hole in the wormshaft. Oscillate the shaft with the punch and at the same time tighten the inner jamnut on the brake band end until a noticeable drag is felt when the wormshaft is rotated in one direction. Hold the inner jamnut and install the outer jamnut. Tighten the outer nut to hold the adjustment.
- (3) Connect the drive shaft. Remove the punch from the shearpin hole in the wormshaft and position the universal joint front yoke on the worm shaft, aligning the shearpin holes. Install the shearpin and secure with cotter key.

3-5. Removal.

a. Driveshaft and Universal Joints. (Fig 3-1)

- (1) Remove cotter pin from shearpin.
- (2) Remove shearpin from winch driveshaft and winch input shaft.

(3) Loosen setscrew which secures driveshaft to winch input shaft and slide universal joint yoke slip joint rearward on driveshaft and disengage driveshaft from winch input shaft.

(4) Remove nut, lock washer and bolt which secures driveshaft to power take-off output shaft.

(5) Slide driveshaft forward and disengage from power take-off output shaft.

b. Shearpin (When Shearpin is Broken).

(1) Remove broken ends of shearpin from driveshaft yoke.

(2) Push universal joint yoke slip joint rearward on driveshaft and disengage universal joint from winch input shaft.

(3) Using a small drift, push shearpin out of winch input shaft.

c. Shearpin (When Shearpin is not Broken).

(1) Remove cotter pin from shearpin.

(2) Pull shearpin out of driveshaft yoke and winch input shaft.

NOTE

If shearpin is rusted or corroded, it may be necessary to drive shearpin out of yoke with a drift and hammer.

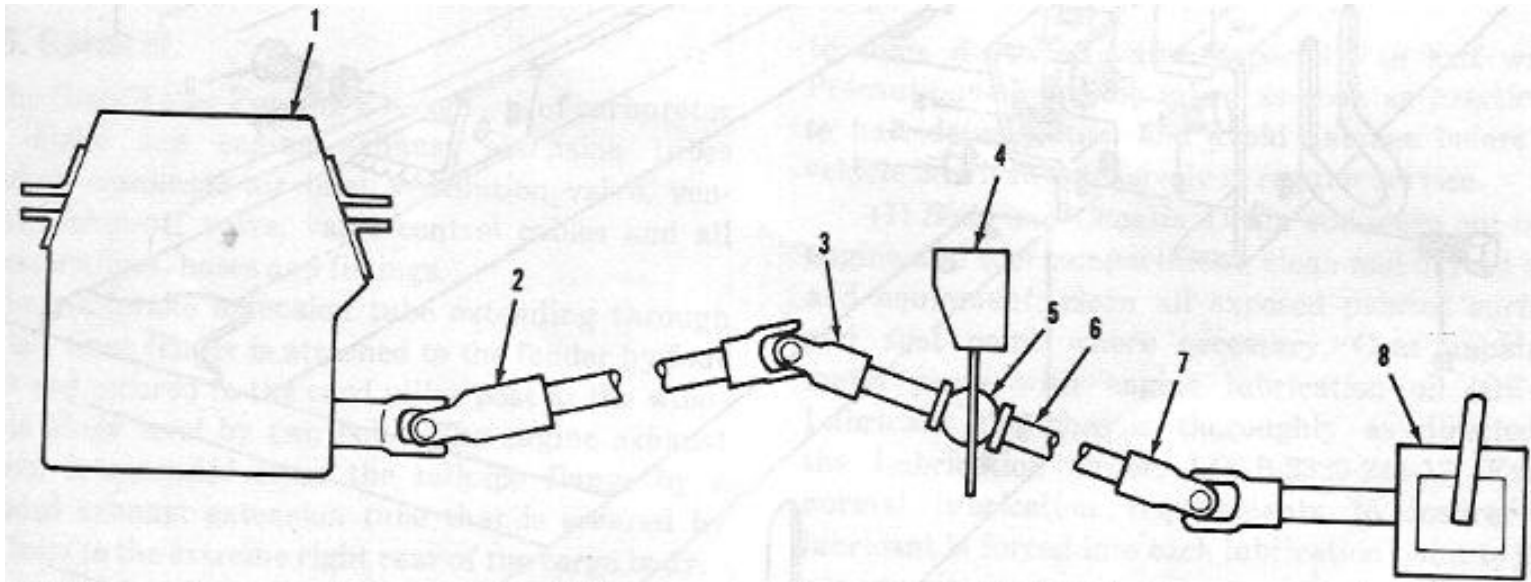

Figure 3-1 Winch driveshafts and joints.

1 Winch

2 Front joint assembly

3 Intermediate joint

4 Bracket and brace

5 Collar and bearing

6 Shaft

7 Rear joint

8 Power take-off

d. Winch Cable and Chain.

- (1) Place winch control in disengaged position and completely unwind cable from winch drum.
- (2) Loosen cable setscrew which secures cable to drum and remove cable.

e. Winch and Mounting Brackets. (Fig 3-2)

- (1) Remove winch driveshaft as described in (a) above.
- (2) Support winch assembly with a jack or other suitable lifting device.
- (3) Remove six bolts and lock washers which secure winch to rear mounting bracket.
- (4) Remove towing shackles; remove eight bolts, nuts and lock washers securing front bumpers to winch brackets. Remove eight bolts, nuts and lock washers securing bumper side rails to frame.
- (5) Lower jack and remove winch and front mounting brackets from vehicle.
- (6) Remove nuts, bolts and lock washers which secure front mounting brackets to winch assembly.
Remove front mounting brackets.
- (7) Remove nuts, bolts and lock washers which secure rear mounting bracket to frame assembly.
Remove rear mounting bracket.

3-6. Cleaning, Inspection and Repair.

WARNING

Drycleaning solvent and mineral spirits paint thinner are flammable and should not be used near an open flame. Use only in well ventilated areas to avoid prolonged breathing of fumes.

- a. Clean all parts with drycleaning solvent or mineral spirits paint thinner.
- b. Inspect winch cable for broken cable strands, rust, Corrosion and kinks.
- c. Inspect driveshaft for distortion, cracks, damaged splines.
- d. Inspect universal joints for wear, binding.
- e. Inspect slip joint to insure that it slides freely on splines.
- f. Inspect power take-off output shaft for corrosion, damage and burrs. Remove minor scratches or burrs with Crocus cloth.
- g. Inspect mounting brackets for cracks and elongated mounting bolt holes.
- h. Clean and lightly oil threads of all attaching bolts and nuts.
- i. Replace all parts that are unfit for further service.

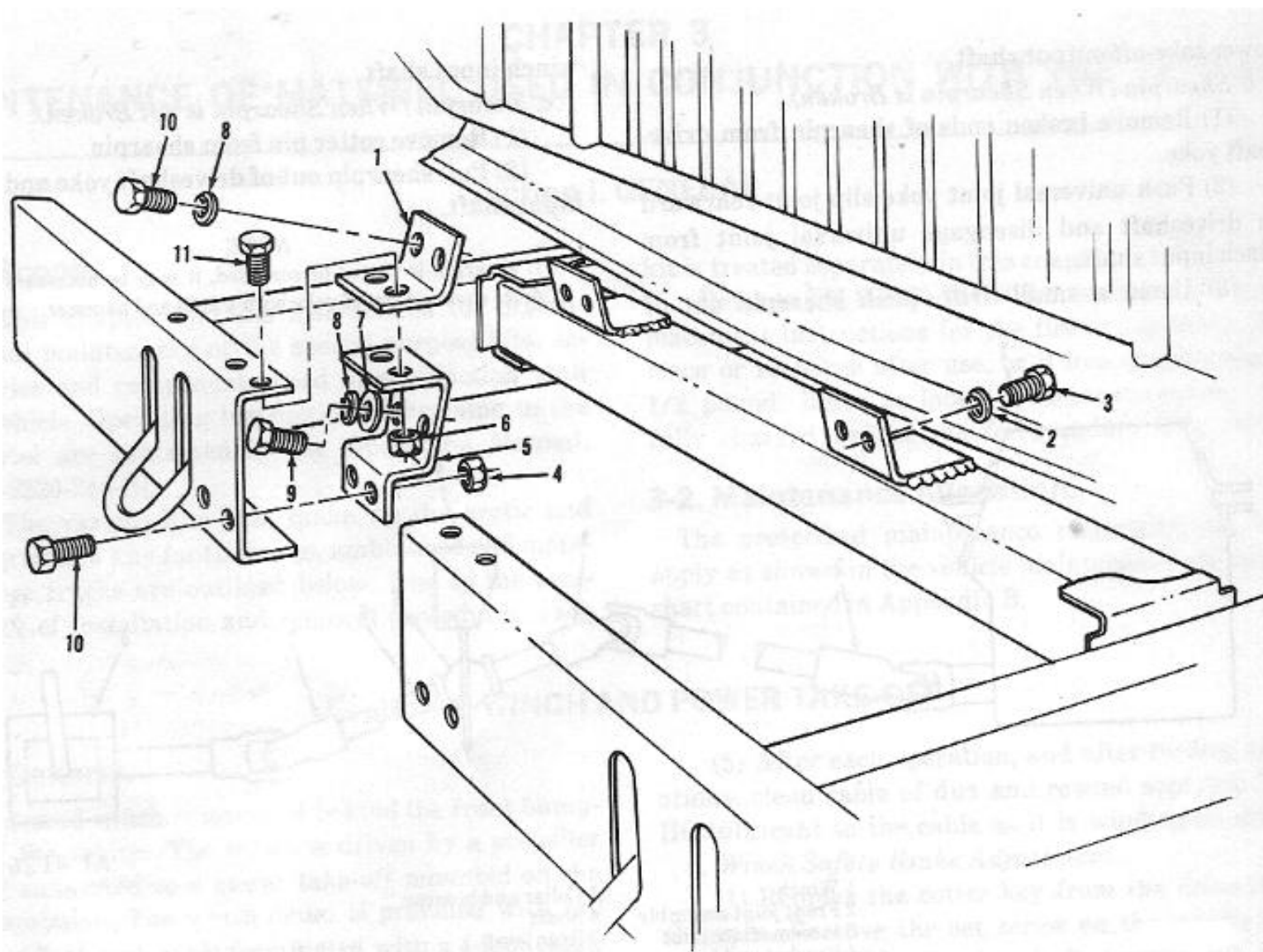

Figure 3-2. Winch mounting brackets.

1 Bracket	7 Washer
2 Lock washer	8 Lock washer
3 Bolt	9 Bolt
4 Nut	10 Bolt
5 Support	11 Bolt
6 Nut	

3-7. Installation.

a. Driveshaft and Universal Joints. (Fig 3-1)

- (1) Slide driveshaft on power take-off output shaft. Install bolts, lock washer and nut which secures driveshaft to power take-off output shaft. Tighten securely.
- (2) Position driveshaft to winch input shaft and slide slip joint yoke forward.
- (3) Line up holes and install shearpin through universal joint yoke and winch input shaft.
- (4) Install cotter pin in shearpin.

b. Shearpin.

- (1) Aline holes in winch input shaft and drive-shaft yoke.
- (2) Insert shearpin through universal joint yoke and power take-off output shaft.
- (3) Install cotter pin in shearpin.

c. Winch Cable and Chain.

- (1) Apply a thin film of engine oil to winch drum surface.
- (2) Insert cable through winch rollers and around the drum at the rear.
- (3) Insert cable through hole in drum and secure with setscrew.
- (4) Wind cable under load, applying CW-11C lubricant to the cable as it winds on drum. Refer to paragraph 3-4c for method of applying CW-11C lubricant.

d. Winch and Mounting Brackets. (Fig 3-2)

- (1) Position rear mounting bracket to frame assembly; install bolts, nuts and lock washers and tighten.
- (2) Install front brackets, bolts and lock washers into winch worm gear housing outer bolt holes, and tighten.
- (3) Support winch on jack or other suitable lifting device and raise into position.
- (4) Install six bolts and lock washers and secure rear bracket and winch assembly. Tighten bolts securely.
- (5) Install eight bolts, lock washers and nuts through front brackets and front bumpers. Tighten all eight attaching bolts. Install bolts, nuts and lock washers securing side rail extensions to frame. Tighten bolts securely.
- (6) Remove jack or lifting device.
- (7) Connect winch driveshaft as described in (a) above.

33.11. DEEP WATER FORDING KIT

33-B2. DESCRIPTION

The Deep Water Fording Kit (Fig. 33-B1) consists of carburetor air intake and engine exhaust extension tubes (stacks), crankcase air inlet ventilation valve, ventilation shut-off valve, valve control cables and all necessary lines, hoses, and fittings.

The air intake extension tube extending through the left front fender is attached to the fender by four bolts and secured to the cowl pillar post at the windshield hinge level by two bolts. The engine exhaust system is extended from the tail pipe flange by a shielded exhaust extension tube that is secured by two bolts to the extreme right rear of the cargo body.

A control handle mounted to the left of the steering column on the instrument panel opens and closes the engine fording valves. One ventilation fording valve is mounted in the crankcase air vent hose. This hose connects the crankcase and carburetor air cleaner. The other ventilation fording shut-off valve is attached to the hose inlet fitting of the engine intake manifold.

The bellhousing of the engine is pressurized by a line which connects in the engine crankcase lower ventilating hose.

Note: BEFORE FORDING: Remove the envelope containing the drain plug from the glove box and install the drain plug in the belihousing drain hole. AFTER FORDING: Reverse the above procedure.

Ventilation of the front and rear axle housings, transmission, transfer case, master cylinder and fuel tank is accomplished by hoses, lines and fittings

extending to the carburetor air cleaner. These lines must be checked before all fording operations. Make sure all connections are tight and that the lines and hoses are not damaged or broken.

The insulating compound furnished is applied at time of kit installation to the electrical lead connections on the starter, starter switch and batteries (with the exception of ground connections). Additional insulation may be applied prior to fording, if deemed necessary.

With the kit properly installed, the vehicle can ford hard bottom water crossings up to a depth of 60 inches.

Caution: When fording water in depths over 42 inches, the engine fan belts must be loosened to allow slippage of the engine fan.

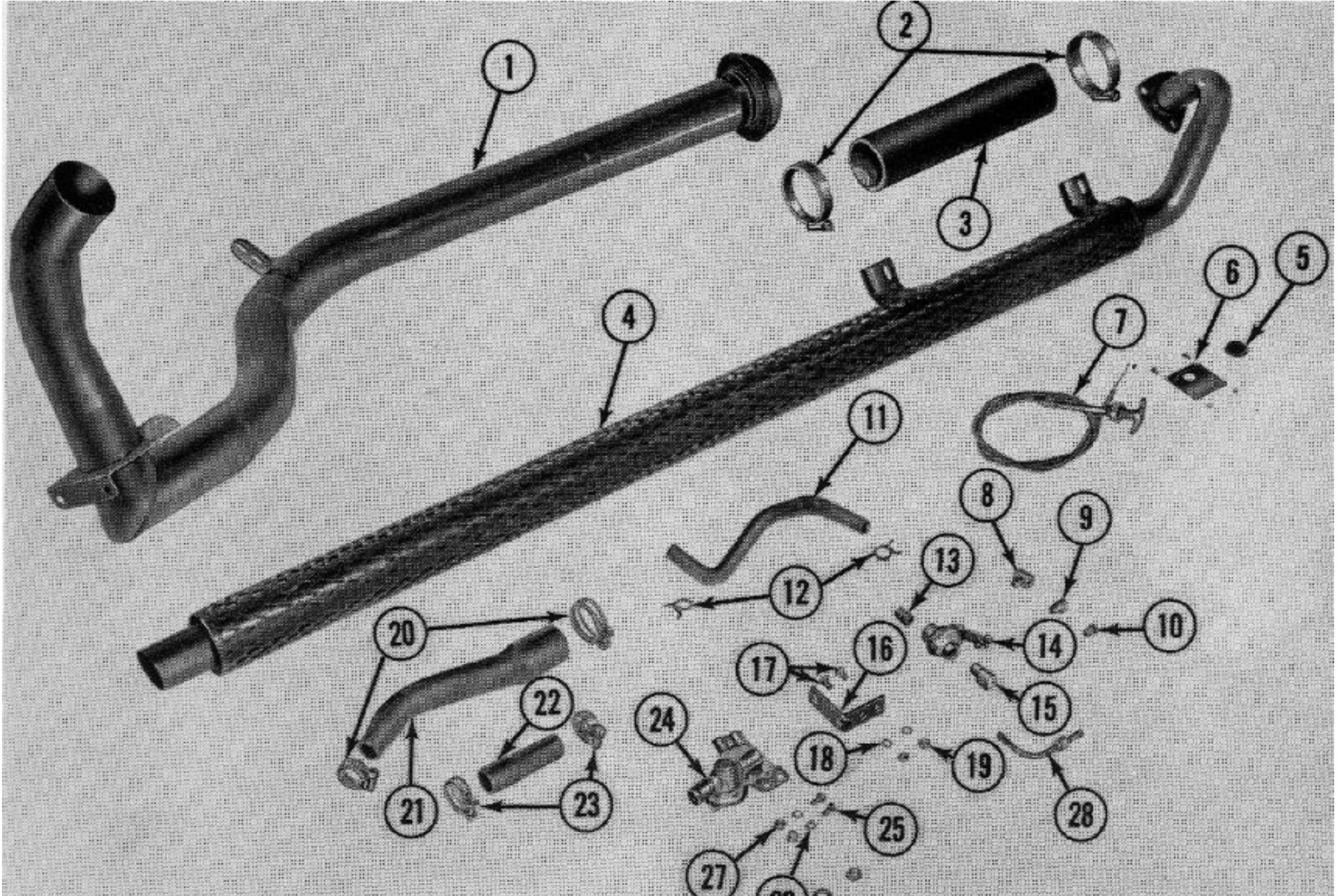

FIG. 33-B 1 DEEP WATER FORDING KIT

1 Air Intake Extension Tube	8 Fitting	15 Elbow	22 Crankcase Upper Vent Hose
2 Clamps	9 Fitting	16 Support Bracket	23 Clamp
3 Flexible Air Tube	10 Adapter	17 Bolt	24 Fording Ventilation Valve
4 Exhaust Extension Tube	11 Oil Filler Vent Hose	18 Lock Washer	25 Bolt
5 Rubber Grommet	12 Clamps	19 Nut	26 Lock Washer
6 Instruction Plate	13 Adapter	20 Clamp	27 Nut
7 Dual Cable Control	14 Fording Shut Off Valve	21 Crankcase Lower Vent Hose	28 90 degree Tube

33-B3. MODIFICATION AND INSTALLATION PROCEDURE

The left front fender, cowl firewall, windshield support pillar, instrument panel and the right rear support of the M7 15 vehicle body must be modified in order to properly install the Deep Water Fording Kit. A template is supplied with the kit for marking the three inch hole to be cut in the left front fender for the mounting of the air inlet extension tube. The air inlet extension tube mounting plate is used to mark the plate attaching holes in the fender. The fording control valve instruction plate is used to mark the holes to be drilled, in the instrument panel, for securing the instruction plate and fording ventilation valves control handle. All modifications of the vehicle are explained in the installation procedures which follow.

33-B-4. Discarded Parts

Discarded parts will be disposed of in accordance with AR-755-6 or AR-755-10.

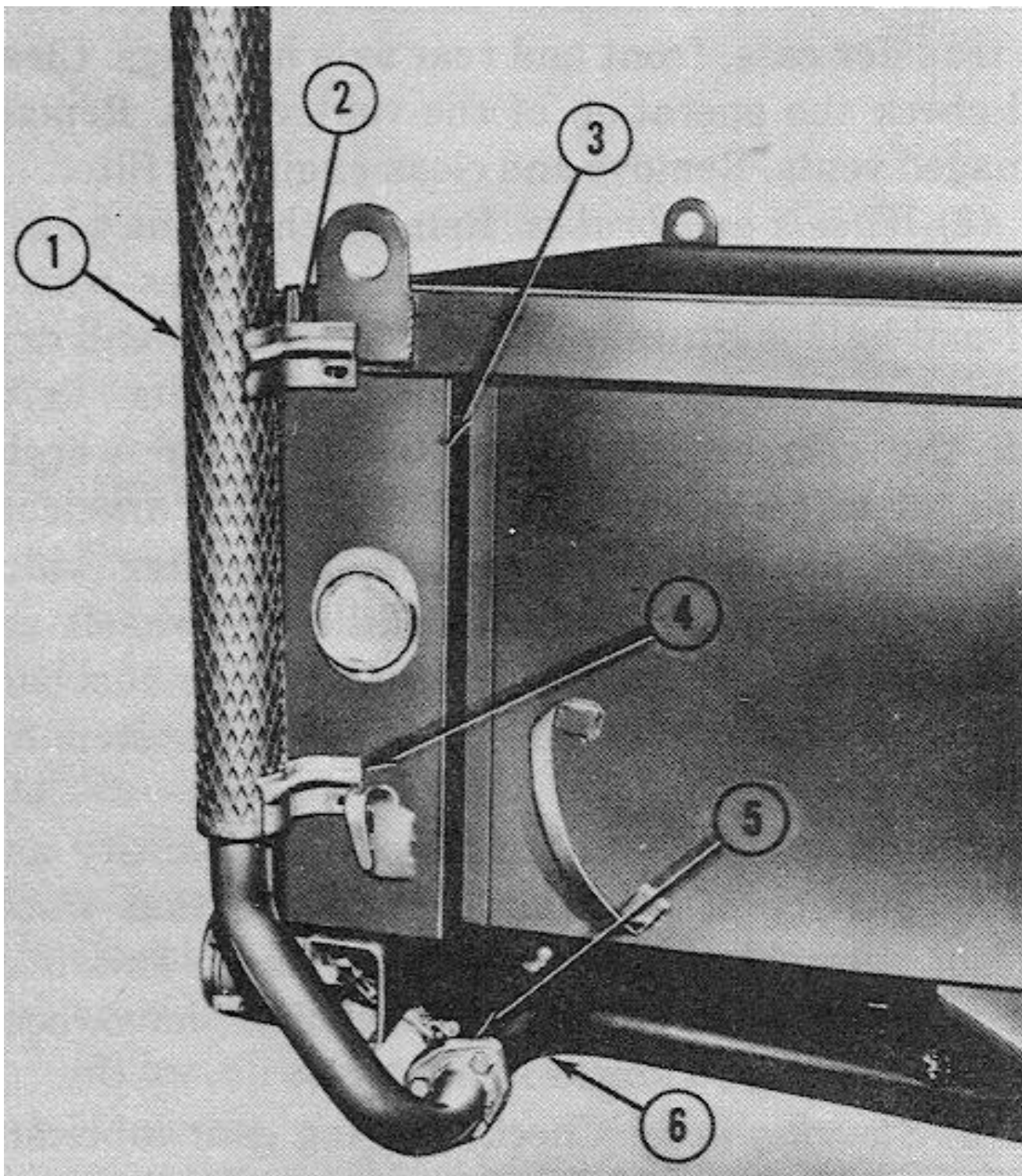

FIG. 33-B2 EXHAUST EXTENSION TUBE

- 1 Shielded Exhaust Extension Tube
- 2 Extension Tube Upper Support Bracket
- 3 Vehicle Rear Body Support
- 4 Extension Tube Lower Support Bracket
- 5 Flange Gasket
- 6 Vehicle Engine Exhaust Pipe

33-B5. Exhaust Extension Tube

Mount the shielded exhaust extension tube using a gasket between the tail pipe flange and the tube flange. Use three (3) 7/16-20x1½ bolts and hug-lock nuts to secure the extension tube to the exhaust pipe flange. On M715 Cargo Trucks, holding the tube vertically and in line with the rear support of the body, use a center punch and mark centers of the two support bracket holes (Fig. 33-B2). Drill two (2) 1 3/32" holes in the body support and use two (2) 3/8-24x1 1/8 bolts, lock-nuts and washers to secure the tube brackets to the body. On the Ambulance Vehicle (M725), mounting holes to hold the tube in the vertical position are provided on the vehicle body. Remove screws plugging holes. Use two (2) 3/8-24x1 bolts, lock washers and plain washers to secure the tube brackets to the body.

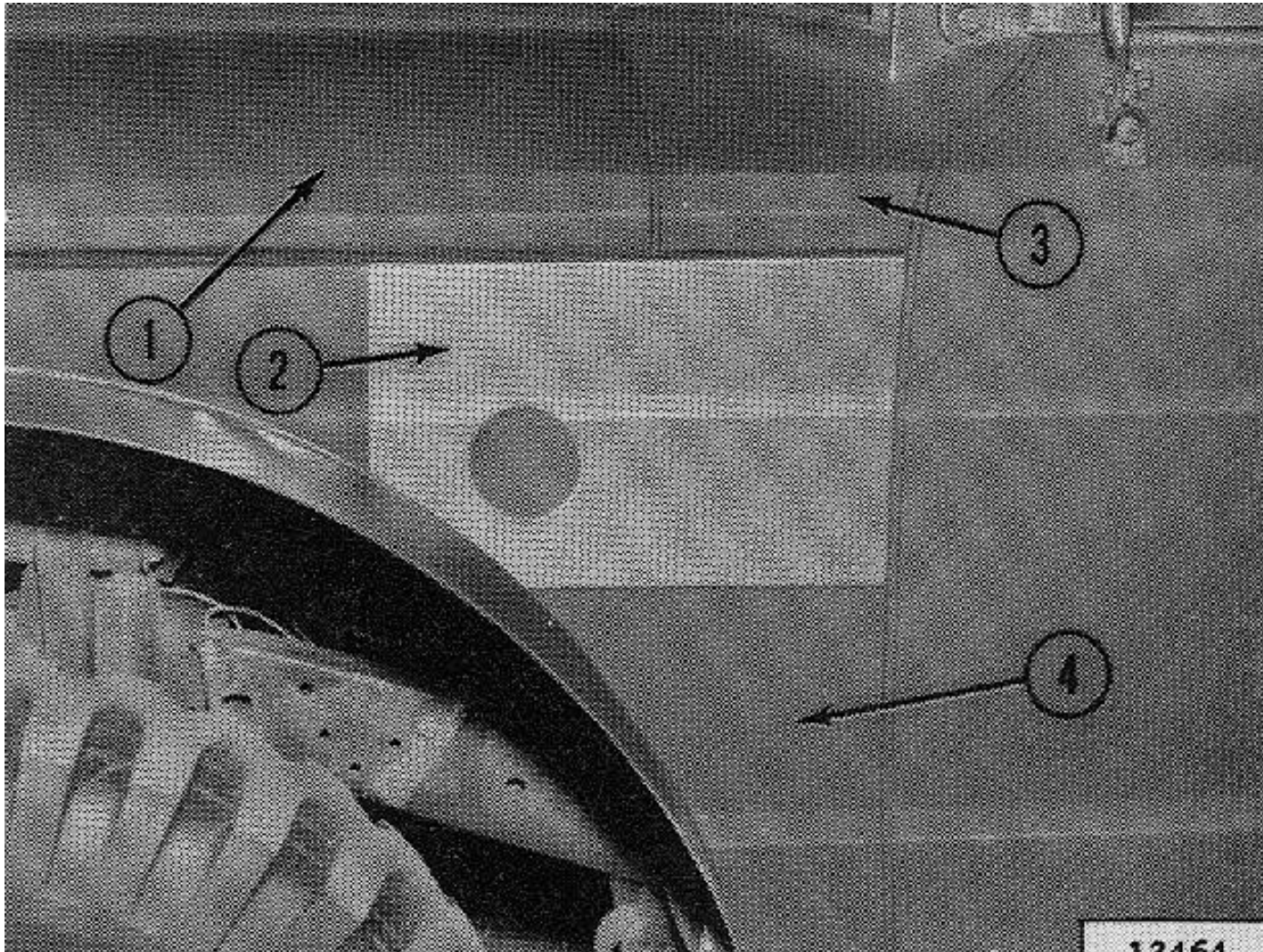

FIG. 33-B3 TEMPLATE POSITIONED ON FENDER

- 1 Hood
- 2 Marking Template
- 3 Cowl
- 4 Left Front Fender

33-B6. Air Intake Extension Tube

Place the kit supplied template on left front fender panel and use the center punch to mark center position of the 3 hole (Fig. 33-B3). Remove template and cut the 3 dia. hole for the extension tube. Then in horizontal alignment with the 3 dia. hole, mark the first two upright support flanges of the cowl firewall. Cut out the marked segments of both support flanges (Fig. 33-B4).

Note: Two upright support flanges of the cowl firewall must be cut as shown in Fig. 33-B4 to allow clearance for the air inlet extension tube when installed.

Position the flexible air tube in the sawed fender hole. Then, using the mounting bracket as a template, mark centers of the two upper and two lower 11/32" dia. mounting holes on the fender. Drill holes and install four (4) 5/16-24x7/8" bolts, nuts and lock washers to secure the extension tube bracket to the fender (Fig. 33-B5).

Position the short angle bracket (taken from the kit) on the welded bracket of the air tube and after aligning it with the cowl secure it to the bracket with two (2) 5/16-24x7/8 bolts, nuts and lock washers.

Using the center punch, mark the center of the angle bracket hole. Drill a 11/32" dia. hole in cowl pillar post and secure the angle bracket to the cowl with one 5/16-24x3/4 bolt, nut and lock washer (Fig. 33-B7).

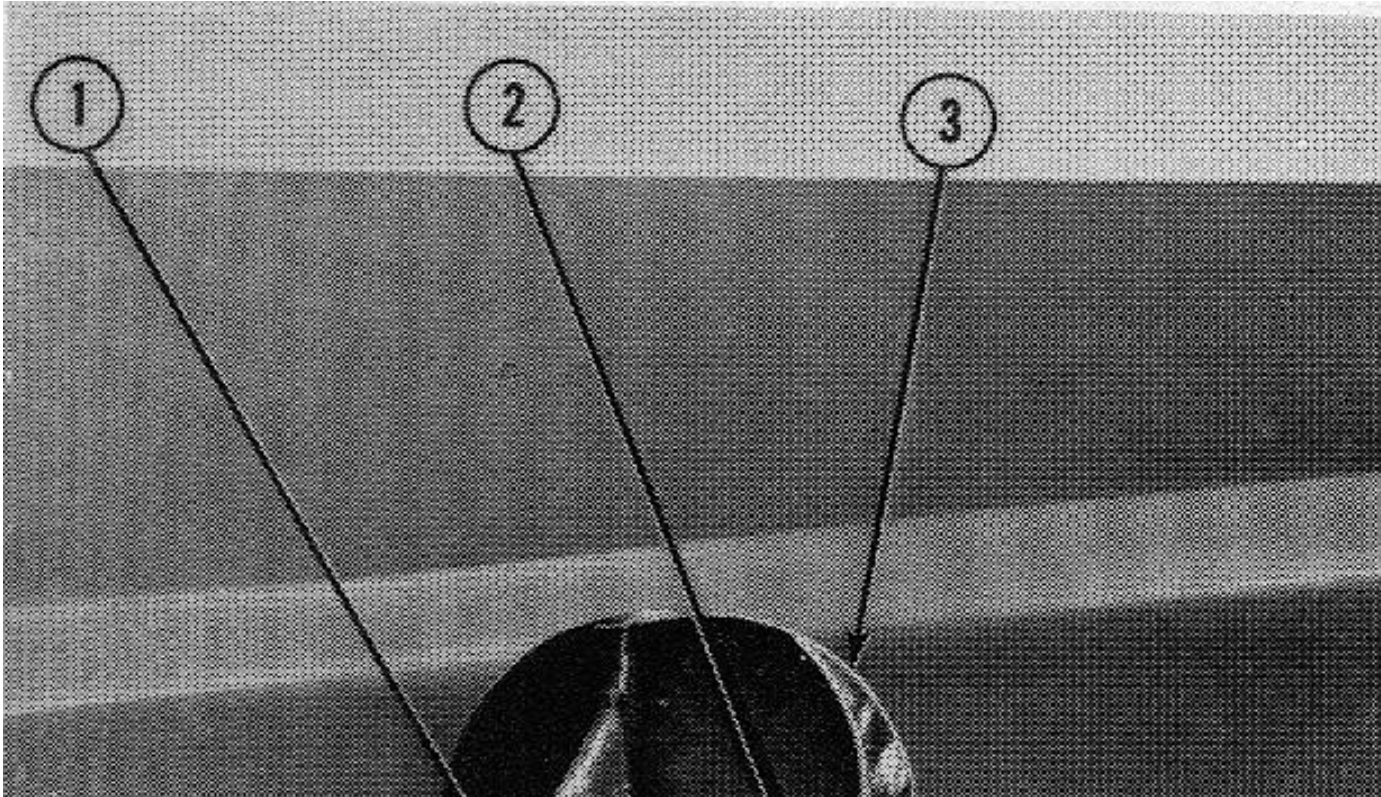

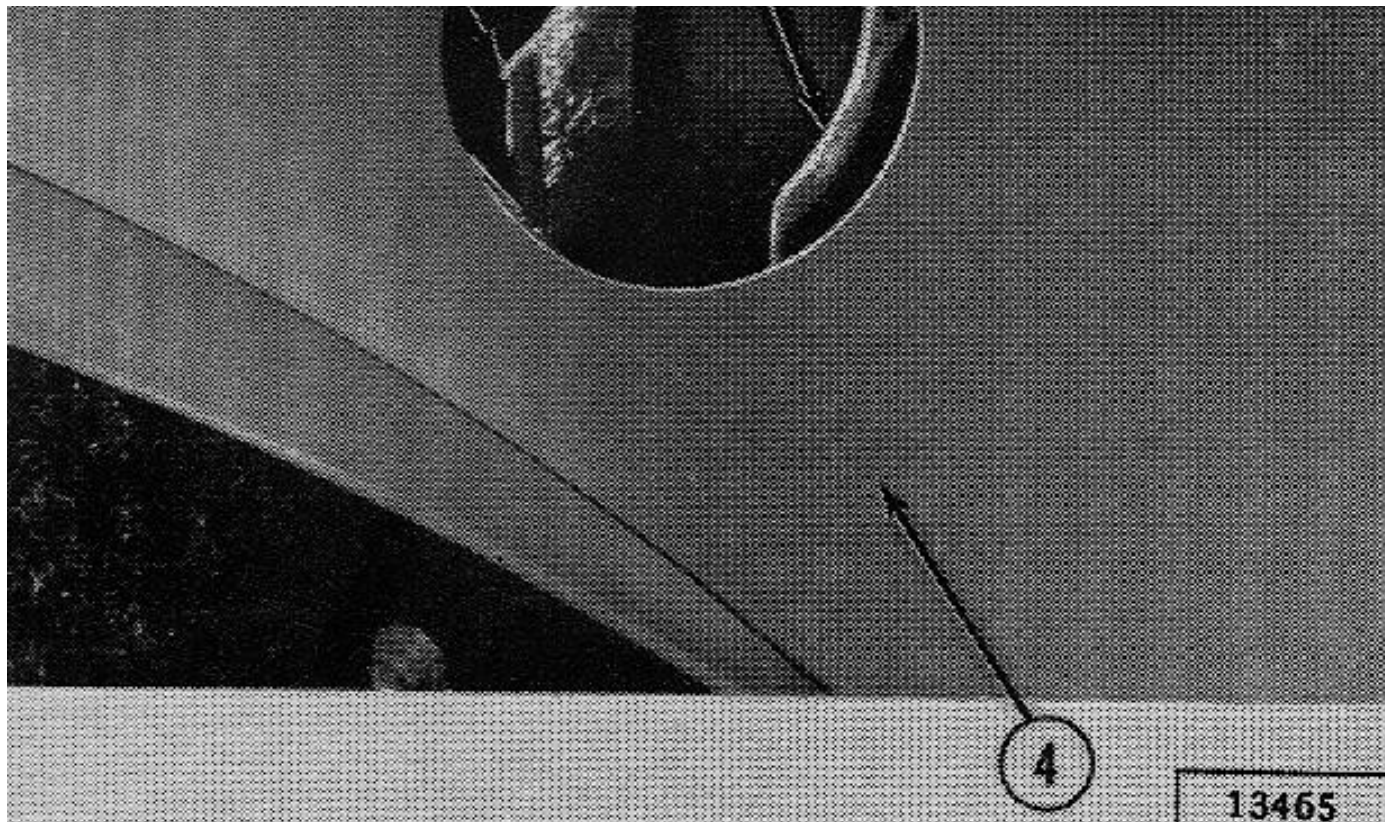
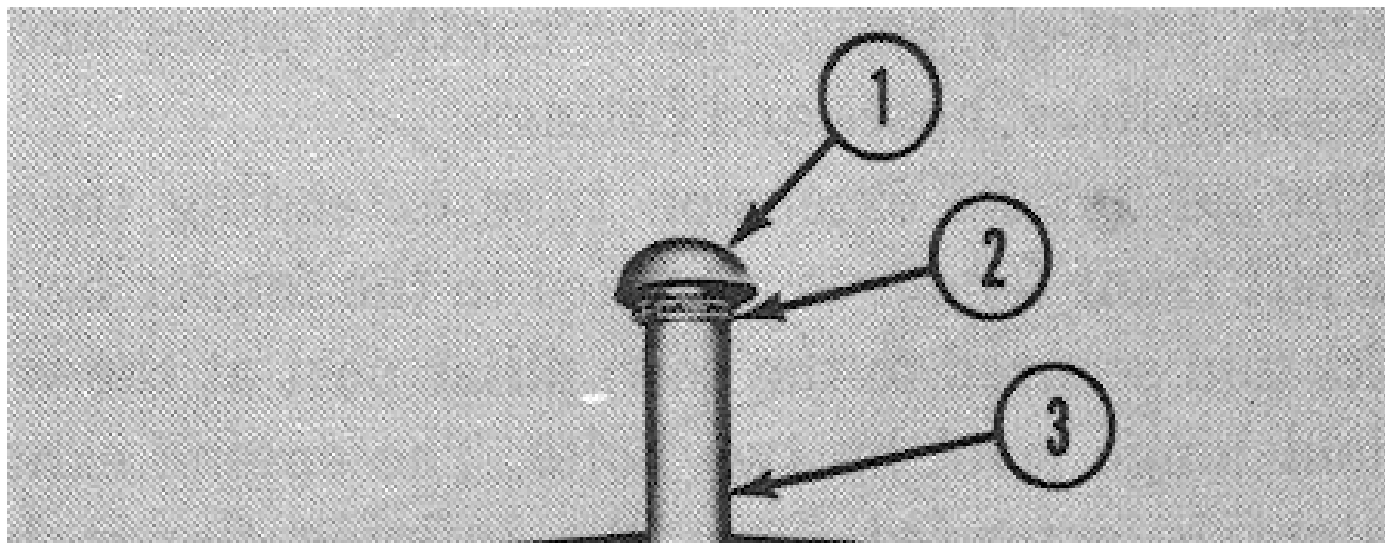

FIG. 33-B4 CUTS IN FIREWALL FLANGES

- 1 Inner Firewall Flange
- 2 Outer Firewall Flange
- 3 3 Inch Diameter Hole
- 4 Left Fender



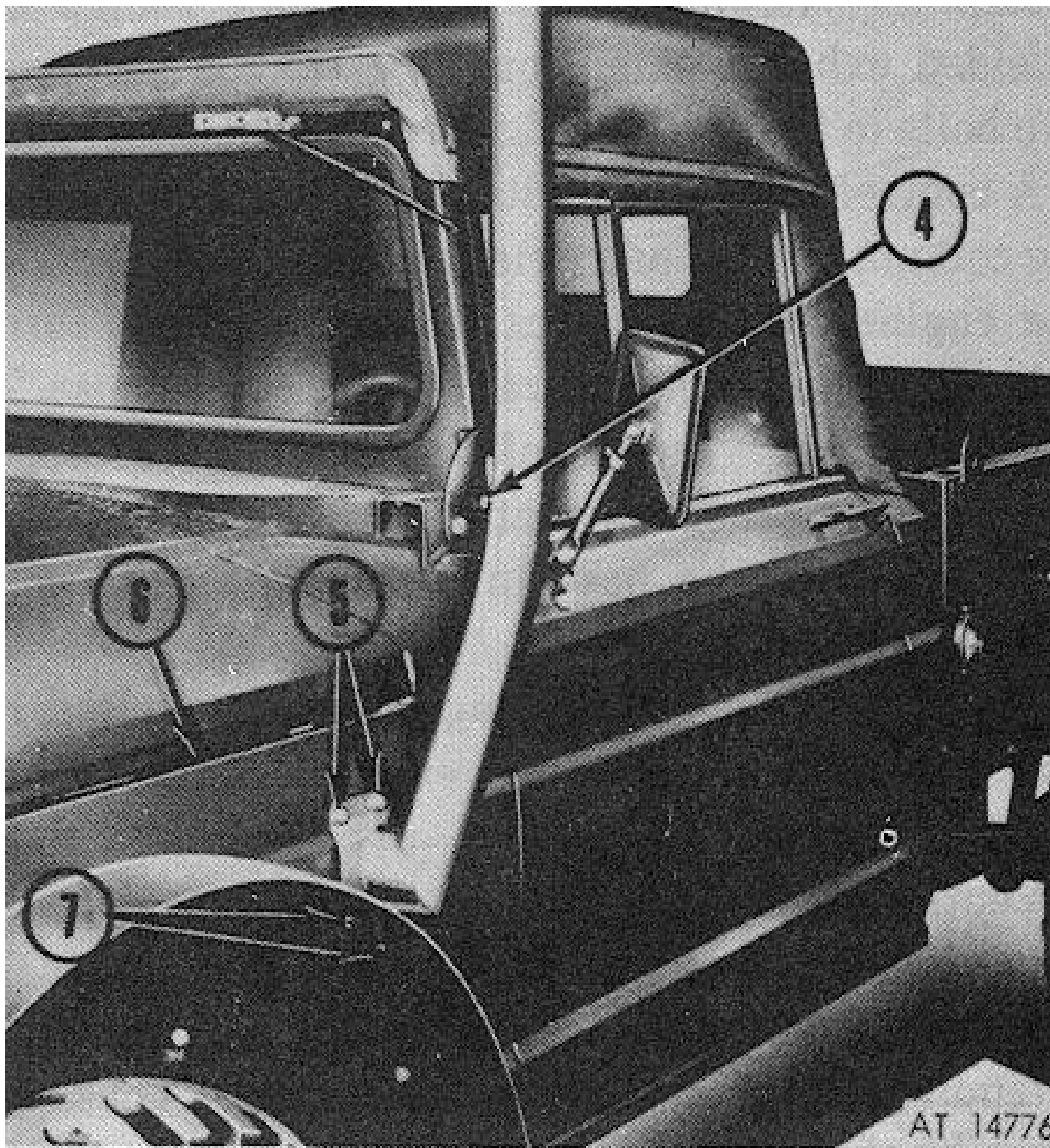
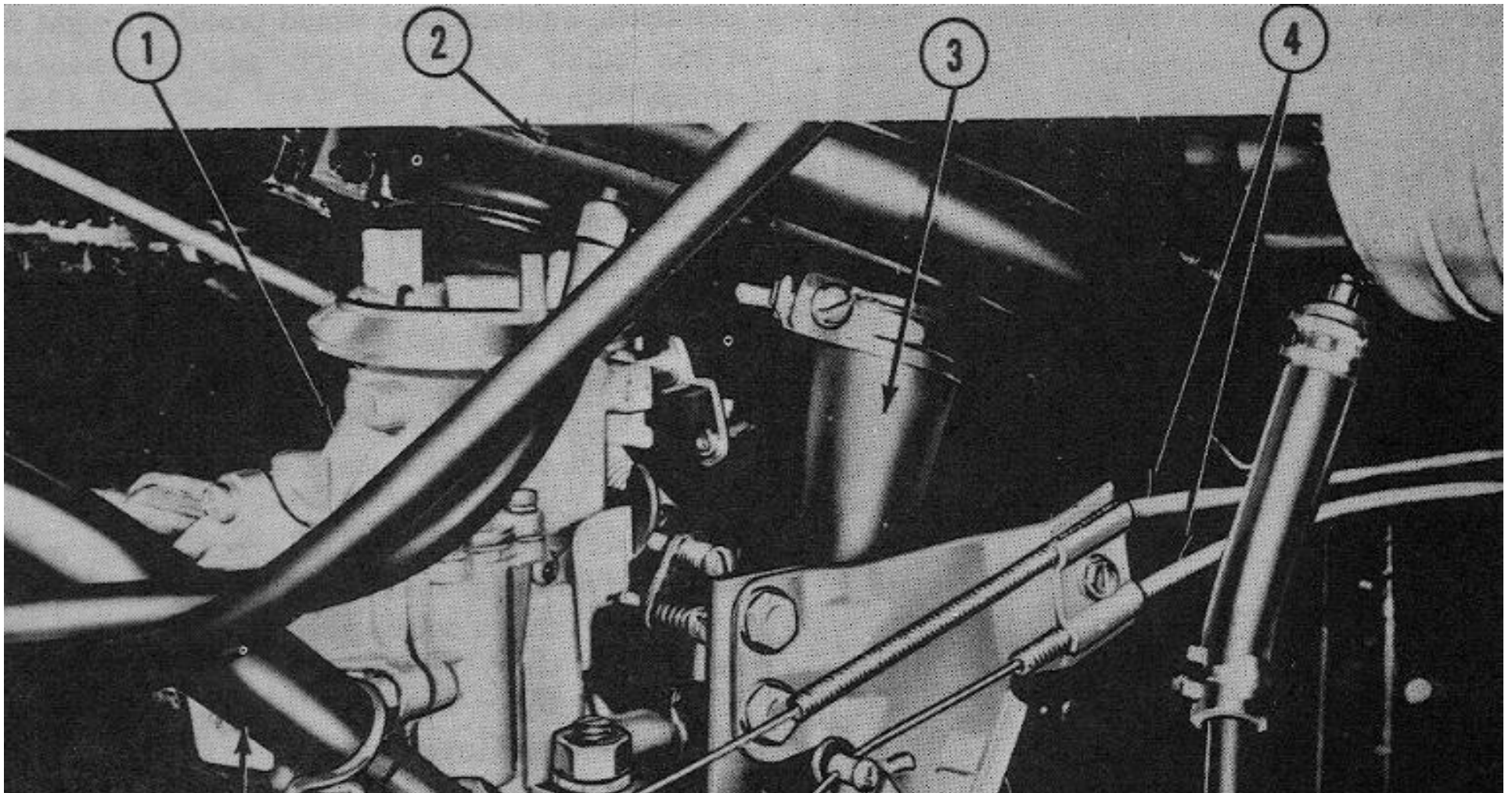

FIG. 33-B5 AIR INTAKE EXTENSION TUBE

- 1 Rain Deflector and Precleaner
- 2 3 Inch Diameter Clamp
- 3 Air Intake Extension Tube
- 4 Extension Tube Top Support Bracket
- 5 Upper Mounting Bolts
- 6 Left Front Fender
- 7 Lower Mounting Bolts

33-B7. Crankcase Air Ventilation Valve Refer to Fig. 33-B6.

Loosen the air cleaner mounting clamp screw and raise air cleaner off carburetor and slightly to one side. Loosen the clamps securing the crankcase ventilation hose to the crankcase and air cleaner. Remove and discard this vent hose. Position the new lower vent hose with bellhousing hose adapter installed on the crankcase and tighten in position with a hose clamp. Secure the fording ventilation valve on the vent hose. Remove the rear carburetor mounting nut and lock washer and place the ventilation valve support bracket on this mounting stud and secure with lock washer and nut. Align the ventilation valve to the bracket and secure with two (2) 1/4-28x1/2 bolts, nuts and lock washers.



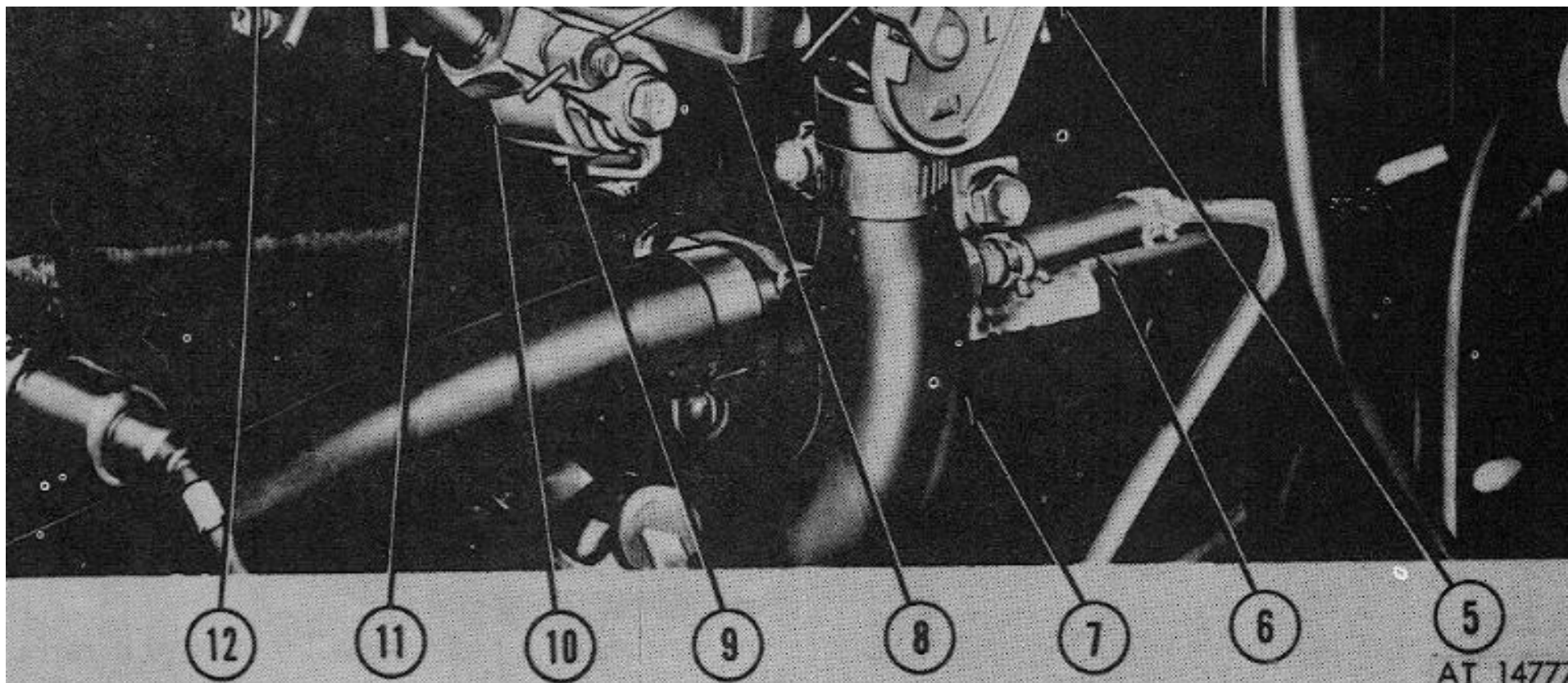

FIG. 33-B6 FORDING VALVES

1 Carburetor	5 Fording ventilation Valve	9 Fording Cutoff Valve
2 Air Cleaner	6 Bellhousing Pressure Line	10 Adapter
3 Crankcase Top Vent Hose	7 Crankcase Lower Vent Hose	11 Engine Ventilation Valve
4 Valve Control Cables	8 Valve Support Bracket	12 Oil Filler Vent Hose

33-B8. Fording Shut-Off Valve

Refer to Fig. 33-B6.

Disconnect the engine ventilation hose from the oil

filler tube and engine ventilation valve at the base of the carburetor on the intake manifold. Remove and discard this hose. Remove the engine ventilation valve from the intake manifold fitting. Install the nipple and fording shut-off valve on the intake manifold fittings.

Note: When installing the fording shut-off valve, the valve control arm must be in alignment with the fording valve mounting bracket on the carburetor.

Install the engine ventilation valve to the fording shut-off valve. Position ventilation valve hose on oil filler tube and engine ventilation valve and secure with two clamps.

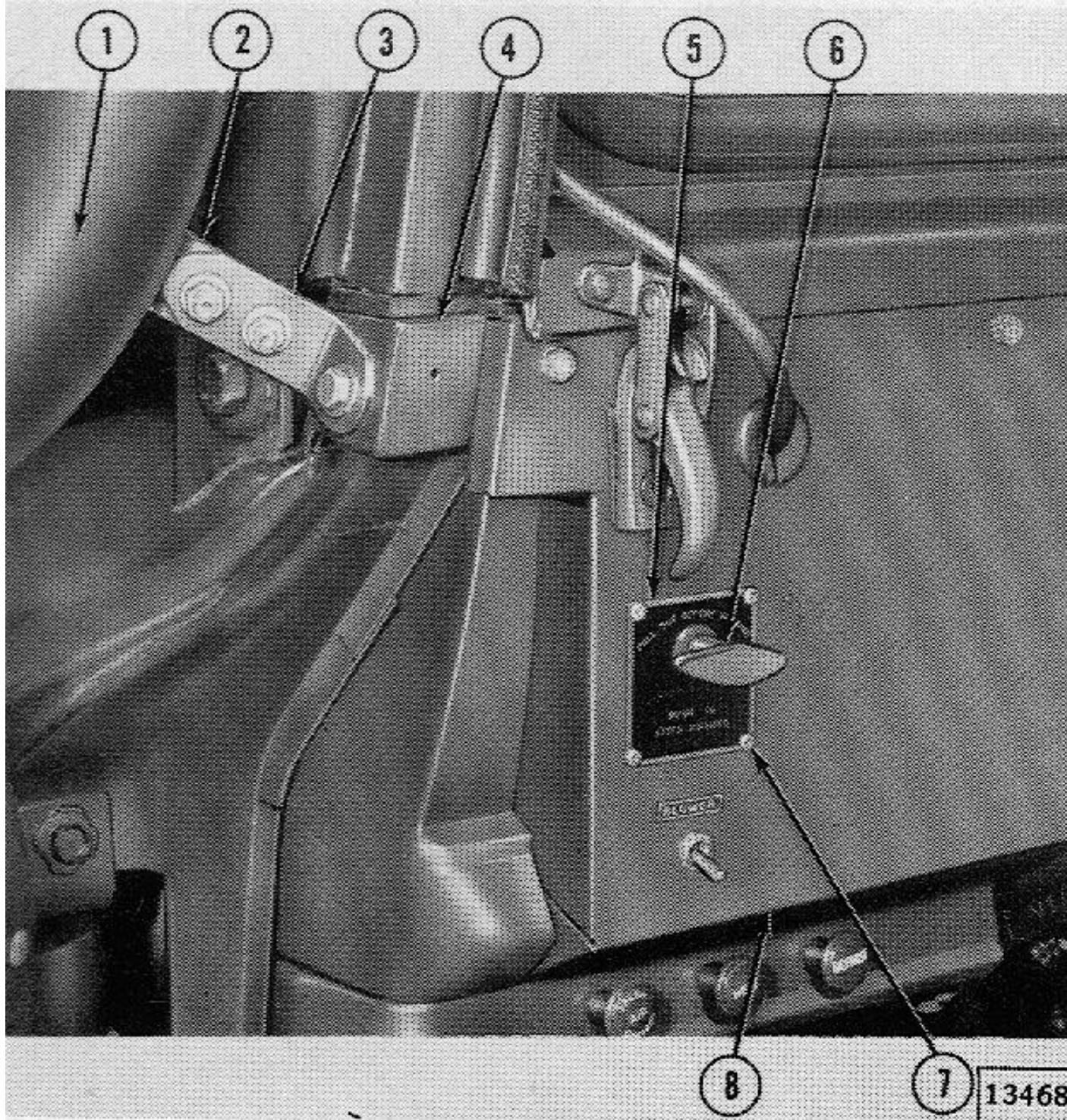

FIG. 33-B7 FORDING VALVES CONTROL KNOB AND INSTRUCTION PLATE

- 1 Air Intake Extension Tube
- 2 Extension Tube Top Support Bracket
- 3 Angle Attaching Bracket
- 4 Cowl Pillar Post
- 5 Instruction Plate
- 6 Control Knob
- 7 Self Threading Screw
- 8 Instrument Panel

33-B9. Valve Control Cables and Dual Valve Control

Using the instruction plate as a template, place it on the instrument panel in location shown in Fig. 33-B7. Locate the center of the large hole 2 in from the left edge of the instrument panel and 4 3/8" up from the lower edge. Center mark the five holes to be drilled. Remove plate and drill four .116 dia. (No. 32 drill) and one 11/16" dia. holes. Then position plate on instrument panel and secure with four (4) 6-18x3/8 self tapping screws.

Position rubber cable grommet in the existing hole of firewall. Insert dual cables through the instrument panel and install cable control washer and nut over cables. Insert cables through grommet in firewall. Position cable control in instrument panel and secure with washer and nut. Position cable conduits in cable clamp of fording ventilation valve bracket and secure with screw. Position cable wires in valve arms as shown in Fig. 33-B6 making sure cable control knob is all the way in and the arm levers are all the way forward. Tighten arm screw to secure the cable wires.

33-B10. Crankcase Upper Ventilation Hose

Position crankcase upper ventilation hose to fording ventilation valve and secure with clamp. Position air cleaner on carburetor and upper ventilation hose. Tighten the clamps to secure the air cleaner and upper ventilation hose.

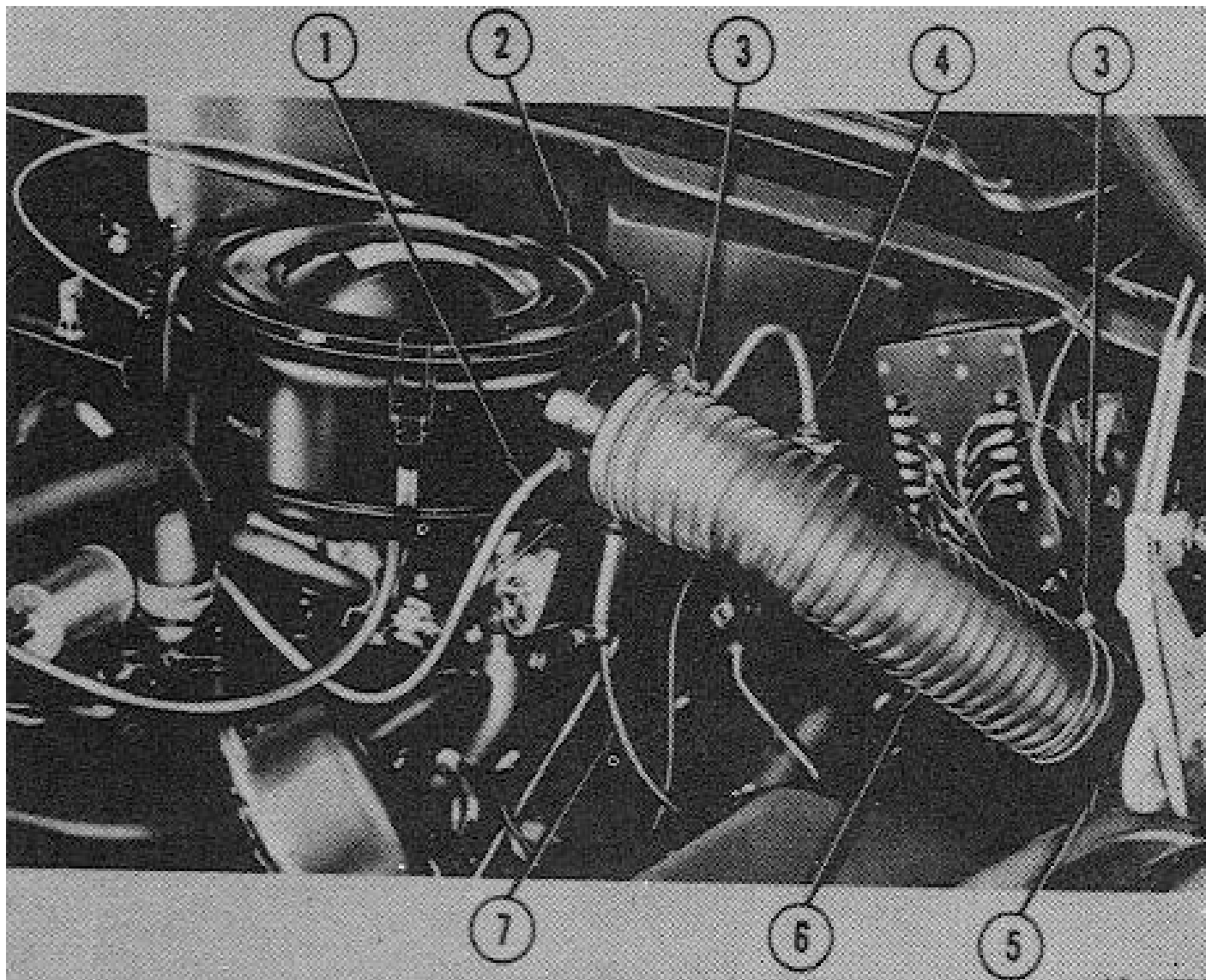

FIG. 33-B8-AIR CLEANER FLEXIBLE AIR TUBE

- 1 Fuel Pump Breather Hose
- 2 Carburetor Air Cleaner
- 3 Clamp
- 4 Master Cylinder Breather Hose
- 5 Air Intake Extension Tube
- 6 Air Cleaner Flexible Air Tube
- 7 Power Train Breather Hose

33-B11. Air Cleaner Flexible Air Tube Position the flexible air tube on the air inlet tube and engine air cleaner. Secure tube with two 3 1/8 clamps (Fig. 33-B8).

33-B12. REMOVAL OF DEEP WATER FORDING KIT

33-B13. Exhaust Extension Tube

- a. Remove the three cap screws and huglock nuts securing the tube to the exhaust pipe flange. Remove and discard gasket.
- b. Remove two cap screws, lock nuts and washers that secure the tube brackets to the body support. Remove extension tube.

33-B14. Air Inlet Tube

- a. Disconnect the carburetor air cleaner flexible tube from the air inlet tube.
- b. Remove two cap screws, nuts and lock washers securing the air tube to the crown of the left front fender.
- c. Remove two cap screws, nuts and lock washers securing the air tube to the left front fender apron.
- d. Remove the cap screw, nut and lock washer securing air tube bracket to the cowl pillar post. Slip air tube from hole in fender apron and remove air tube from vehicle.

33-B15. Air Cleaner Flexible Tube

Loosen clamp securing flexible air inlet tube to carburetor air cleaner and remove air tube.

33-B16. Valve Control Cables and Dual Valve Control

- a. Loosen the air cleaner mounting clamp screw and raise air cleaner off carburetor and slightly position to one side.
- b. Loosen screws securing the cable wires to the fording shut-off valve arm and the ventilation valve in the crankcase vent hose.
- c. Loosen screw securing the two cable housings to the ventilation valve bracket. Remove cables from bracket.
- d. Remove nut and washer securing dual cable control to instrument panel. Pull control and cable from instrument panel and remove. Place nut and washer on dual control.
- e. Remove screws securing instruction plate to instrument panel and remove plate.

33-B17. Crankcase Air Ventilation Valve

- a. Loosen the vent hose clamp at the air cleaner base and place air cleaner to one side. Loosen the vent hose clamp at the ventilation fording valve and remove upper vent hose.
- b. Remove nut and lock washer securing fording ventilation valve to carburetor mounting stud. Remove bracket from stud and replace nut and lock washer.
- c. Loosen clamp securing lower vent hose to fording ventilation valve and remove ventilation valve.
- d. Remove bellhousing vent tube connecting hose from nipple fitting of lower crankcase vent hose,
- e. Loosen clamp securing lower vent hose to engine crankcase and remove vent hose,
- f. Using a new engine crankcase ventilation hose having a bellhousing nipple fitting installed, place hose on crankcase and secure in position with screw clamp.
- g. Connect bellhousing tube connecting hose to vent hose nipple and secure with squeeze clamp.

33-B18. Fording Shut-off Valve

- a. Disconnect the engine ventilation hose from the oil filler tube and the engine ventilation valve mounted on the fording shut-off valve. Remove hose.
- b. Remove engine ventilation valve from the fording shut-off valve.
- c. Remove fording shut-off valve and nipple from the engine intake manifold fitting.
- d. Install engine ventilation valve on the intake manifold fitting.
- e. Using a new ventilation hose, connect hose to engine ventilation valve and oil filler tube and secure each end of hose with a squeeze clamp.

33-B19. Carburetor Air Cleaner

- a. Position carburetor air cleaner on carburetor and tighten mounting clamp.
- b. Position crankcase ventilation hose on air cleaner and secure with screw clamp.

33-B20. PREVENTIVE MAINTENANCE

- a. General. If the vehicle fording kit has been properly installed, little or no maintenance is required.
- b. Maintenance Checks. The dual control cable should operate freely and with no binding or drag. When the cable knob on the instrument panel is operated, both fording valves mounted on the engine should fully open and close. All engine ventilation hoses should be checked for looseness and damage. The air inlet flexible hose and air extension tube should be checked for secure mounting and damage; also the engine exhaust extension tube should be checked for secure mounting and damage.

Note: The vehicle rear axle, front axle, transfer, transmission, bellhousing, distributor and master cylinder ventilation lines, hoses and fittings should be checked for security, damage and proper mounting.

33-B21. TESTING

- a. General.

Operational tests are performed with the engine running and the fording knob pulled to the OUT position (valves closed).

Warning: While running engine, assure that the vehicle is in a well-ventilated area or that the exhaust gases are expelled directly out of the operating area.

- b. Bellhousing Plug. Check making sure the bellhousing plug has been installed as outlined in paragraph 33-B2.
- c. Intake Air Operating Test. Remove air extension tube cap (if applicable) and cover intake tube opening with palm of hand. Engine should begin to stall. Check air intake tube connections at air cleaner flexible hose. No suction leak should exist. Check all ventilation lines leading to the air cleaner for suction leaks. No leaks should exist.
- d. Crankcase Pressure Test. Disconnect vent line from nipple of lower crank-case ventilation hose. A slight pressure should exist. If no pressure exists, proceed as follows: Hold finger over hose opening for one to two minutes and again check for pressure. If there is no pressure buildup, failure of the fording shut-off valve, mounted to the engine intake manifold, exists. If pressure does build up in a few minutes, reinstall hose coupling and using soap solution method, check all vent lines, hose and fittings leading to the bellhousing, transmission, transfer case, rear and front axles for leaks.
- e. Exhaust Operating Test. Hold block of wood wrapped in a rag (for seal) over the exhaust extension tube opening. Engine should begin to stall. Using soap solution method, check all exhaust connections for leaks.

33-B22. TROUBLESHOOTING

Malfunction	Probable Cause	Corrective Action
1. Excessive black smoke from vehicle exhaust pipe	Air cleaner or air intake tube restricted	Check air cleaner and air tube. Clean as necessary.
2. Excessive white smoke from vehicle exhaust pipe	Water seeping into engine air intake system	Check air intake system. Refer to Par. 33-B21c.
3. Loss of engine power	a. Air Cleaner or air intake tube restricted	a. Check air cleaner and air tube. Clean as necessary.
	b. Exhaust system restricted	b. Check exhaust system. Refer to Par. 33-B21e.
	c. Fuel pump ventilation line restricted	c. Disconnect vent line and clean.

4. Engine stalls in water	a. Leak in air intake system	a. Examine and tighten all air intake connections. Inspect air cleaner flexible hole. Replace if damaged.
	b. Leak in exhaust system	b. Examine and tighten all exhaust connections. Check all exhaust pipes and muffler damage. Replace damaged parts.
	c. Loose crankcase breather ventilation hose (water in crankcase)	c. Drain engine oil and refill crankcase. Examine and tighten ventilation hose clamps. Check ventilation hoses and replace as necessary.
5. Water in engine crankcase (shown by water bubbles on oil level dipstick)	a. Loose crankcase breather ventilation hose	a. Refer to 4c above.
	b. Leak in air intake system	b. Examine and tighten all air intake connections. Check air cleaner flexible hose. Replace if damaged.
6. Water in power train units (transmission, transfer case, axle housings and bellcrank housing)	a. Faulty fording shut-off valves	a. Check operation of fording valves. Refer to Par. 33-B21d.
	b. Leak in power train component vent lines	b. Check all vent lines, hose and fittings. Replace part(s) as necessary.

33-E1. 100 AMP. ALTERNATOR KIT (24-VOLT)

33-E2. DESCRIPTION

a. General

The 100 Amp. Alternator Kit (24-Volt) consists of a 100 amp. alternator, alternator drive pulley, fan belts, rectifier, rectifier support bracket assembly, regulator assembly, two shielded wiring harnesses, one cable assembly with connector, and attaching hardware (Fig. 33-E1).

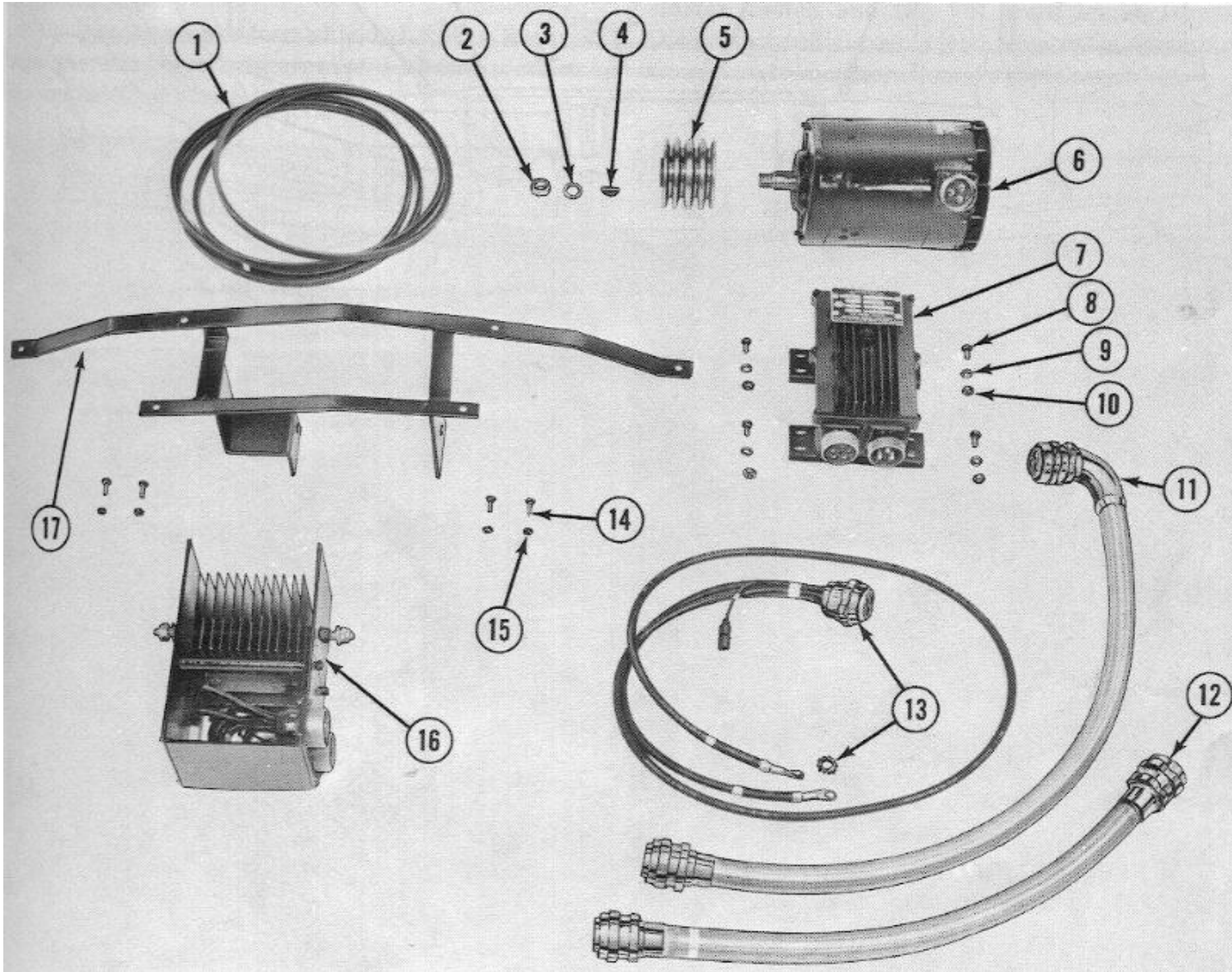

FIG. 33-EI---100 AMP. ALTERNATOR KIT (24-VOLT)

1 Fan Belts	7 Rectifier	13 Cable Assembly
2 Nut	8 Bolt	14 Bolt
3 Lock Washer	9 Lock Washer	15 Nut
4 Woodruff Key	10 Nut	16 Regulator
5 Drive Pulley	11 Long Shielded Harness	17 Mounting Bracket
6 100 Amp. Alternator	12 Short Shielded Harness	

b. 100 Amp. Alternator

The 100 amp. alternator is an engine belt driven generator and is constructed in three main functional sections: a rotor, a stator, and the brushes. The rotor revolves in the stator, suspended by prelubricated neoprene sealed ball bearings mounted in the drive end housing and contact ring end. The alternator is mounted to existing brackets on the engine and is driven by four V-belts from the engine crankshaft pulley.

c. Rectifier

The rectifier is a selenium type, and changes alternating current to direct current.

The rectifier is secured in a bracket assembly that is mounted in front of the engine radiator and secured to the upper radiator support and baffle.

d. Regulator

The regulator controls the output of the alternator and is mounted in the engine compartment to the apron of the left front fender.

e. Wiring Harnesses

Two shielded wiring harnesses are used to connect the rectifier with the alternator and regulator.

33-E3. MODIFICATIONS

Few modifications are necessary before installation of the 100 Amp. Alternator Kit (24-Volt).

33-E4. Drawing Required

A dimensional drawing (Fig. 33-E2) is required to modify, by cutting a segment of metal from the vehicle radiator upper front baffle plate to accommodate mounting of the alternator rectifier unit.

33-E5. Special Tools

No special tools or fixtures are required.

33-E6. Disposal of Discarded Parts

Disposal of all discarded parts will be in accordance with AR-755-6 or AR-755-10.

33-E7. Modification of Radiator Baffle Plate

a. Refer to Fig. 33-E2 and using scribe, lay out segment of baffle to be cut and removed. Remove brush guard.

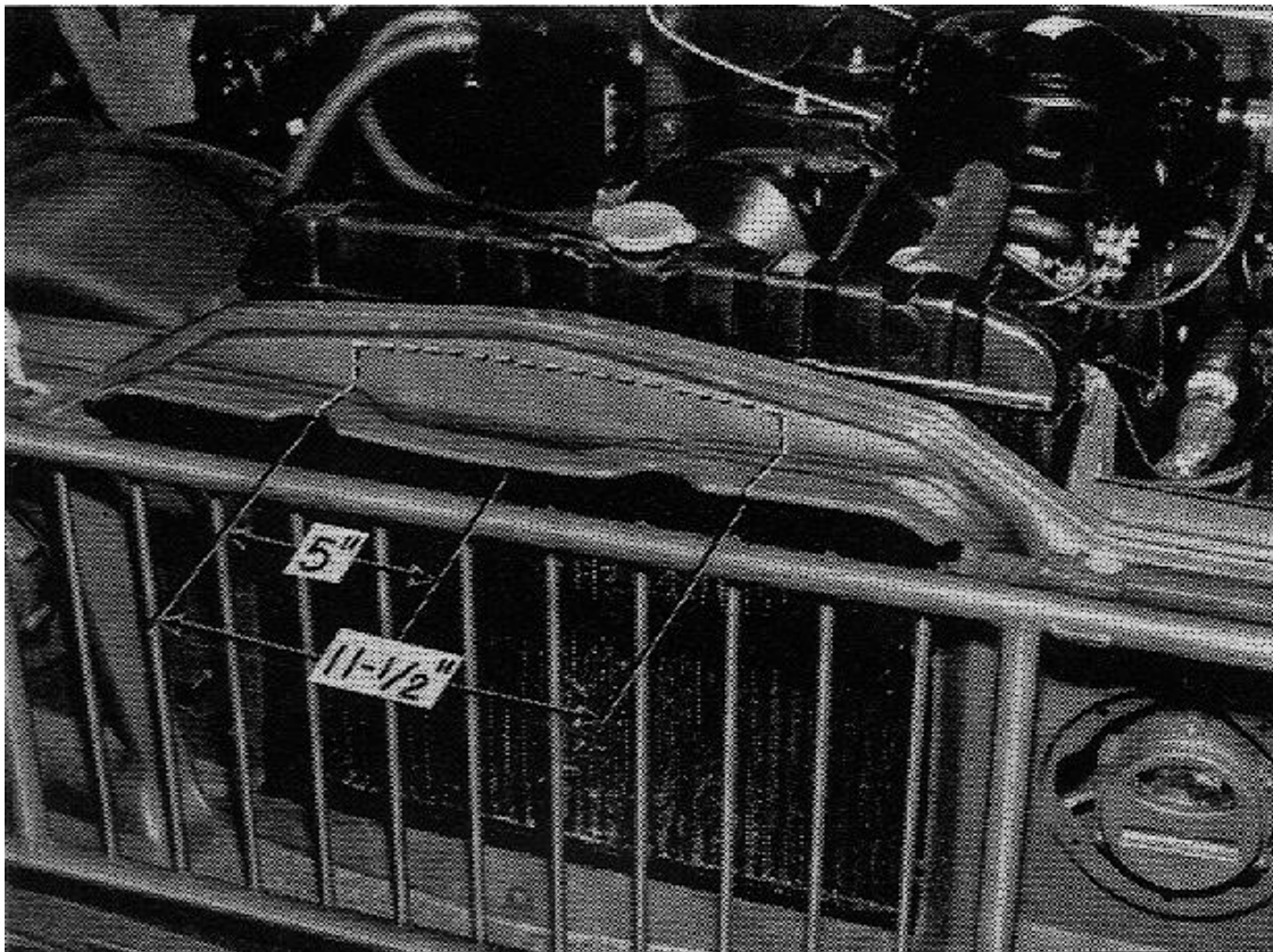

FIG. 33-E2- RECTIFIER MOUNTING LOCATION

- b. Cut material from baffle (see Fig. 33-E3).
- c. Where sharp edges of metal exist use file to dress edges smooth.
- d. Drill hole for radiator cap chain and install cotter key.

Note: Rear cut edge of baffle should be cut straight and in line with vertical plane of contour step in baffle. Edge may be hammered back to align.

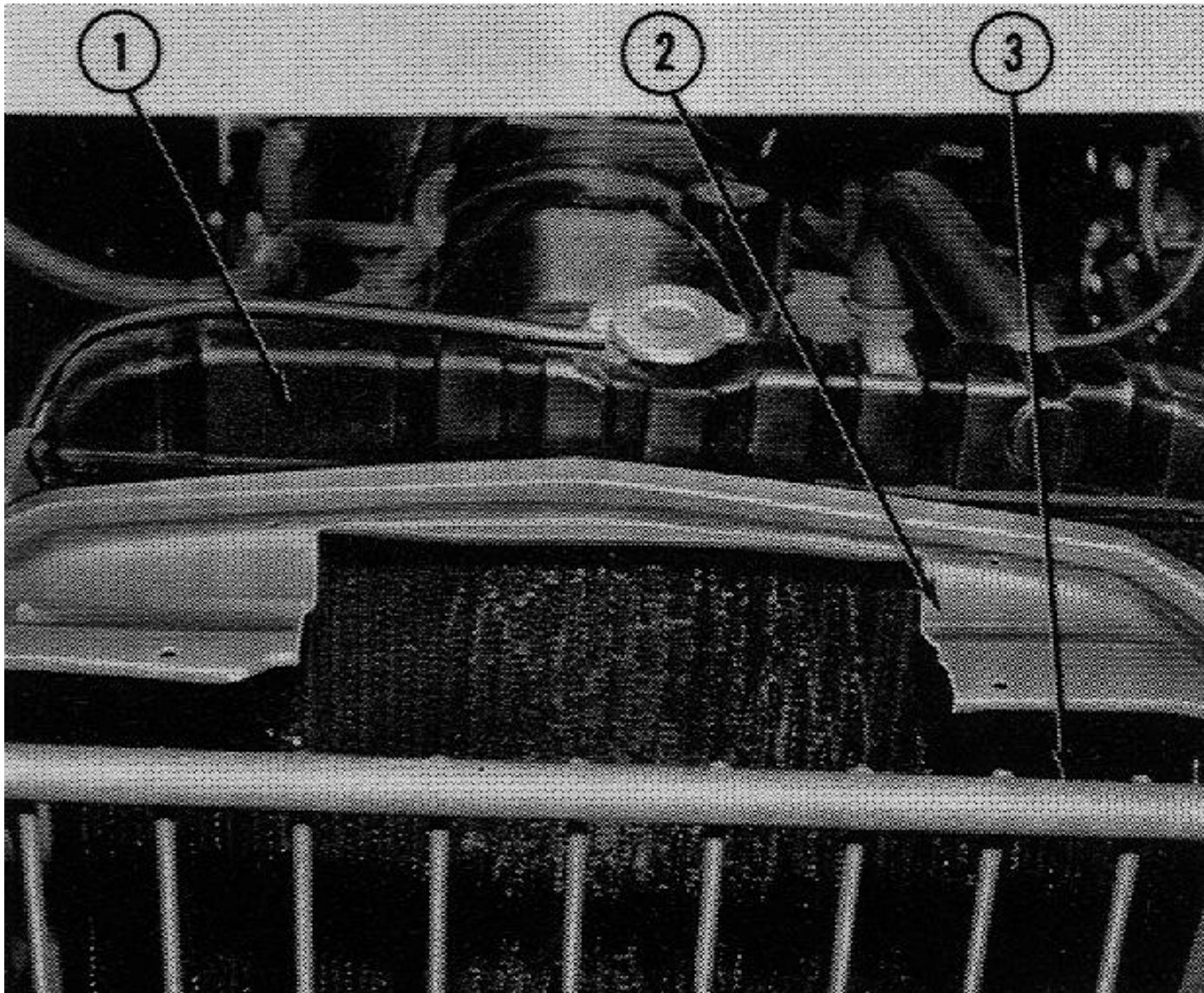

FIG. 33-E3 RADIATOR BAFFLE CUT

- 1 Radiator
- 2 Baffle
- 3 Radiator Brush Guard

33-E8. Modification of Left Front Fender

- a. Remove the horn bracket and horn from left front fender apron.
- b. Refer to Fig. 33-E4 and lay out four 9/32 dia. holes on apron of fender.
- c. Drill four 9/32 dia. holes in fender apron.

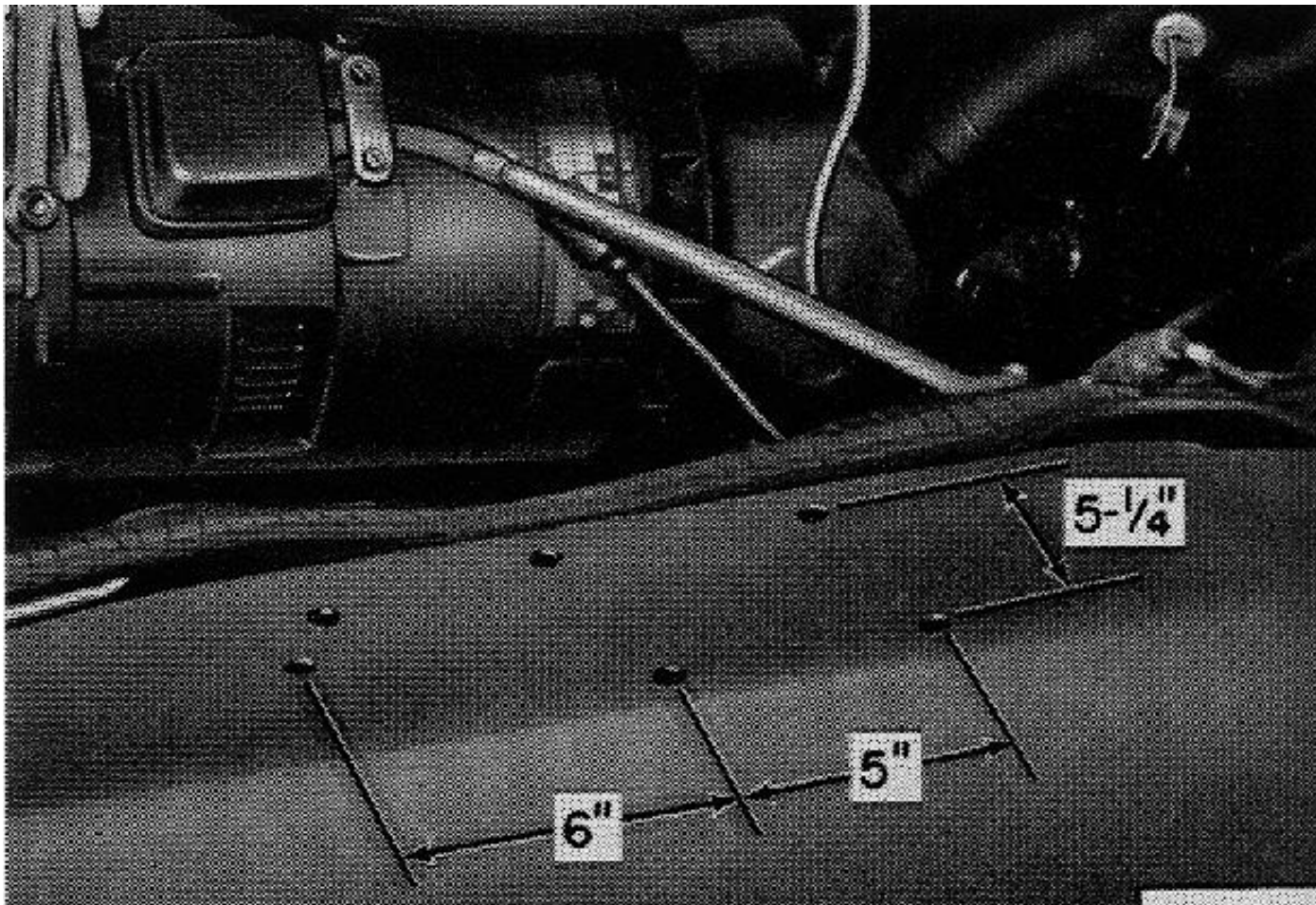

FIG. 33-E4 REGULATOR MOUNTING HOLES LOCATION

33-E9. 60 Amp. Alternator Removal

- a. Disconnect ground cable from negative battery post.
- b. Remove two screws securing wiring clamp bar and two screws securing terminal box cover to 60 amp. alternator. Remove bar and cover (Fig. 33-E5).
- c. Disconnect the smaller alternator lead wire at the waterproof connector and the larger lead wire terminal from terminal post of alternator connector box. Remove the alternator ground cable from water pump mounting bolt.
- d. Loosen alternator mounting bolts at mounting bracket of engine and remove screw and washer from alternator adjusting arm bracket.
- e. Remove the three fan belts from the engine.
- f. Remove two mounting bolts, nuts, and lock washers and remove alternator.

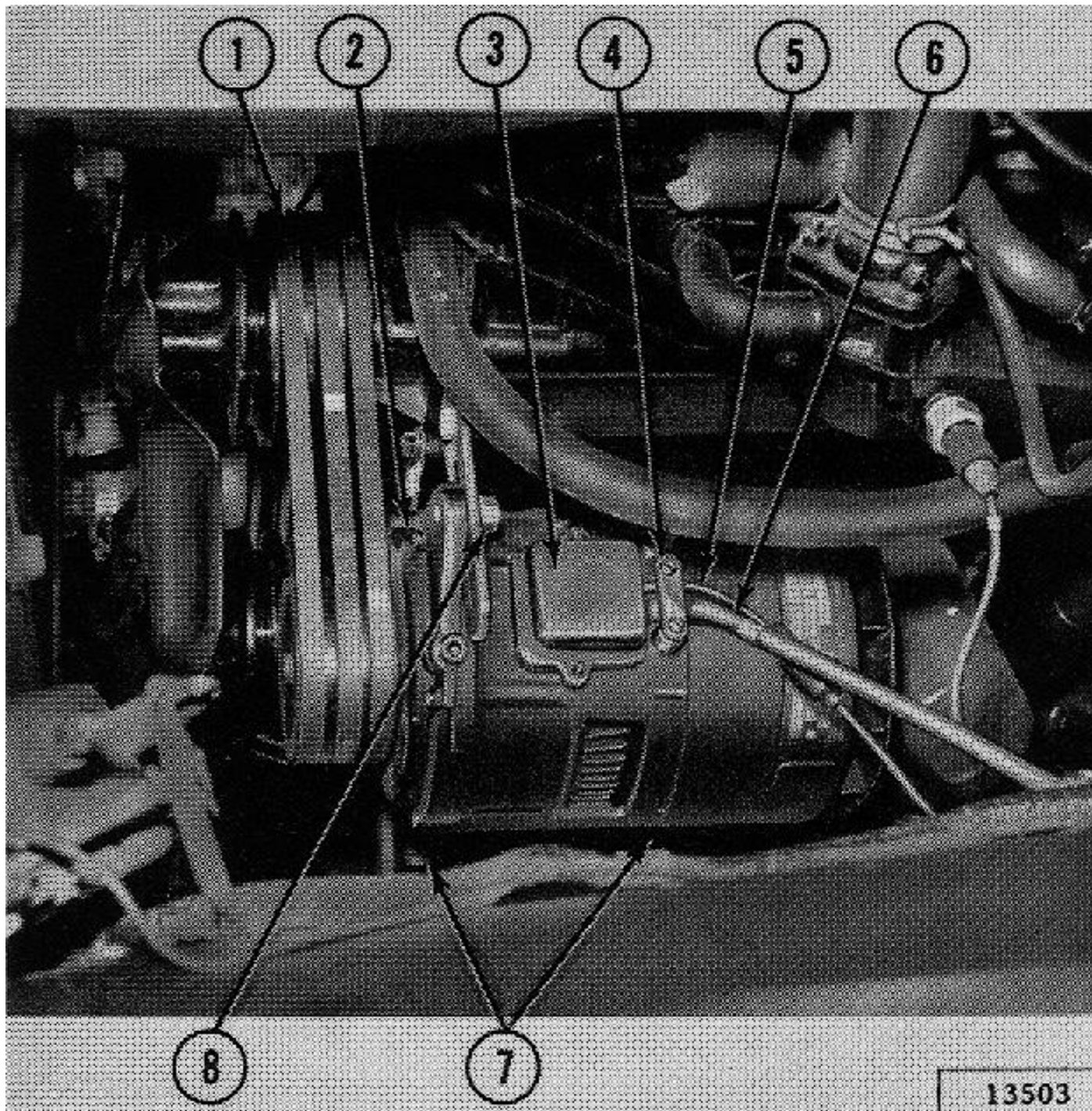

FIG. 33-E5----60 AMP. ALTERNATOR

1 Fan Belts

2 60 Amp Alternator

- 3 Terminal Box Cover
- 4 Wiring Clamp Bar
- 5 Small Lead Wire
- 6 Alternator Cable
- 7 Mounting Bolts (Hidden)
- 8 Bracket Screw

33-E 10. RECTIFIER INSTALLATION

- a. Place rectifier in mounting bracket as shown in Fig. 33-E6. Secure rectifier to bracket by tightening the right mounting nut.
- b. Remove the rectifier left mounting nut, washer and baffle bracket assembly.
- c. Remove two bolts, nuts and washers securing baffle plate to radiator support (one on each outer end of baffle plate).
- d. Place rectifier in baffle opening and secure mounting bracket to radiator baffle, position brush guard and install cap screws.

Note: Check that the rectifier is centered and touches no part of the baffle plate.

- e. When centered properly and with clearance on all sides of the rectifier, mark centers of the four existing bracket holes.
- f. Drill four 11/32" dia. holes in baffle plate and secure rectifier bracket to baffle with four 5/16 6-18x 3/4 bolts, nuts and lock washers.
- g. Working through radiator grille place the rectifier to radiator baffle bracket assembly on rectifier mounting stud and while holding bracket tight to radiator baffle plate replace nut and washer previously removed from rectifier mounting stud to secure baffle bracket in support position (refer to Fig. 33-E7).

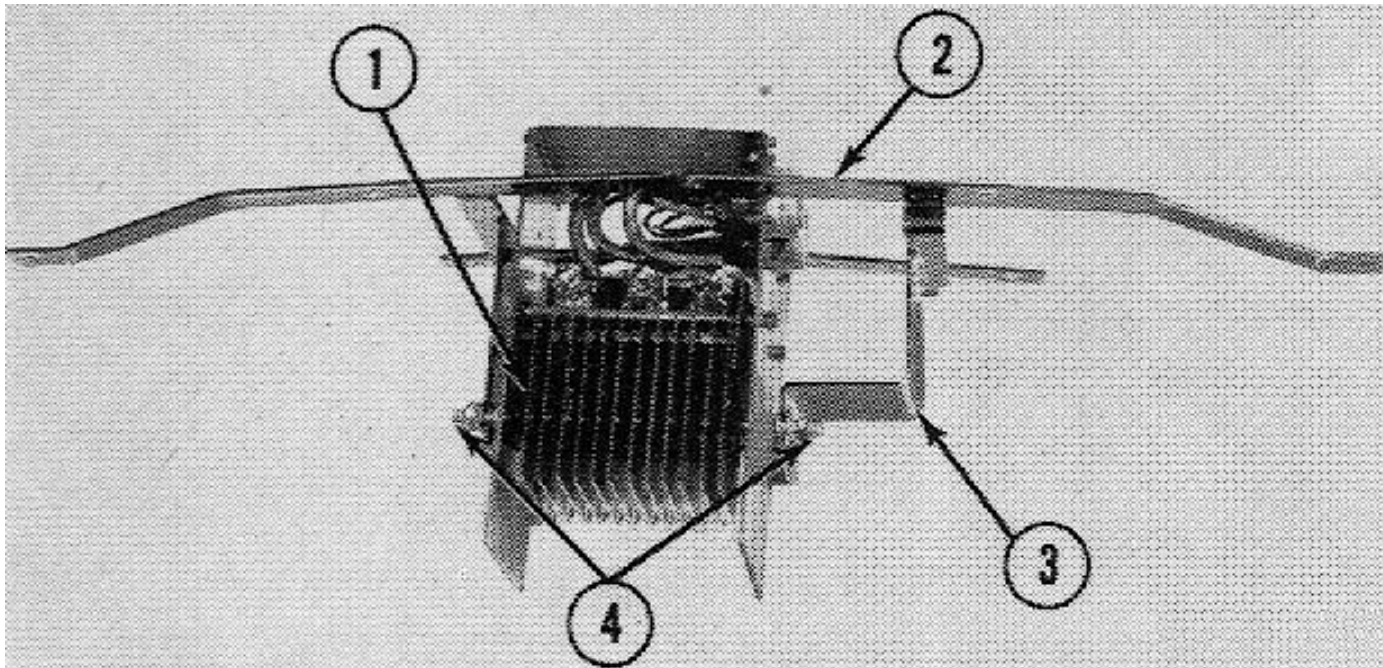
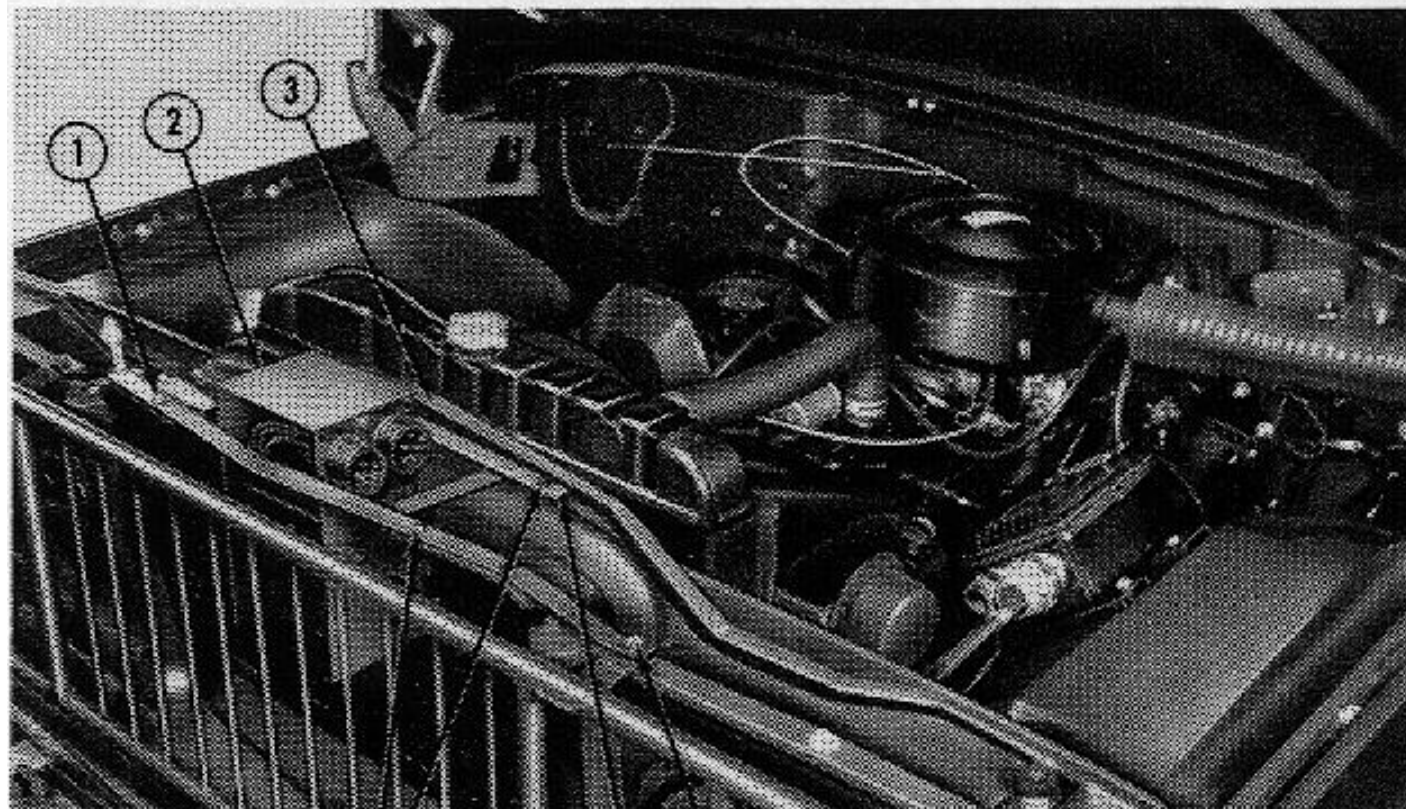
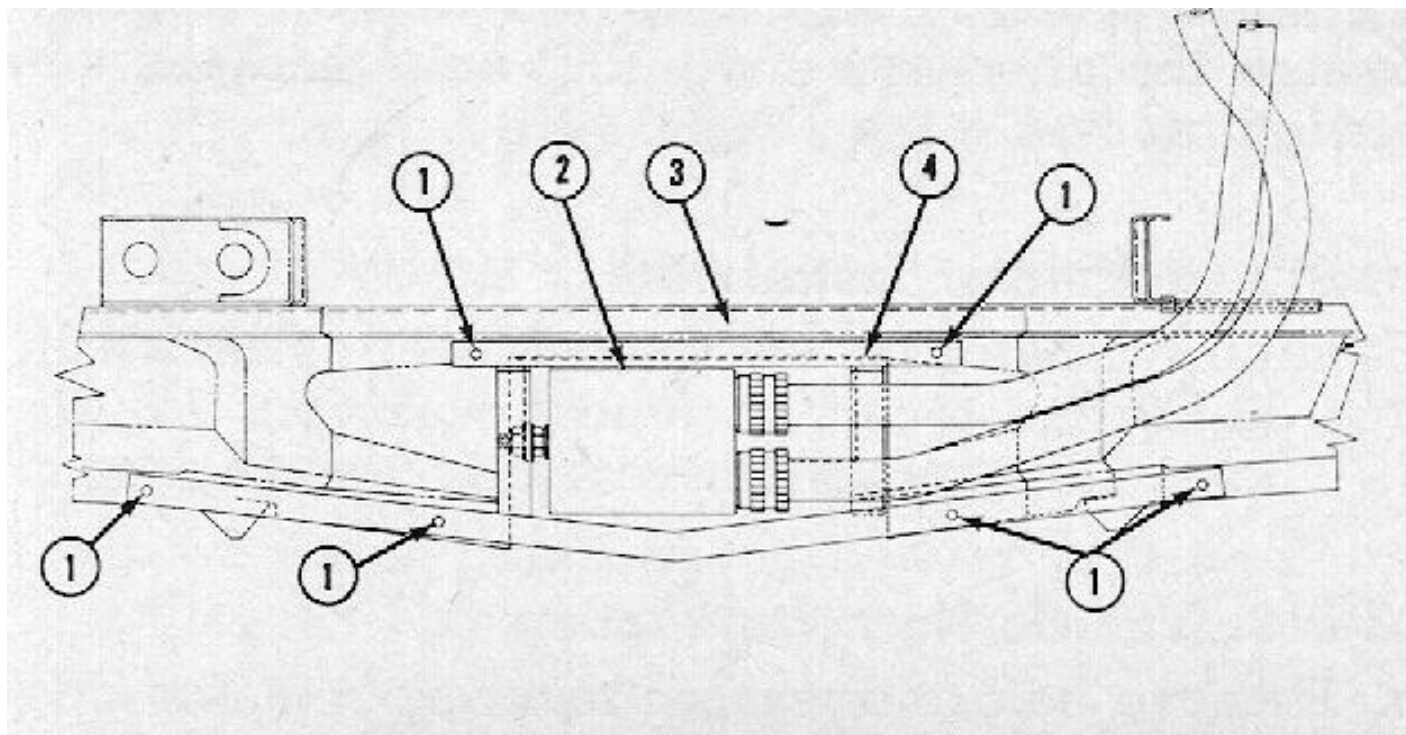

FIG. 33-E6 RECTIFIER AND MOUNTING BRACKET

- 1 Rectifier
- 2 Mounting Bracket
- 3 Baffle Bracket
- 4 Mounting Nuts



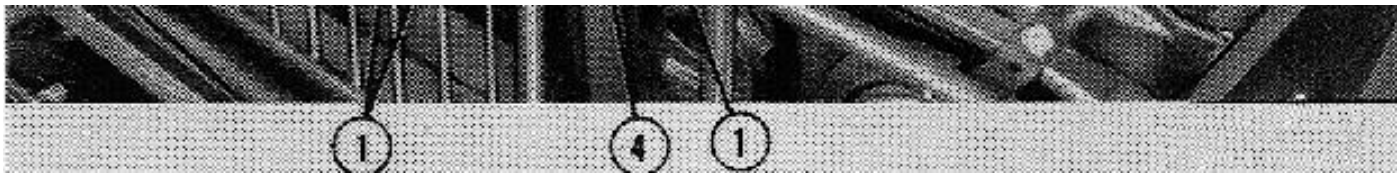

FIG. 33-E7 RECTIFIER MOUNTING

- 1 Bolts
- 2 Rectifier
- 3 Radiator Baffle
- 4 Rectifier Mounting Bracket

33-E 11 100 Amp. Alternator Installation

- a. Place the four belt drive pulley on the alternator drive shaft with woodruff key and secure in position with nut and lock washer.
- b. Position alternator on engine alternator mounting bracket and secure with two bolts, nuts and lock washers previously removed.
- c. Position the four new matched fan belts on engine and alternator pulleys. Install bolt, washer and lock washer in alternator adjusting bracket and after properly adjusting belt tension securely tighten the alternator mounting bolts and the adjusting bracket bolts (Fig. 33-E8).

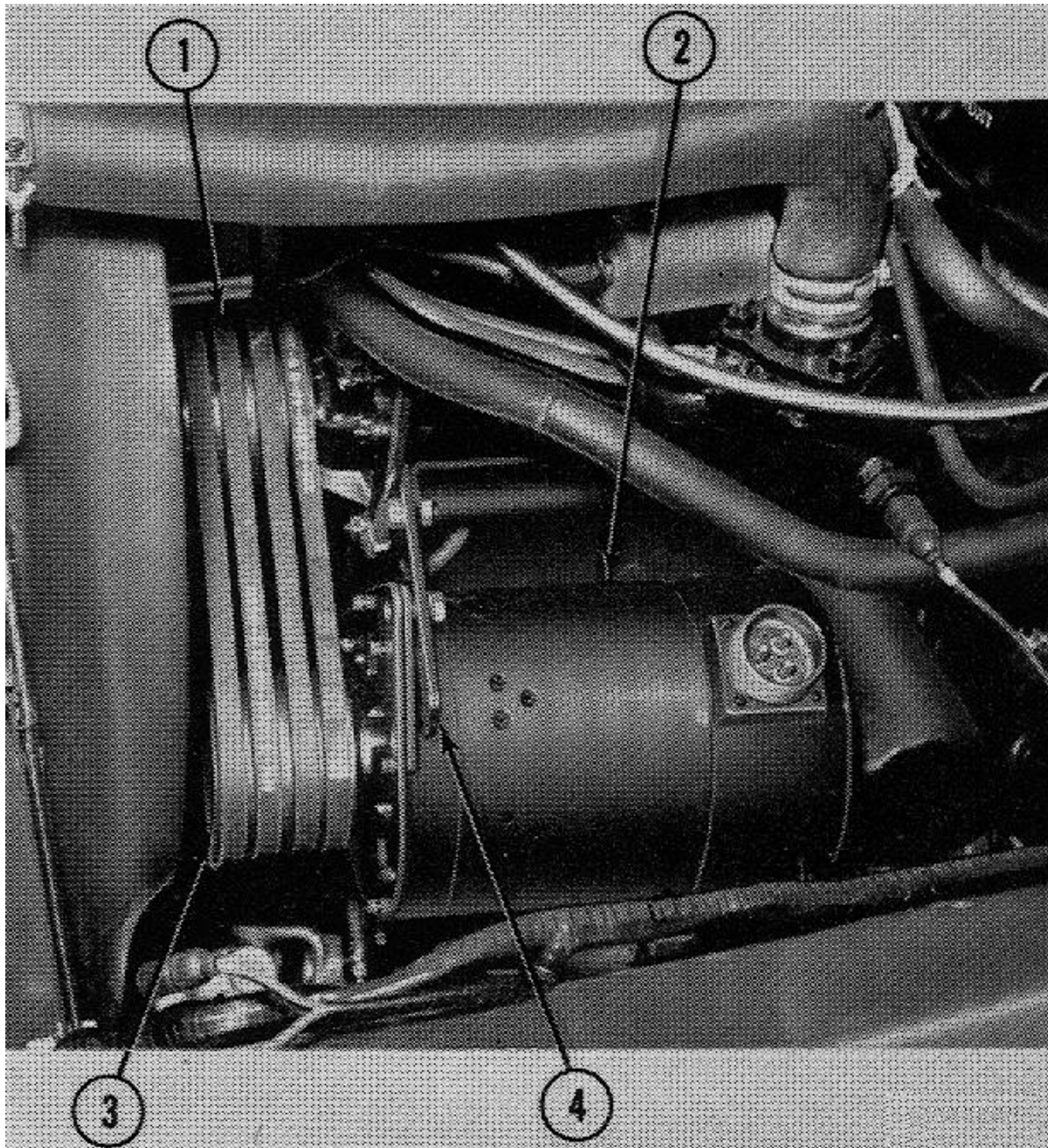

FIG. 33-E8 100 AMP. ALTERNATOR AND FAN BELTS

- 1 Fan Belt
- 2 100 Amp Alternator
- 3 Drive Pulley
- 4 Adjusting Bracket

33-E12. Regulator Installation

Position regulator on left front fender as shown in Fig. 33-E9 and secure to fender with four $\frac{1}{4}$ -20x $\frac{3}{4}$ bolts, nuts, plain washers and lock washers.

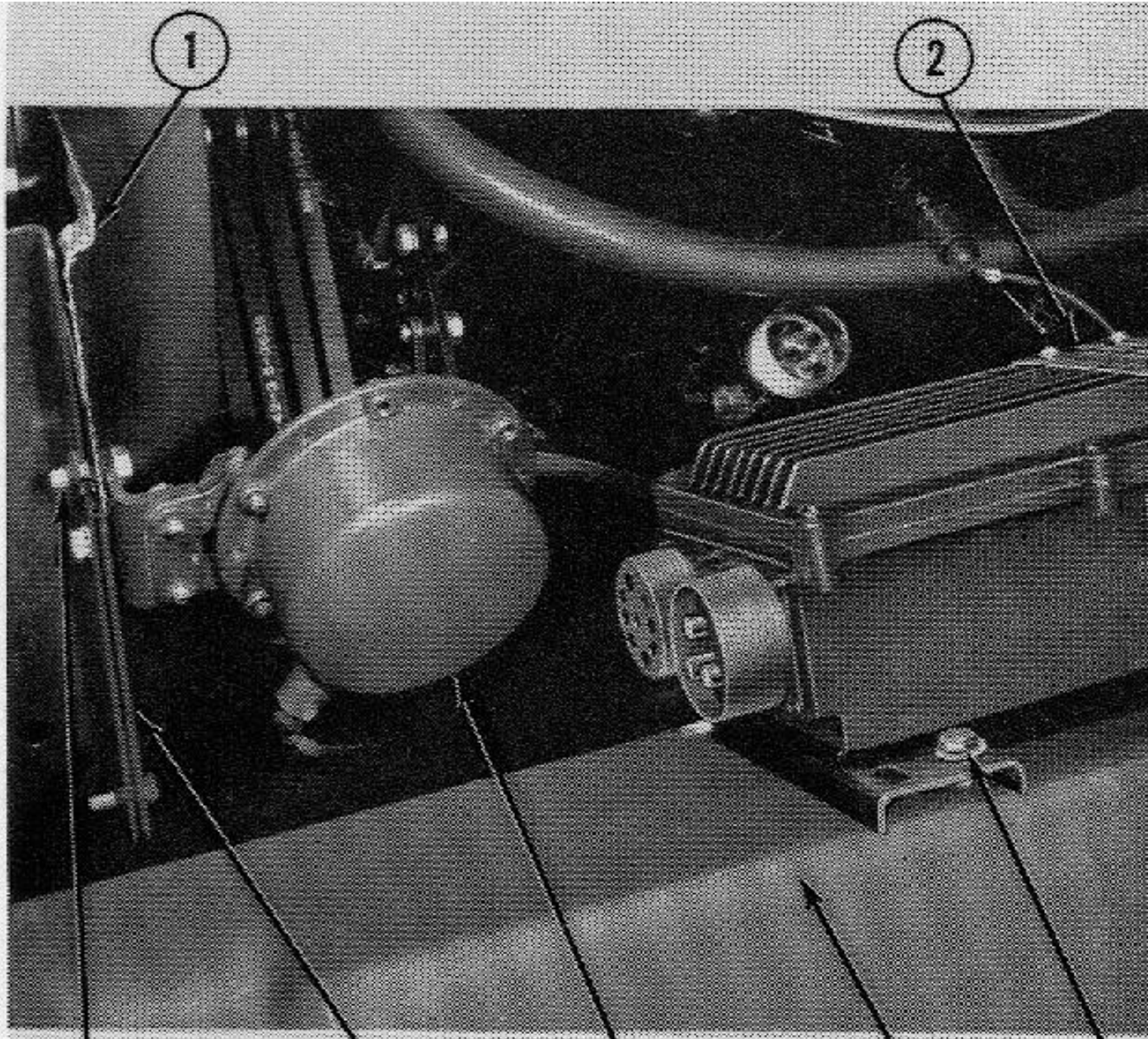



FIG. 33-E9 REGULATOR AND HORN MOUNTING

- 1 Radiator Side Baffle
- 2 Regulator
- 3 Mounting Bolt
- 4 Fender Apron
- 5 Horn
- 6 Radiator Support
- 7 Baffle to Support Bolt

33-E 13. Vehicle Horn Installation

a. Remove bolt and washer securing radiator side baffle to radiator support bracket. Hold horn bracket top hole against hole in baffle and mark location of lower bracket hole. Drill 9/32" dia. hole in baffle and support and enlarge upper horn bracket hole to 11/32" dia. to facilitate replacement of previously removed 5/16" bolt. Secure horn bracket to radiator baffle and support using the one existing 5/16" bolt and washer and one 5/16-18x 3/4 bolt, nut and lock washer (see Fig. 33-E9).

33-E14. Wiring Harnesses

- a. Connect the shortest shielded wiring harness to the rectifier and regulator.
- b. Connect the longest shielded wiring harness to the rectifier and 100 amp. alternator as shown in Fig. 33-E10.
- c. Place pinch weld chafings strips under shielded cables at positions shown in Fig. 33-E10.
- d. Secure cable assembly connector to regulator and connect shortest cable (ground) to right front engine support using existing bolt and nut. Place a lock washer under the cable terminal when connecting cable to engine support.

Note: Engine support must be cleaned of all paint and grease at mating surface of cable.

Position the longest cable (positive battery) parallel to the existing alternator cable and attach the cable terminal to the positive (hot) post of the engine starter switch (battery lead cable connecting post). Clip cable to main wiring harness.

- e. Cut terminal from existing 60 amp. alternator cable and fold cable end back on cable and using electrical tape, tape off end.
- f. Connect the existing 60 amp. alternator lead to the connector of the short lead of the cable assembly. Refer to Fig. 33-E10.
- g. Connect ground cable to battery negative post. Refer to Fig. 33-E11 for correct wiring connections checking.
- h. Secure the lighting harness to the underside of the radiator baffle in the area of the baffle cut-out. Use the 10 long perforated strap and fastener in the kit. Wrap around baffle and harness.

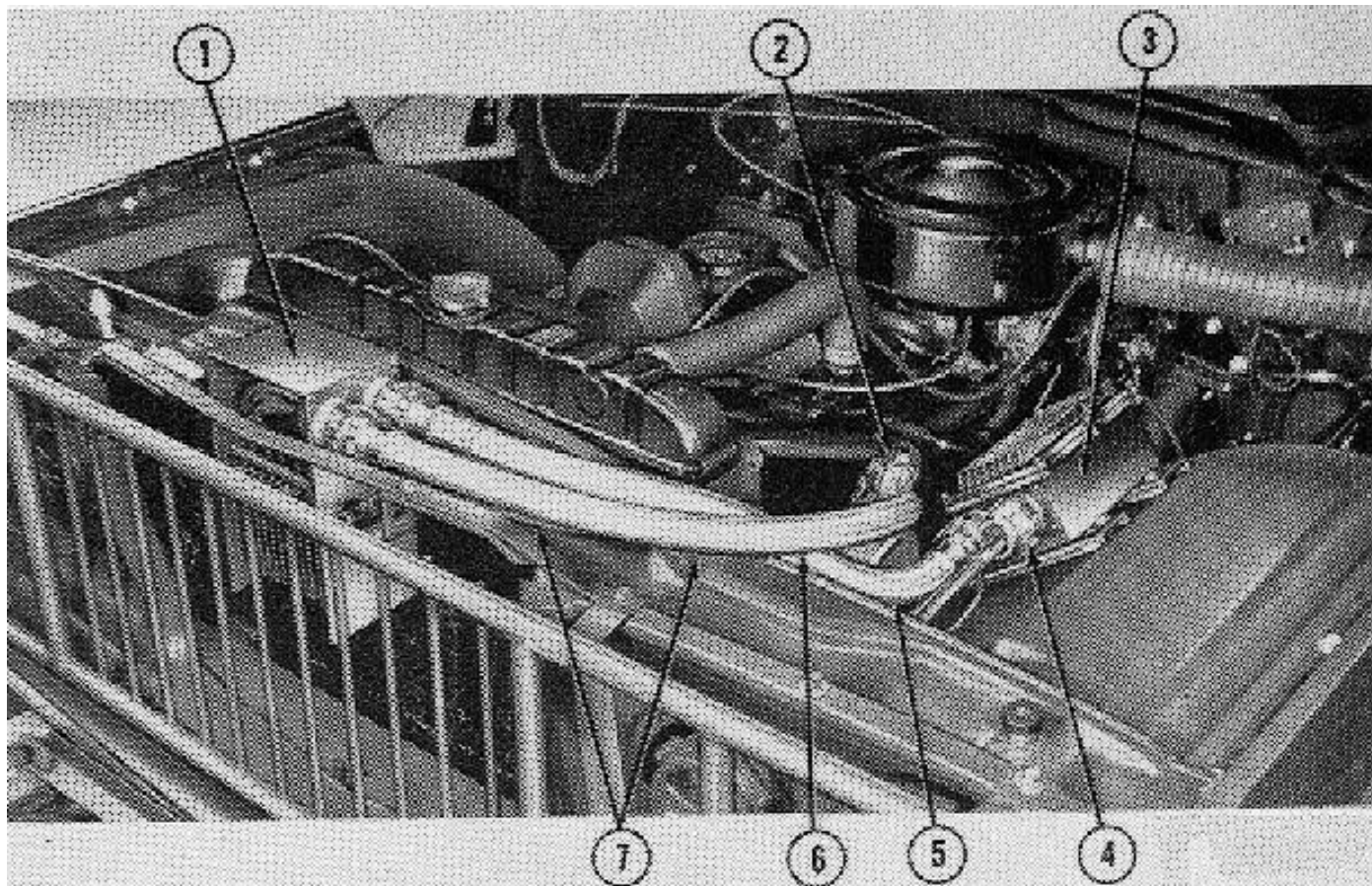

FIG. 33-E 10 WIRING HARNESES

- 1 Rectifier
- 2 100 Amp. Alternator
- 3 Regulator
- 4 Cable Assembly
- 5 Short Wiring Harness
- 6 Long Wiring Harness
- 7 Chafing Strip

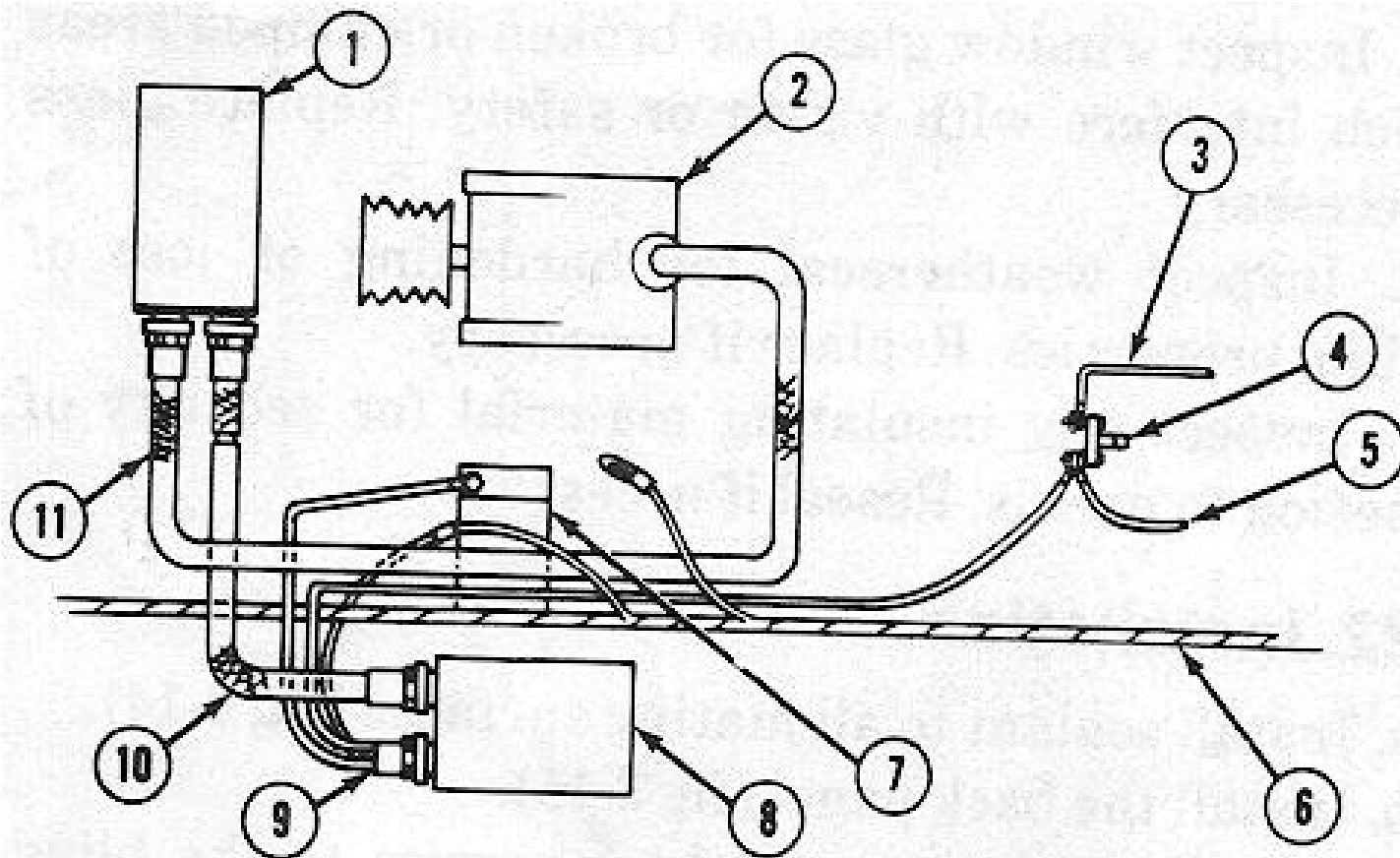

FIG. 33-E11 100 AMP. ALTERNATOR KIT WIRING CONNECTIONS

1 Rectifier	5 Battery Lead Cable	9 Battery to Regulator
2 Alternator	6 Vehicle Harness	10 Alternator to Rectifier Shielded Harness
3 Starter Cable	7 Motor Support Bracket	11 Regulator to Rectifier Shielded Harness
4 Starter Switch	8 Regulator	

33-E15. REMOVAL OF 100 AMP. ALTERNATOR KIT (24-VOLT)

33-E16. Removal of Wiring Harnesses

- Disconnect battery ground cable from battery negative post.
- Disconnect the long shielded wiring harness from the 100 amp. alternator and the rectifier. Remove shielded harness.
- Disconnect the short shielded wiring harness from the rectifier and the regulator mounted on the fender apron. Remove shielded harness.
- Remove the two pinch weld chafing strips from top left side of radiator upper front baffle.
- Disconnect cable assembly connector from regulator then disconnect the cables from the engine starter switch and the left front engine support. Disconnect vehicle cable lead from cable assembly at waterproof connector. Remove cable assembly.

33-E17. Rectifier

- a. Remove four bolts, nuts and lock washers securing the rectifier mounting bracket to the radiator top baffle.
- b. Remove two bolts, nuts and lock washers securing the rectifier mounting bracket to the radiator baffle and support. Remove the rectifier and mounting bracket assembly. Reinstall the two bolts, nuts and lock washers securing the radiator baffle to the radiator support. Tape the light wiring harness to the center section of the radiator baffle.

33-E18. Regulator

Remove the four bolts, nuts and lock washers securing the regulator to the left front fender apron. Remove regulator from vehicle.

33-E19. 100 Amp. Alternator

- a. Loosen alternator mounting bolts at mounting bracket of engine and remove bolt, washer and lock washer from alternator adjusting arm bracket.
- b. Remove the four fan belts from the engine.
- c. Remove the two mounting bolts, nuts and lock washers and remove alternator.

33-E20. Replacement of 60 Amp. Alternator

- a. Retrieve 60 amp. alternator and three matched fan belts from storage.
- b. Position alternator on engine alternator mounting bracket and secure with two bolts, nuts and lock washers previously removed.
- c. Position the three matched fan belts on the engine and alternator pulleys. Install bolt, washer and lock washer in alternator adjusting bracket and after properly adjusting the belt tension securely tighten the alternator mounting bolts and the adjusting bracket bolts.
- d. Connect short lead of vehicle existing wiring harness to waterproof connector of alternator lead.
- e. Untape end of existing vehicle alternator cable and install terminal on cable end. Position terminal on terminal post of alternator terminal box after removing cover from box. Reinstall cover on terminal box and secure cable and lead wire under alternator clamp bar. Connect ground cable to water pump and alternator.
- f. Connect battery ground cable to battery negative post.

33-E21. PREVENTIVE MAINTENANCE

- a. Check water pump and generator belt tension. All (4) belts should have approximately ½ inch free play.
- b. Check generator, regulator, rectifier, and mounting bracket screws, bolts, and nuts for tightness.
- c. Check making sure all cable connectors are tight. Check for breaks in conduits and harnesses.
- d. Check battery cables for tightness and condition. Tighten, clean, or replace, as required.
- e. Using hydrometer check condition of batteries. All cells of the batteries should read 1.275 to 1.300 at 80°F. If a reading of 1.220 or below is found the battery should be recharged or replaced.
- f. Check rectifier. If dirty clean with a soft brush or dry cloth.

Caution: Use care not to scratch or damage the coating on the rectifier plates.

- g. Turn ignition switch on, battery-generator indicator hand should move to the yellow band. Start engine and allow engine to reach normal operating temperature, then observe battery-generator indicator. With engine operating at approximately 1,500 rpm the indicator hand should stay in the green band. Turn the engine ignition off and if the indicator hand does not return to the yellow position, troubleshoot the entire generating system.

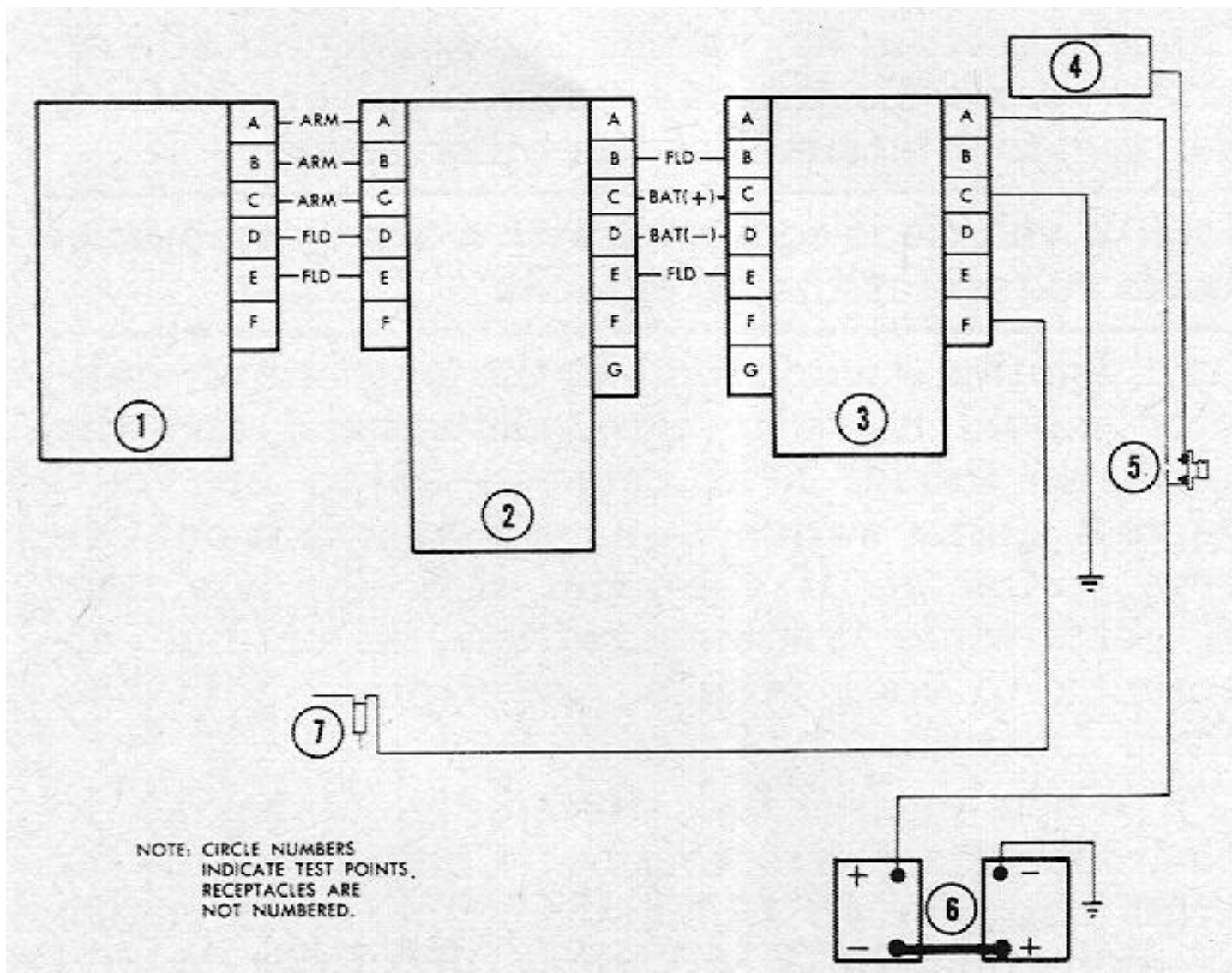

FIG. 33-E12 WIRING DIAGRAM 100 AMP. ALTERNATOR KIT

- 1 Alternator
- 2 Rectifier
- 3 Regulator
- 4 Starter Motor
- 5 Starter Switch
- 6 Batteries
- 7 Ignition Switch

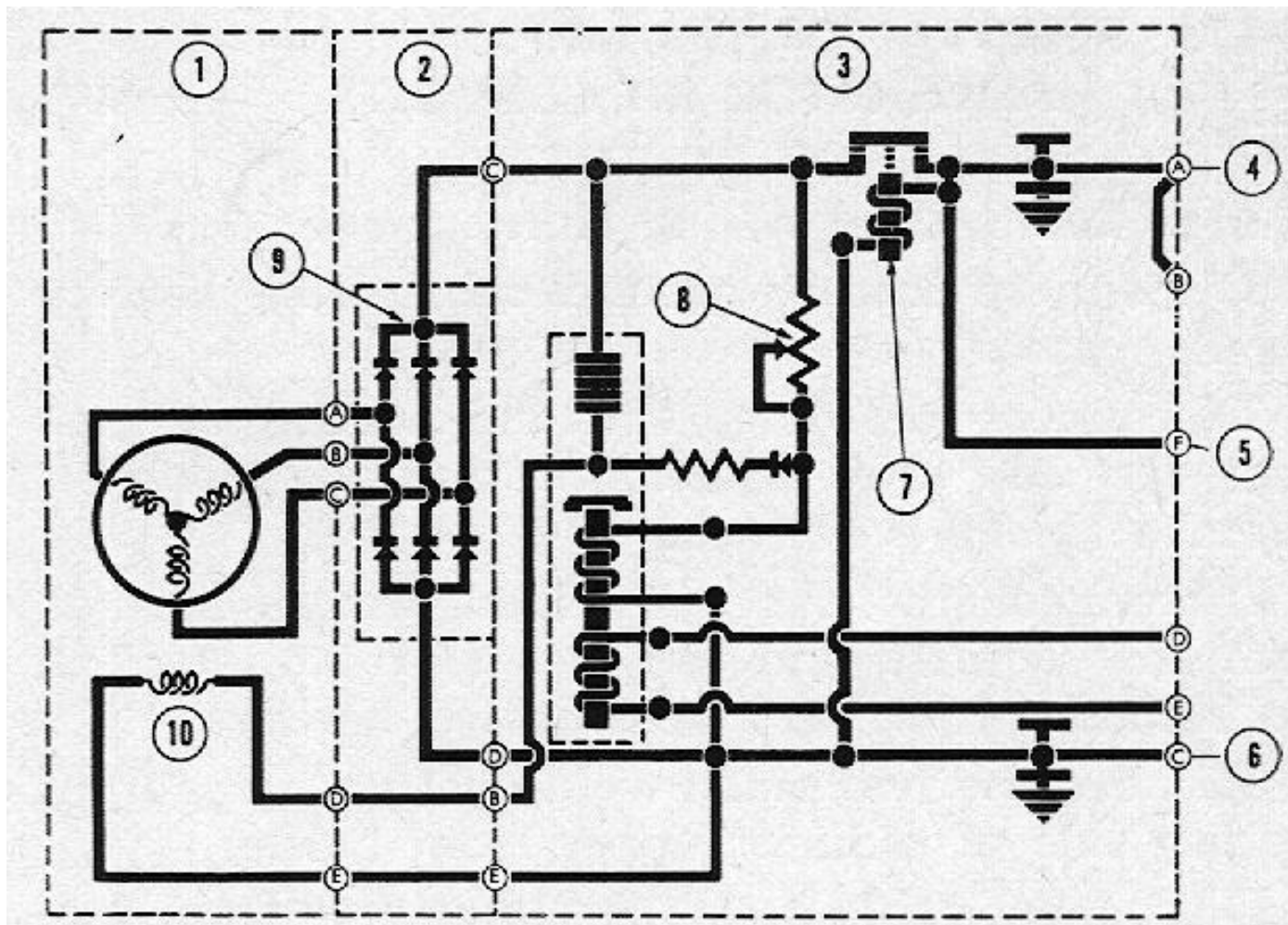

FIG. 33-E13 SCHEMATIC DIAGRAM 100 AMP. ALTERNATOR KIT

- 1 Alternator
- 2 Rectifier
- 3 Regulator
- 4 Battery (+)
- 5 Ignition Switch
- 6 Ground
- 7 Line Switch
- 8 Voltage Rheostat
- 9 Power Rectifier
- 10 Field

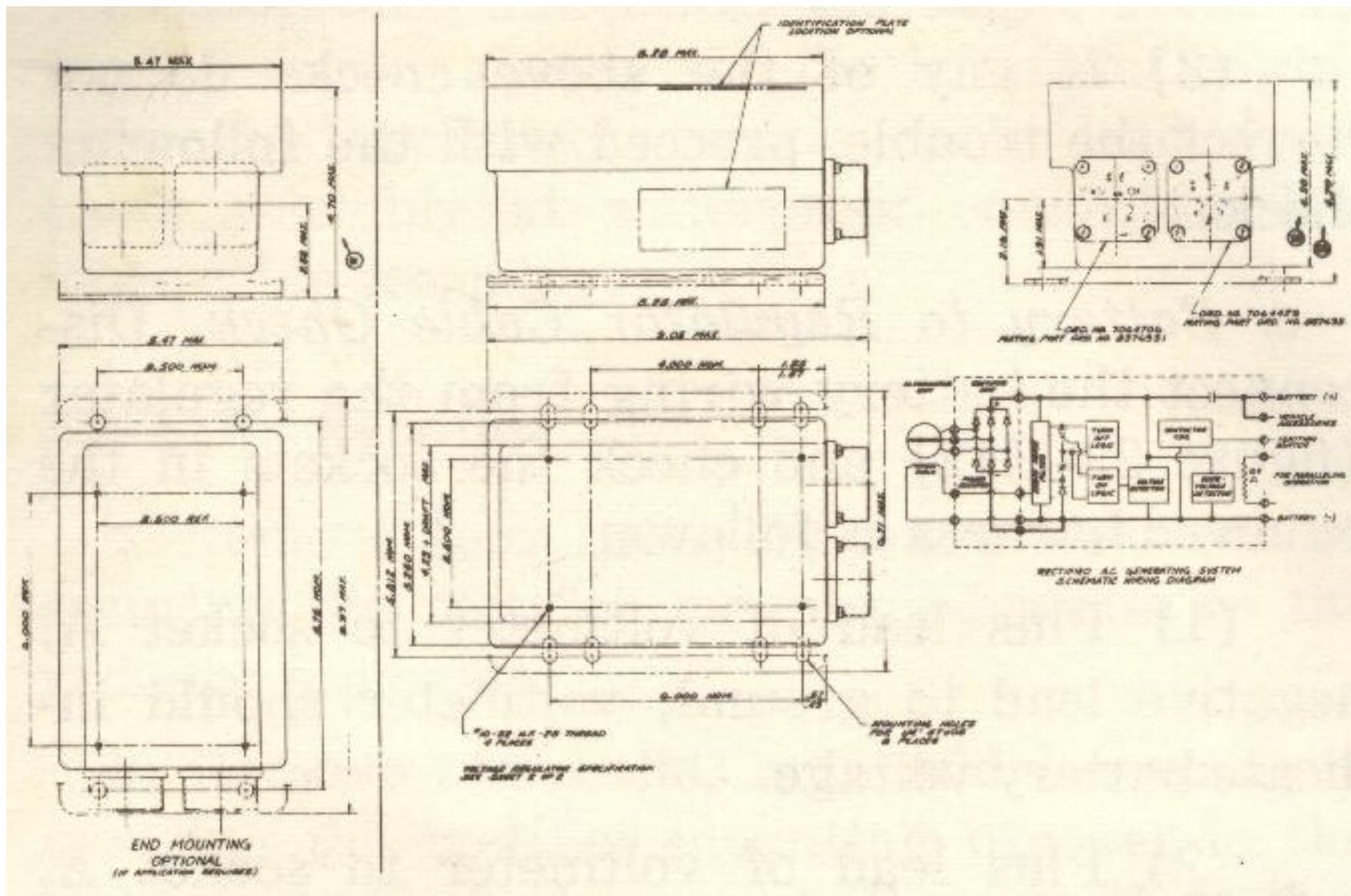

FIG. 33-E14 SCHEMATIC DIAGRAM 100 AMP. ALTERNATOR KIT

NOTE: This image has lots of information on it that is hard to read until the image is made rather large. I have linked a large version of the image here:

[LARGE FIG. 33-E14 SCHEMATIC DIAGRAM 100 AMP. ALTERNATOR KIT](#)

33-E22. TESTING

a. Tests. The following tests should be performed when troubleshooting the 100 ampere generating system.

b. Voltage Output Test. Refer to Fig. E-12.

(1) Connect a dc voltmeter, having a 50-volt range, across the positive terminal of one battery and negative terminal of the other battery.

Note: If vehicle is equipped with a slave receptacle, check voltage at the receptacle.

Turn ignition switch on. Battery-generator indicator should move to the yellow band and the voltmeter should read between 23 to 25 volts. Depress starter switch with ignition switch on. Observe voltmeter. If voltmeter indicates less than 18 volts while cranking starter, discontinue attempting to start vehicle, and replace both batteries. Disconnect voltmeter.

(2) When engine has started, allow engine to reach operating temperature. Connect voltmeter across batteries (b (1) above) and bring engine to approximately 1,500 rpm. Voltmeter should indicate between 27.5 to 28 volts, and batterygenerator indicator should be in the green band. Turn on lights and any load not exceeding 100 amperes. Voltage should be constant and remain at 27.5 to 28 volts. If voltage drops below 27.5 volts, or exceeds 28 volts during the test, adjust the regulator voltage (c below).

Note: It is normal for the ac generator unit to whine or howl.

c. Regulator Voltage Adjustment. Remove plug from top or side of regulator. Using a screwdriver, turn the voltage adjusting rheostat (Fig. 33-E13) in clockwise direction to increase voltage and in counterclockwise direction to decrease voltage. Rheostat should not allow more than a 5-volt range in its adjustment and voltage is to remain stable.

d. Visual Checks

(1) Check security of all connectors and that wiring is not damaged.

(2) If rectifier is dirty, clean with soft brush or dry cloth.

Caution: Exercise care not to scratch or damage the coating on the rectifier plates.

(3) If any of the above checks do not correct the trouble, proceed with the following checks.

e. Battery to Regulator Cable Check. Disconnect the battery wiring from the regulator (Fig. 33-E12) and check the sockets in the removed harness as follows:

(1) Plus lead of voltmeter to socket A, negative lead to ground; voltmeter should indicate battery voltage.

(2) Plus lead of voltmeter to socket A, negative lead to socket B; voltmeter should indicate battery voltage.

(3) Plus lead of voltmeter to socket F, negative lead to socket C (ignition switch on), voltmeter should indicate battery voltage. If battery voltage is indicated in each test, connect harness connector to regulator. If battery voltage is not indicated, inspect for damaged connectors, sockets, and wiring. Repair or replace harness as required.

f. Regulator to Rectifier Lead and Conduit Check.

Disconnect connector at the rectifier and make the following checks at the sockets of the disconnected lead and conduit connector.

(1) Place positive lead of voltmeter to socket C and negative lead to ground with ignition switch on. Voltmeter should indicate battery voltage.

(2) Place positive lead to socket B and negative lead to ground with ignition switch on. Voltmeter should indicate battery voltage.

(3) Place positive lead to socket C and negative lead to socket E with ignition switch on. Voltmeter should indicate battery voltage

Note: If battery voltage readings are not obtained during these tests, disconnect the lead and conduit from the regulator and check continuity of conduit wires using an ohmmeter. If lead and conduit is defective, replace. If wiring is not at fault, regulator is defective. Replace regulator. Connect lead and conduit to regulator and rectifier using suitable tools.

g. Alternator to Regulator Lead and Conduit Check. Disconnect the generator to regulator lead and conduit at the generator and perform the following checks at the disconnected connector of the lead and conduit.

(1) Place positive lead of voltmeter to socket D and negative lead to socket E with ignition switch on. Voltmeter should indicate battery voltage.

(2) Connect negative lead of voltmeter to ground, and with positive lead contact in, turn sockets A, B, and C with ignition switch on. No voltage should be indicated on the voltmeter. If voltage readings are as specified in d through f above, and visual checks do not locate the trouble, perform the alternator tests which follow.

h. Alternator Tests. Proceed as follows:

Caution: Perform the following checks with all electrical power on the vehicle off (ignition switch off) to prevent damage to the ohmmeter. Disconnect the conduit connector from the alternator if not already disconnected. Set ohmmeter to low ohm scale (R x 1) and make the following checks at the alternator and alternator receptacle.

- (1) Check three-phase winding continuity. Connect ohmmeter leads to pins A and B, then to pins A and C, and finally to pins C and B. Ohmmeter should indicate no resistance (closed circuit).
- (2) Check field resistance. Set ohmmeter selector to R x 1 scale. Connect ohmmeter leads to pins D and E of alternator receptacle. Meter should read less than 4 ohms. To assure that brushes are contacting the slip rings, and rings are clean throughout all points of contact, remove the fan belts from the alternator and rotate the rotor at least five times by hand. Ohmmeter reading should be constant and remain at approximately 4 ohms or less. Install belts and adjust.
- (3) Check for ground. With ohmmeter set on the ohms scale (R x 100) check from pins A, B, and C to the generator housing or case (ground). Ohmmeter should read infinite resistance (open circuit).
- (4) Test Generator to Rectifier Lead and Conduit. Connect conduit connector at generator receptacle and disconnect the same conduit at the rectifier. Repeat the tests made on the generator receptacle on the pins of the connector of the disconnected conduit. Results of tests should be the same; if not, conduit is defective. Repair or replace conduit as required. If the above tests do not locate the trouble continue to the next test.

i. Rectifier Tests

- (1) Test reverse current resistance. With the ignition switch off, disconnect both lead and conduits at the rectifier. Set the ohmmeter to the high ohms scale (R x 100) and connect the positive lead to pin D on the rectifier-to-regulator receptacle of the rectifier. Touch the other lead to each of the three large sockets (A, B, and C) in turn on the rectifier-to-generator receptacle of the rectifier. Record meter readings. A variation of more than 25 ohms between any two readings indicates a faulty rectifier. This test checks one side of the rectifier. To test the other side, place the negative lead of the ohmmeter on pin C of the rectifier-to-regulator receptacle and again touch the other lead to each of the three large sockets (A, B, and C) of the rectifier-to-generator receptacle. Record the three readings. The variation between any two readings should not exceed 25 ohms. In addition, the variations between any two readings in both sides of the rectifier should not be more than 25 ohms.
- (2) Test continuity of field circuit through rectifier. With ohmmeter set on the high ohms scale (R x 100), check from the small pin B to socket D, and from the small pin E to socket E on the rectifier receptacles. Ohmmeter should indicate no resistance.
- (3) Test lead and conduits. Connect both lead and conduits to the rectifier. Disconnect the same conduits at their opposite ends (at regulator and generator). Repeat tests (1) and (2) above through the conduits. The results should be the same. When finished with tests, disconnect both lead and conduits completely and check each for grounding. Set ohmmeter on high ohm scale (R x 100) and check each pin to the metal shielding; ohmmeter should indicate infinite resistance. If no grounding is found, connect both lead and conduit assemblies and secure each, using suitable tools. If internal grounding is found, replace the lead and conduits as necessary.

33-E23. TROUBLESHOOTING

Caution: Reversing polarity of battery will burn rectifier.

Malfunction	Probable Cause	Corrective Action
No Output	a. Broken or loose belts	a. Adjust or replace belts.
	b. Generator seized	b. Replace generator.
	c. Burned rectifier	c. Replace rectifier.
	d. Disconnected wire	d. Tighten all wire connections.
	e. Defective regulator	e. Replace regulator.
	f. One or both batteries dead	f. Replace dead batteries.
Low output; less than 27.5 volts	a. Loose belts	a. Adjust belts.
	b. Burned rectifier	b. Replace rectifier.
	c. Loose connection	c. Tighten connector.

	d. Regulator out of adjustment	d. Adjust voltage rheostat or replace regulator.
	e. One phase shorted on alternator	e. Replace alternator.
	f. One or both batteries dead	f. Replace dead batteries.
High output; more than 28.5 volts	a. One or both batteries low charge	a. Replace low charge batteries.
	b. Regulator out of adjustment	b. Adjust voltage rheostat or replace regulator.
	c. Wire shorted	c. Check wiring, repair as necessary.
Battery generator indicator hand stays in red or yellow band with engine running at 1500 rpm	a. Faulty indicator	a. Replace indicator.
	b. Broken connection	b. Check wiring repair as necessary.
	c. No output of generating system	c. See items 1 and 2 above.
	d. One or both batteries dead	d. Replace dead batteries.
	e. Low voltage setting	e. Adjust voltage rheostat.
Belt squeal	a. Glazed belts	a. Install new belt set.
	b. One or more worn or damaged belts	b. Install new belt set.
	c. Generator seized	c. Replace generator.
	d. Loose belts	d. Adjust belt tension.
	e. Seized water pump	e. Replace water pump.
Batteries use too much water	a. High voltage setting	a. Adjust voltage rheostat.
	b. Cracked battery case	b. Replace battery.
Battery does not hold charge	a. Voltage limiter incorrectly adjusted	a. Adjust voltage rheostat.
	b. One or both batteries dead	b. Replace dead batteries.
	c. Charging system not functioning	c. Perform tests and make adjustments or replacements as necessary.
	d. Slipping belts	d. Adjust belt tension.
Rectifier burned	a. Faulty rectifier	a. Replace rectifier.
	b. Insufficient cooling due to dirt or plates	b. Replace rectifier.
	c. Air flow to rectifier blocked by foreign object	c. Remove foreign object and replace rectifier.
	d. Too high voltage	d. Adjust voltage rheostat and install new rectifier.

33-E24. GENERATOR CHARACTERISTICS

Amps. 100

Volts 28

Watts 2800

Speed Range 1650 to 8000 rpm.

Water proof construction.

Radio noise suppressed.

Operating Temp. 70°F to 160°F.

Weight 37.7 lbs.

Part No. 7954720 Pulley 943789

Used with regulator No. 8699744

Belts Matched Set (4)

Total Length 42

The maximum wattage dissipation of the carbon pile of the regulator is 90 watts.

The minimum resistance of the carbon pile of the regulator is 0.5 ohms.

The maximum resistance of the carbon pile of the regulator is 40 ohms.

The regulator is radio noise suppressed and is fungus resistant.

33-E25. REGULATOR CHARACTERISTICS

Weight 11.25 lbs

Amps. 100

Volts 28

Water proof Construction

Operating Temperature Range

(Minus) 70°F to + 160°F.

The range of line voltage adjustment by means of the voltage adjusting rheostat 24 to 29 volts.

33-E26. RECTIFIER CHARACTERISTICS

Rated volts 28

Rated amperes 100

Weight 11.2 lbs

33-A1. ARCTIC ENCLOSURE KIT

33-A2. DESCRIPTION

The Arctic Enclosure Kit (Fig. 33-A1) is a metal and glass enclosure designed to protect the vehicle cab and crew from weather extremes and at the same time provide maximum comfort and vision. It consists of a roof panel and a back panel which attach to the body and each other with common bolts, nuts, and screws. Both panels are fabricated with insulation installed. The back panel is equipped with a window glass, assembled to the panel with weatherstripping. Weatherseals are supplied loose with the kit for the cab door openings. Sealant for all mating surfaces is furnished with the kit.



FIG. 33-A1- ARCTIC ENCLOSURE KIT, INSTALLED

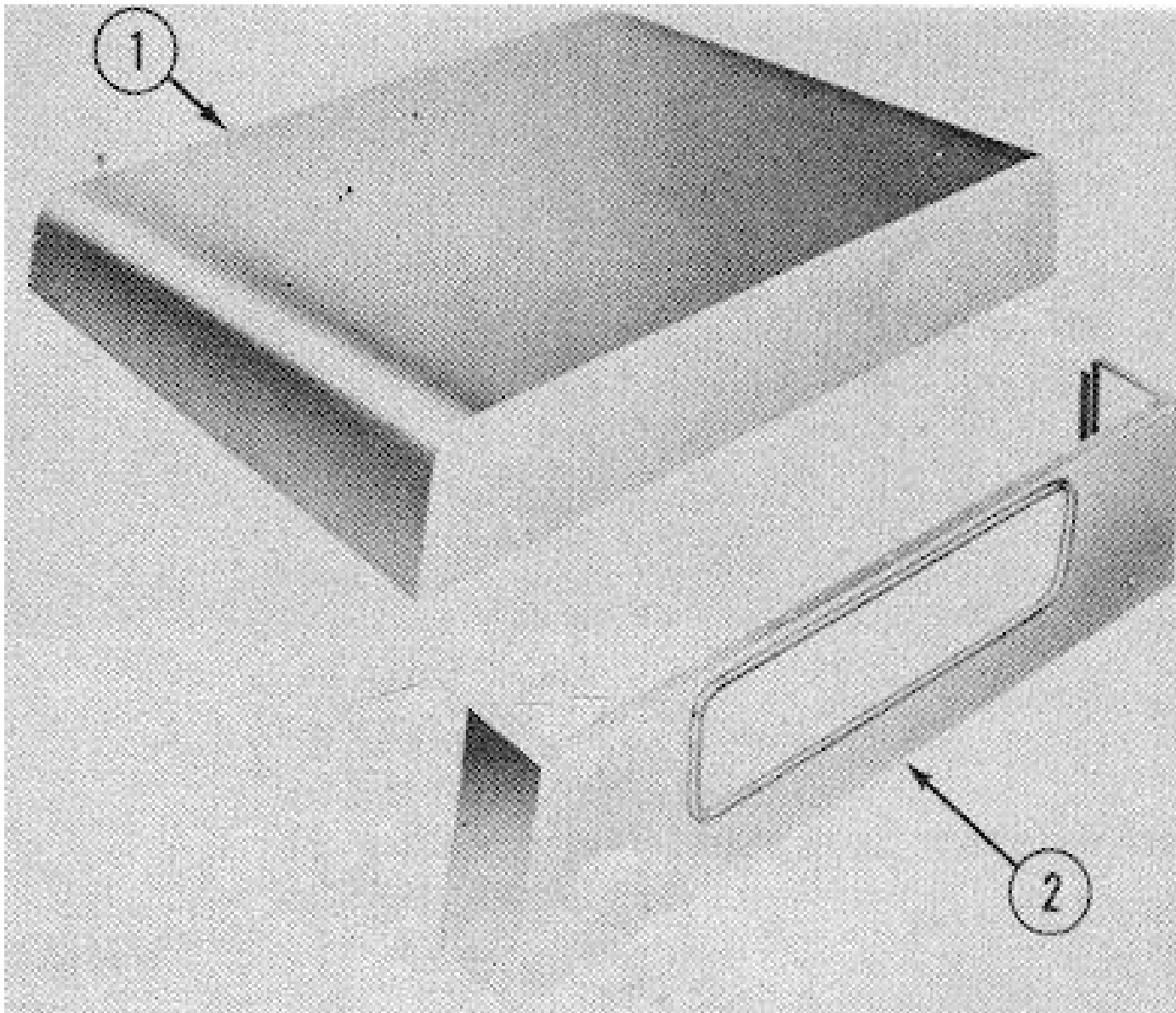

FIG. 33-A2 ARCTIC ENCLOSURE KIT

1 Roof Panel Assembly Including Insulation

2 Back Panel Assembly Including Insulation, Glass and Weatherstrip

Note. The following items are also included in the kit.

(1) Roll Sealant 18 Feet Long

(11) 1/4-20 x 1 3/4" Truss Head Machine Screw

(6) 1/4-20 x 1 1/4" Truss Head Machine Screw

(4) 1/4-20 x 1/2" Truss Head Machine Screw

(13) 1/4-20 x 1/2" Hex Head Machine Screw

- (34) 1/4-20 "Eslok Locknut
- (7) 1/4-20 x 1 Hex Head Machine Screws
- (7) 1/4-20 Jack Nuts
- (2) Weatherseals Door Front Upper
- (2) Weatherseals Door Top and Rear
- (1) Jack Nut Installation Wrench

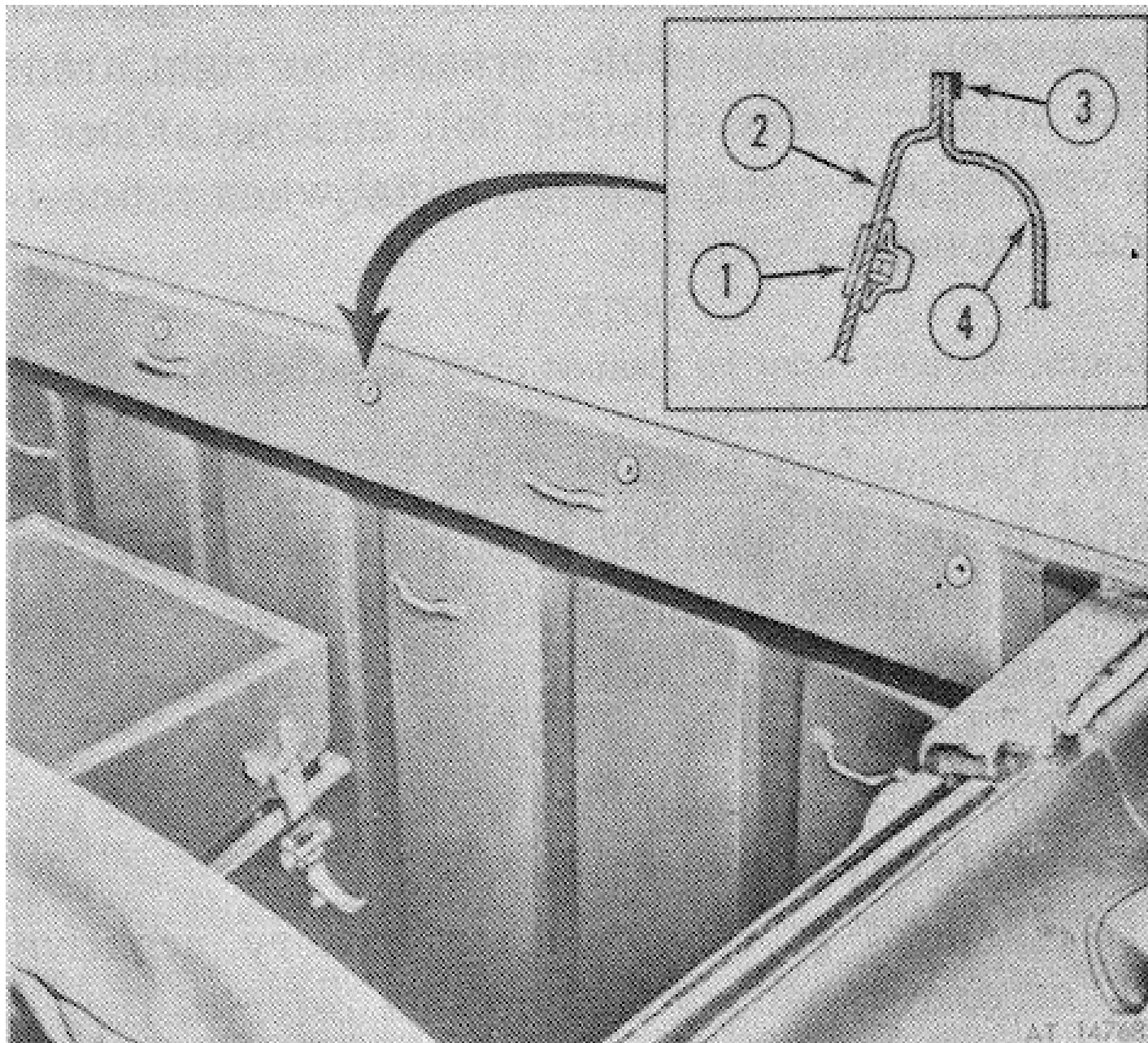

33-A3 VEHICLE BACK PANEL PREPARATION

- 1 Jack Nut Installed
- 2 Body Back Panel Reinforcement
- 3 Sealant
- 4 Body Back Panel

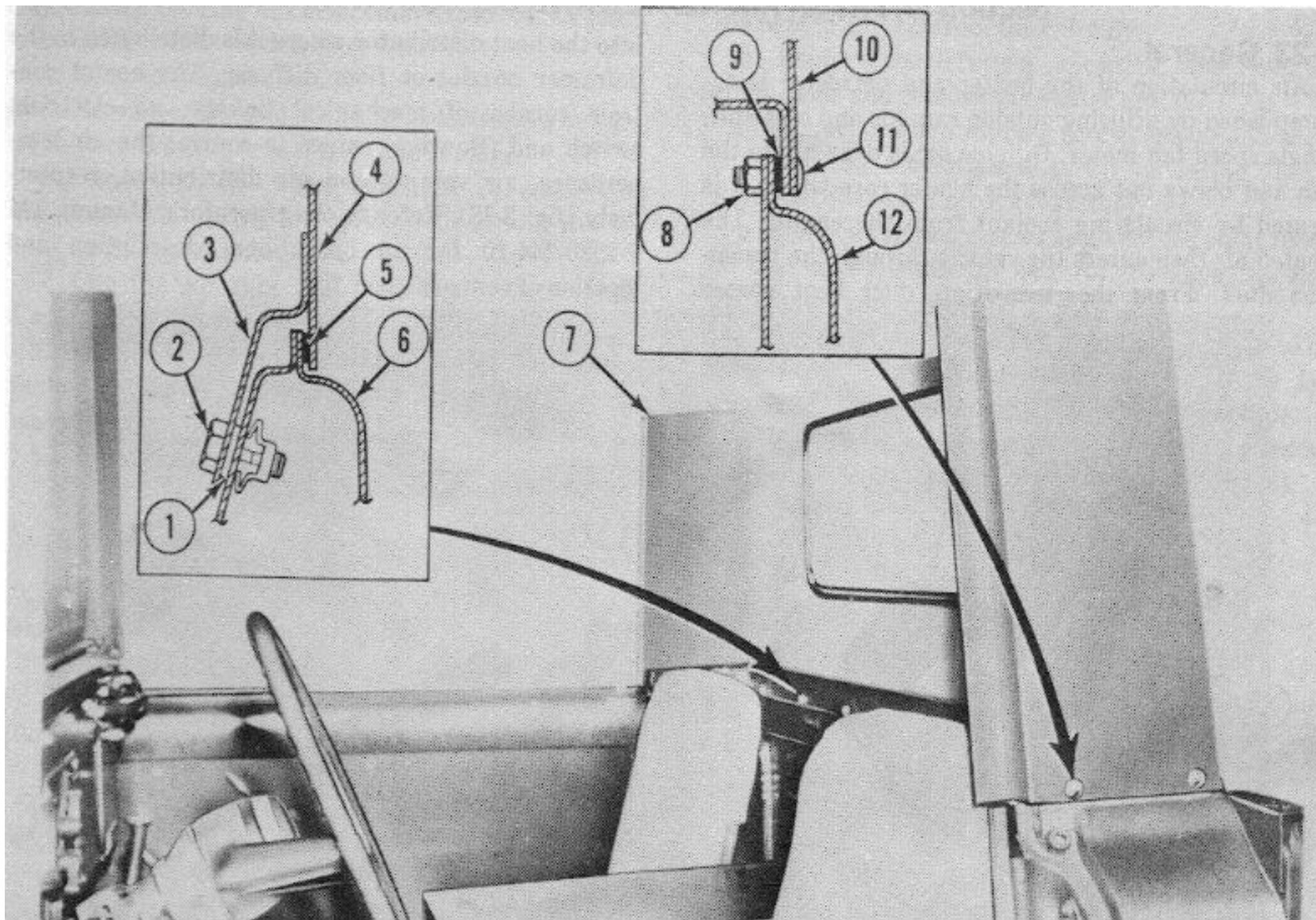

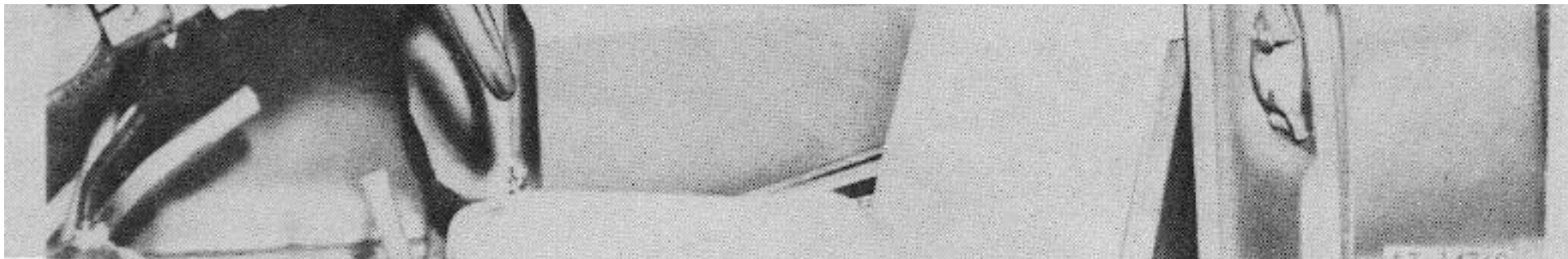

FIG. 33-A4 ARCTIC KIT BACK PANEL INSTALLED

- 1 Jack Nut
- 2 1/4-20 x 1 Hex Head Machine Screw
- 3 Kit Back Panel Mounting Flange
- 4 Kit Back Panel
- 5 Sealant
- 6 Body Rear Panel
- 7 Kit Back Panel
- 8 Locknut
- 9 Sealant
- 10 Kit Back Panel (Side)
- 11 1/4-20 x 1/2 Truss Head Machine Screw
- 12 Body Panel (Side)

33-A3. VEHICLE MODIFICATION

The vehicle shall be modified as necessary to install the Arctic Enclosure Kit. Modifications consist of drilling holes in the vehicle cab body and windshield frame.

33-A4. DRAWINGS REQUIRED

There are no drawings or special templates required for vehicle modification.

33-A5. SPECIAL TOOLS, JIGS, AND FIXTURES REQUIRED

Jack Nut Installation Wrench.

33-A6. DISPOSAL OF DISCARDED PARTS

Discarded parts will be disposed of in accordance with AR-755-6 or AR-755-10.

33-A7. PREPARATION OF VEHICLE

To prepare the vehicle cab for installation of the Arctic Enclosure Kit, remove the canvas top, roof bows and supporting framework, weatherseal from windshield flanges, and pinch welt from flange around rear of cab.

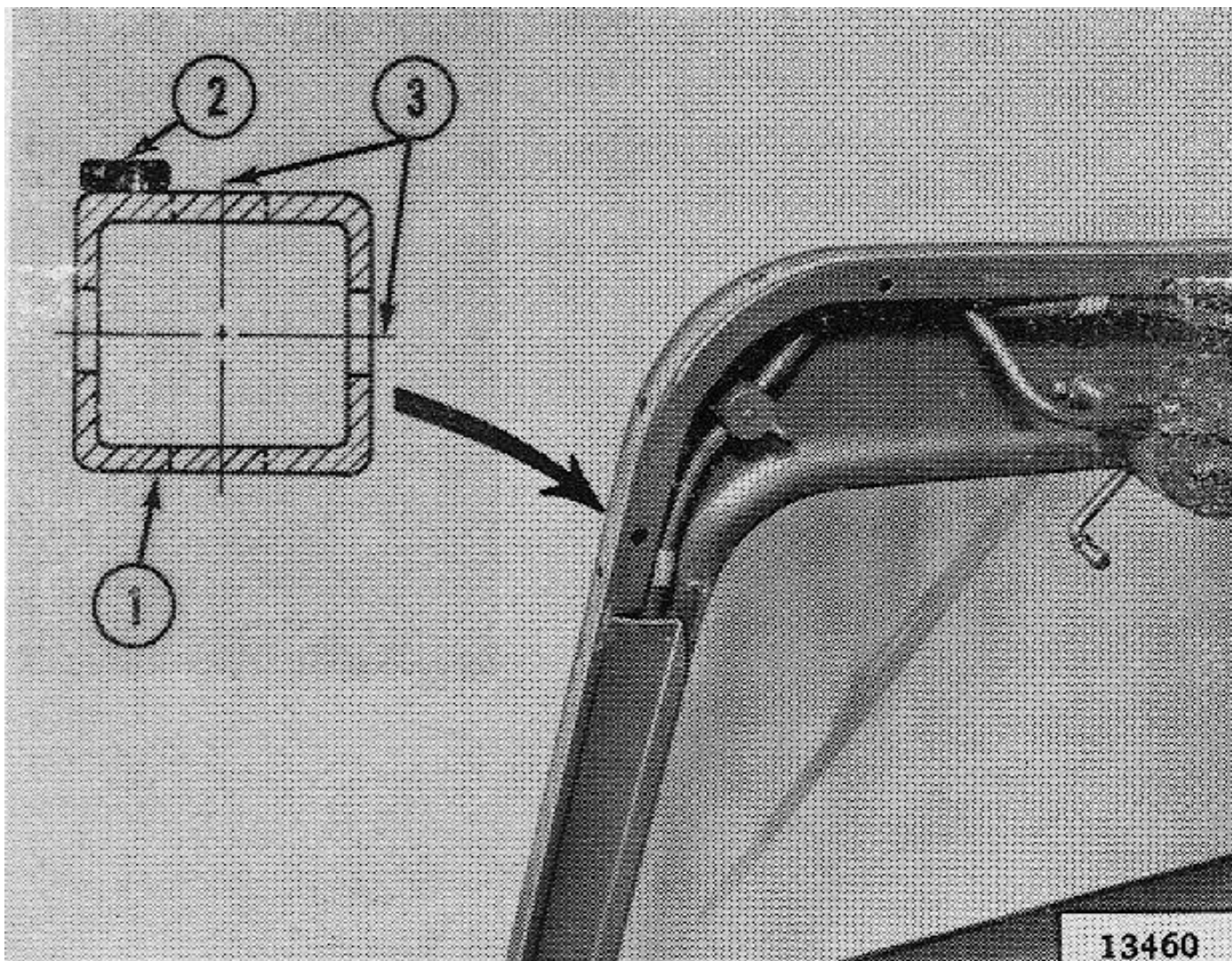

FIG. 33-A5 WINDSHIELD FRAME PREPARATION

- 1 Windshield Frame
- 2 Sealant (Front Edge)
- 3 Drill Through Frame

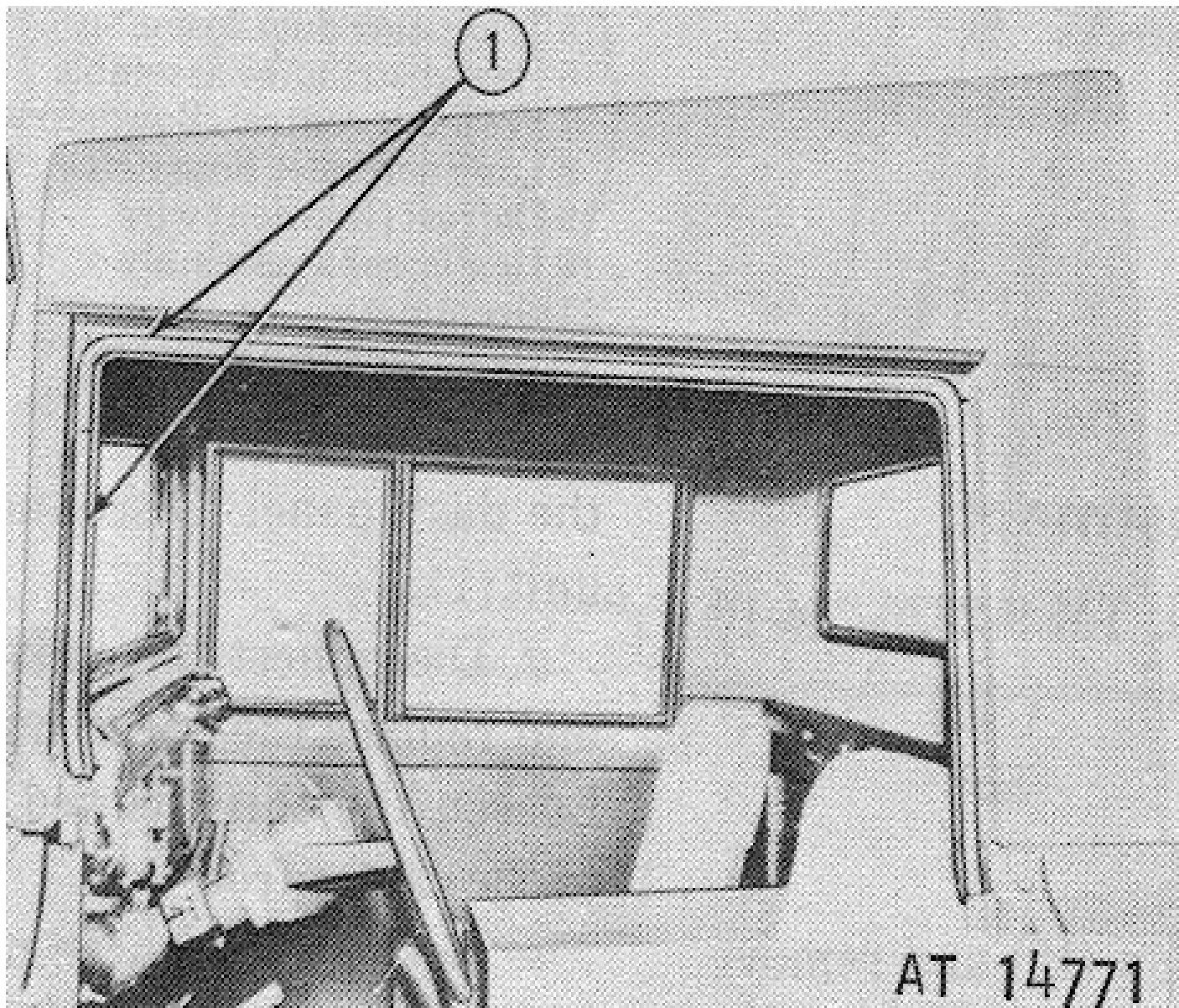

FIG. 33-A6 WEATHERSEAL INSTALLATION

1 Weatherseal

33-A8. MODIFICATION AND INSTALLATION PROCEDURE

- Clean and inspect the vehicle body surfaces that will mate with the Arctic Enclosure Kit. These include the body back panel flange and the windshield.
- Place the back panel assembly on the body back panel, making sure it is in the proper mounting position; lower edges of panel square with the vehicle and clearing upper rear corner of door.
- Use the seven holes located on the lower mounting flange of the back panel as a template and center punch the holes to be drilled in the body back panel reinforcement. Remove back panel from the vehicle.

- d. Drill seven (7) 7/16" diameter holes in the body back panel reinforcement.

Note: The seven (7) holes receive Jack Nuts and are drilled through one thickness of metal only. Do not drill clear through the rear body panel.

- e. Install the seven (7) Jack Nuts, using a Jack Nut Installation Wrench (Fig. 33-A3).
- f. Apply a bead of sealant on the body back panel (back and sides) (Fig. 33-A3).
- g. Reinstall back panel on body back panel and secure with seven (7) 1/4-20x1 Hex Head Cap Screws to the Jack Nuts. Do not over-torque. (Refer to Fig. 33-A4).
- h. Using the holes in the sides of the back panel as a template, drill four (4) %2 diameter holes through the body side panel flanges. Secure with four (4) 1/4-20x1/2 Truss Head Machine Screws and locknuts.
- i. Position roof panel assembly on back panel and windshield frame, aligning holes in the back panel upper flange with the holes in the roof rear flange. Center punch fifteen (15) holes to be drilled through the windshield frame. Remove roof assembly.
- j. Drill fifteen (15) %2 diameter holes through the windshield frame where marked. Apply bead sealant to front edge of windshield frame mating surface (Fig. 33-A5).
- k. Apply bead sealant to upper flange of back panel.
- l. Reinstall roof panel and secure with nine (9) 1/4-20x1 3/4 Truss Head Machine Screws (front) and six (6) 1/4-20x1 1/4 Truss Head Machine Screws (side) and locknuts. Use thirteen (13) 1/4-20x1/2 Hex Head Cap Screws, washers and locknuts, to secure roof panel to back panel. Plug two existing holes at upper ends of windshield with 1/4-20x1 3/4 Truss Head Machine Screws and locknuts.
- m. Install the two pieces of weatherseal at each door frame opening by pressing into place over the metal flanges (Fig. 33-A6). Windshield seal (shortest piece) should be installed first. Start with lower end at bottom of retainer flange on windshield, butt second piece to first following flange on door window opening. At lower end, joggle weatherseal and attach to flange on body back pillar.
- n. Adjust door glass and/or sealing flange as required to obtain seal between window frame and weatherseal. Apply sealer to all gaps in sheet metal joints.

33-A9. REMOVAL PROCEDURE

- a. Remove weatherseal from cab door frame opening.
- b. Remove roof assembly attaching screws front and rear.
- c. Remove roof assembly.
- d. Remove the four (4) attaching screws from the sides of the back panel. Remove the seven (7) attaching screws from the Jack Nuts on the lower flange of the back panel. Remove the back panel.
- e. Remove sealant from all mating surfaces.
- f. Clean all parts of the kit assembly and store.

33-A10. PREVENTIVE MAINTENANCE

- a. Inspect all bolts, nuts, and screws for security of attachment.
- b. Examine metal panels for signs of corrosion or fatigue at joints and attaching holes. Clean corrosion at joints and attaching holes. Paint with primer followed by finish coat.
- c. Inspect window glass for broken or chipped areas which interfere with vision or safety. Replace glass if necessary.
- d. Inspect weatherseal for hardening or loss of sealing properties. Replace if necessary.
- e. Inspect any insulating material for security of adhesion to panels. Reseal if necessary.

33-A11. TESTING

To test the joints and weatherseals of the Arctic Enclosure Kit, proceed as follows:

- a. Roll up the cab door windows and close the doors securely.
- b. Using a 6 inch stream of water from a small hose, proceed around the Arctic Enclosure Kit, splashing the water over all seams and weather-seals.

- c. Allow excess water to drain off and open the doors and inspect the cab interior for leaks.
- d. Tighten or reseal all seams that admit water.
- e. Adjust or replace weatherseals.

An alternate method to check for leaks is with the powder test. Puff the powder spray around seams and seals. Open the doors and look for powder traces on the weatherseals. If there is a leak, the powder will leave a trace through the loose seal.

33-A12. TROUBLESHOOTING

Malfunction	Probable Cause	Corrective Action
Door not latching	Roof assembly mounted incorrectly	Remount roof
Rattles	Loose joints	Tighten bolts
Excessive air leaks	a. Loose joints	a. Tighten bolts
	b. Weatherseal worn	b. Replace
Water leaks	a. Loose joints	a. Tighten bolts
	b. Weatherseal worn	b. Replace

Section VI. FRESH AIR HEATER AND DEFROSTER KIT

33-F1. PERSONNEL HEATER KIT (25 Degrees F.)

33-F2. DESCRIPTION

The Personnel Heater Kit (25°F.) uses a single-speed, 24-volt fan motor to circulate heated air to the crew compartment. Outside air is drawn into the fan and blown out across the heater assembly where it is heated by circulating coolant from the engine. The heated air enters the vehicle through the transition duct into the heat distributor where it is distributed to the defroster nozzles or floor. Controls of the heater are grouped on the instrument panel and afford simple operation. (Refer to Fig. 33-F1).

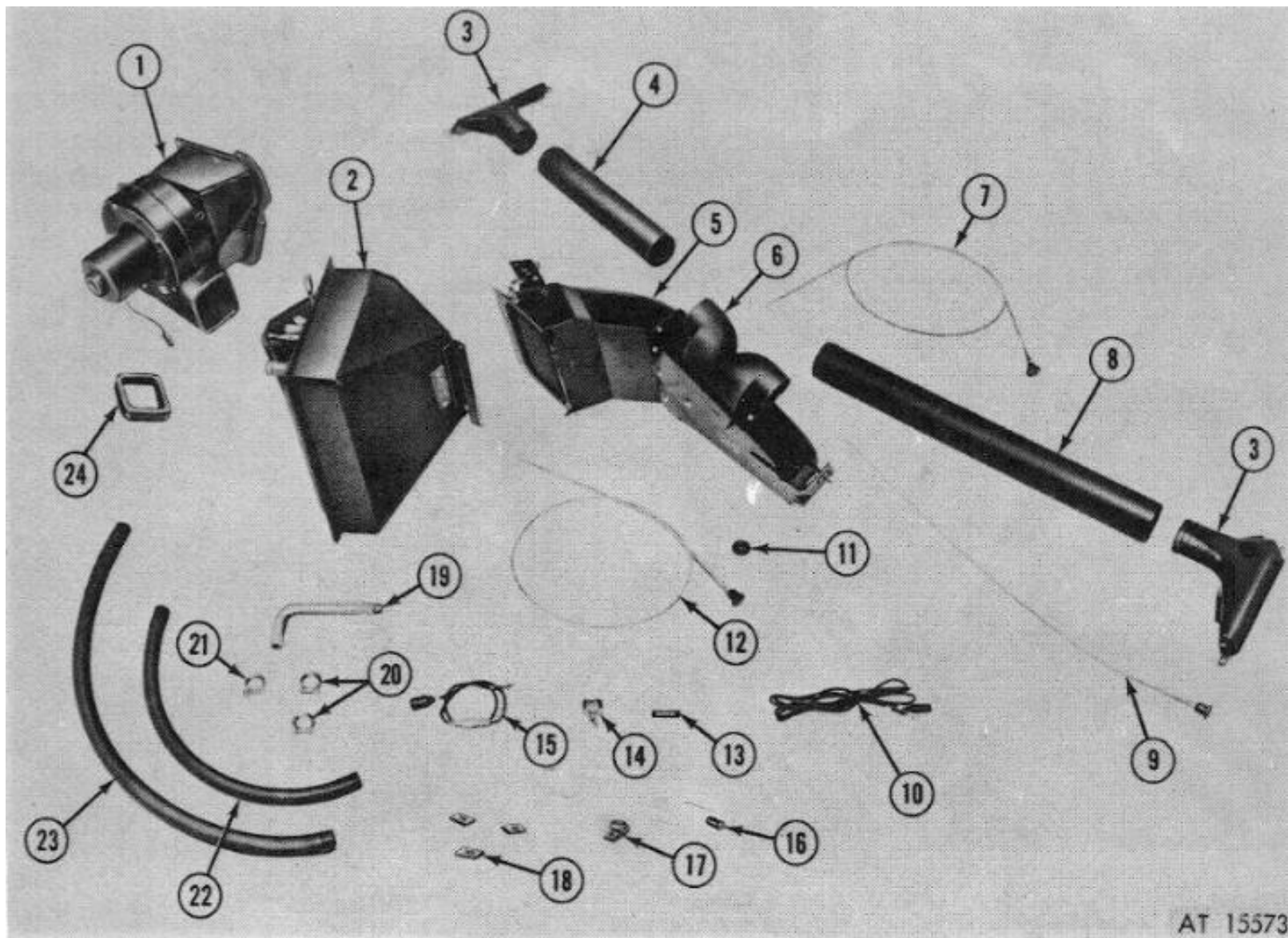
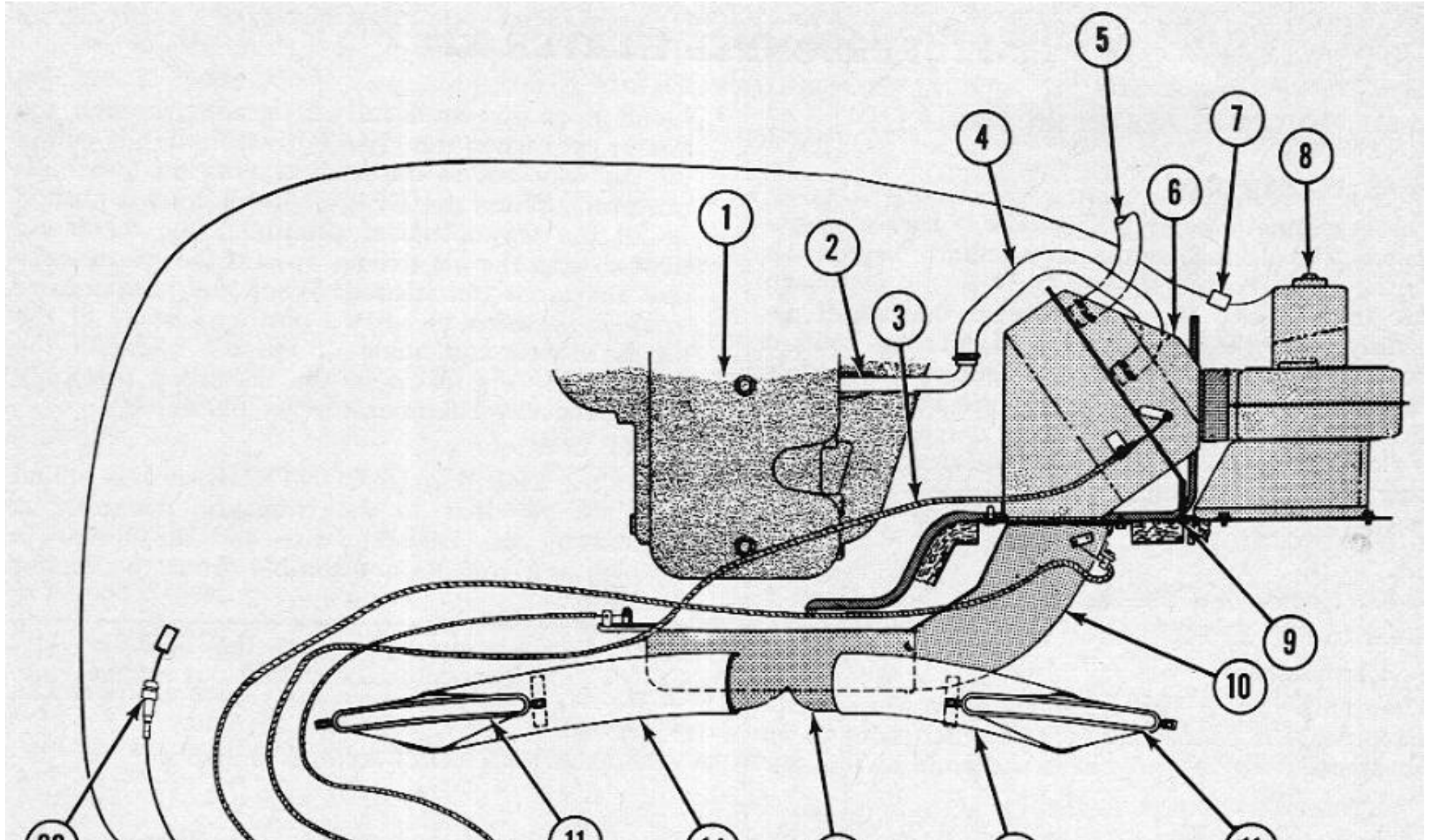

FIGURE 33-F1-Personnel Heater Kit (-25 F)

1 Blower and air inlet assembly	7 Fresh air control (Bowden) wire	13 Decal	19 90 degree tube
2 Heater assembly	8 Long defroster hose (left)	14 Blower switch	20 15/16 inch clamp
3 Nozzle (defroster)	9 Defrost (Bowden) wire	15 Fused heater cable	21 1 inch clamp
4 Short defroster hose (right)	10 Heater cable assembly	16 Spacer	22 Short hose
5 Transition duct assembly	11 Grommet	17 Closed clip	23 Long hose
6 Heat distribution assembly	12 Heat (Bowden) wire	18 Speed nut	24 Rubber seal

NOTE: The following parts are included in the Personnel Heater Kit (-25 Degrees) (not shown):

1. Permagum Sealant
9. 1/4 -20 Hex Machine Screw Nut
9. 1/4-20 Lock Washer
8. 8 -15x 3/8 Hex Washer Head Tapping Screws
1. 3/4 -14x 1 1/4 Hex Tapping Screw
1. Plain Washer
3. 3/8-24 Hex Nut
3. 3/8-24 Lock Washer
1. 1/4-20x 1/2 Hex Bolt



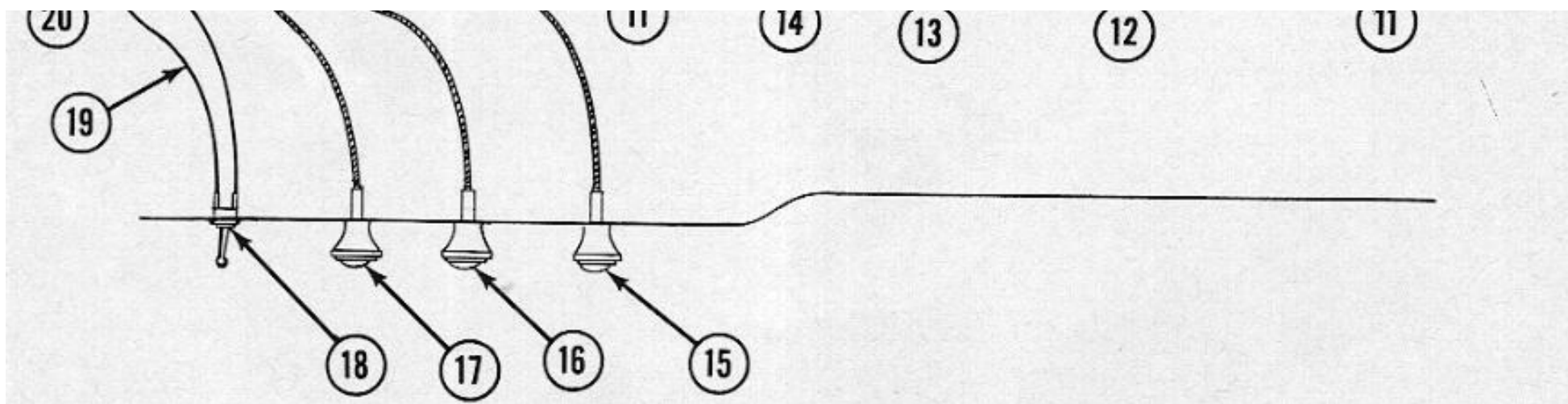

FIGURE 33-F2-Heater and Defroster, Top View

1 Engine	6 Heater Assembly	11 Defroster Nozzle	16 Heat Control Knob
2 90° Tube	7 Waterproof Connector	12 Short Defroster Hose (Right)	17 Fresh Air Control Knob
3 Heat Control Bowden Wire	8 Blower and Air Inlet Assembly	13 Heat Distributor Assembly	18 Heater Switch
4 Short Hose	9 Firewall	14 Long Defroster Hose (Left)	19 Heater Cable Assembly
5 3/2 Inch Hose	10 Transition Duct Assembly	15 Defrost Control Knob	20 Fused Battery Cable

33-F3. Heater and Defroster Control Operation

Refer to Fig. 33-F2.

a. Temperature

The temperature (HEAT) knob on the instrument panel is connected by a Bowden wire to an air blend door in the heater assembly. The air blend door directs a full air stream through the heater core when the HEAT control knob is pulled all the way out to its extreme position (warmest position). When the HEAT control knob is pushed in all the way (coolest position), the air blend door directs the air stream around the heater core and the air is not heated. When the temperature knob is between these two positions, some of the air is heated and some of the air bypasses the heater. The air mixes in the transition assembly and the desired temperature is obtained.

b. Air Control

When the FRESH AIR CONTROL knob is pulled out, the air door in the transition assembly is opened by the Bowden wire and air comes in through the transition assembly from the heater assembly.

Note: For maximum heating, the FRESH AIR CONTROL knob must be pulled out all the way.

c. Defroster

When the DEFROST knob is pulled out, the distributor assembly air baffle is opened and air is directed to the windshield via hoses and nozzles.

d. Heater Switch

The heater switch is a two-position toggle switch. The OFF position is down and the ON position, up. The instrument panel marking denotes switch operation (BLOWER).

33-F4. VEHICLE MODIFICATIONS

Minor vehicle modifications described in Par. 33-F7 are necessary to install the heater assembly and controls.

33-F5. Drawings Required

None required.

33-F6. Special Jigs, Fixtures, and Tools Required

None required.

33-F7. Disposal of Discarded Parts

Discarded parts will be disposed of in accordance with AR 755-6 and AR 755-10.

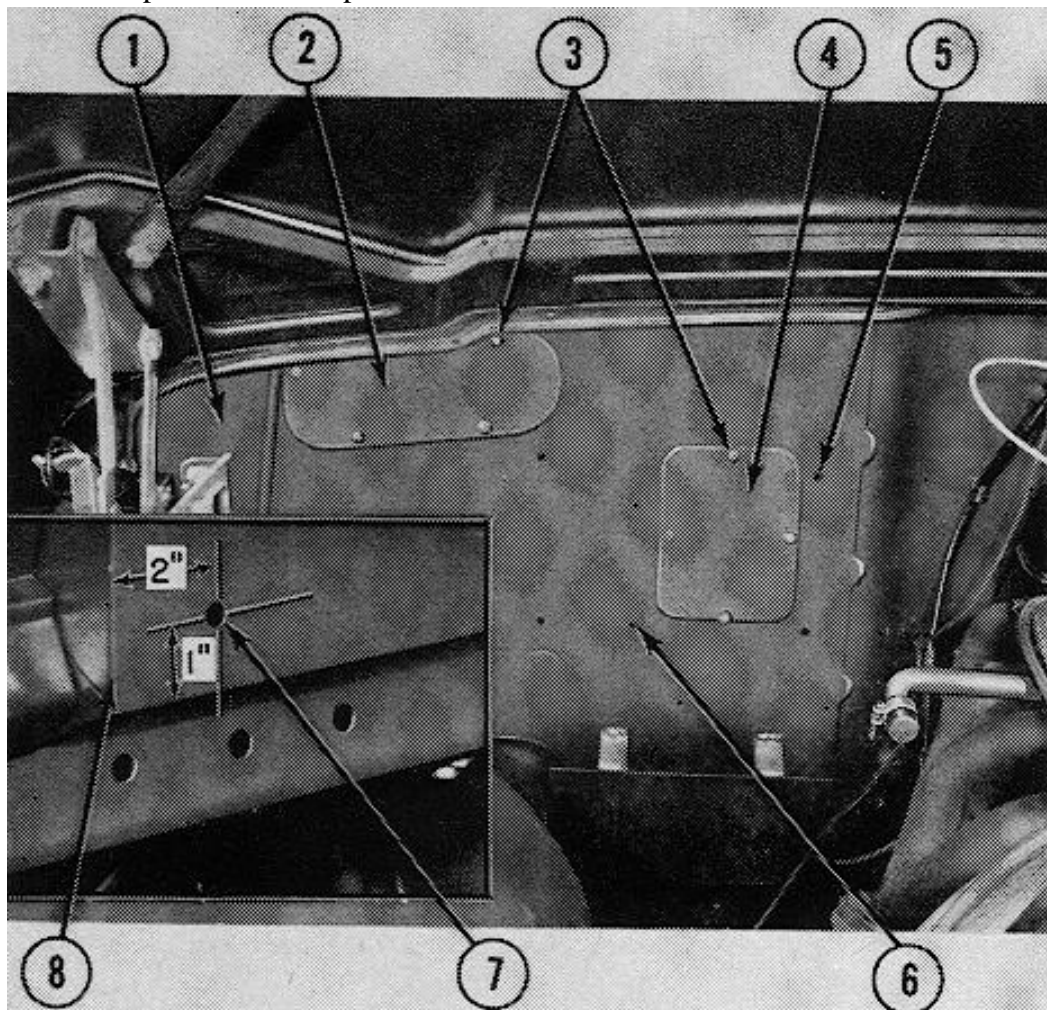

FIG. 33-F3 MODIFICATIONS FOR HEATER KIT INSTALLATION

1 Firewall

2 Upper Cover Plate

3 Self Tapping Screw (14-14 x ½)

4 Lower Cover Plate

- 5 Button Plug
- 6 Plug Screw
- 7 1/2 Inch Hole (Drill)
- 8 Instrument Panel

33-F8. MODIFICATION PROCEDURE

a. Remove the four tapping screws and lock washers from each of the dash panel cover plates (upper and lower) on the right side of the dash panel in the engine compartment.

Remove and stow cover plates. (Refer to Fig. 33-F3.)

b. Drill 1/2 inch dia. hole in instrument panel for BLOWER switch. (Refer to Fig. 33-F3.)

c. Remove four button plugs from heater mounting holes on engine side of dash panel.

d. Remove five tapping screws (plugs for blower assembly and transition duct mounting holes).

e. Remove glove box.

f. Drain coolant from engine.

g. Remove short pipe plug between the fourth and fifth outlet ports of the exhaust manifold.

h. Install the 90° tube in cylinder head with short end facing forward.

i. Remove clamp and rubber cap from water pump inlet collar. Retain the clamp.

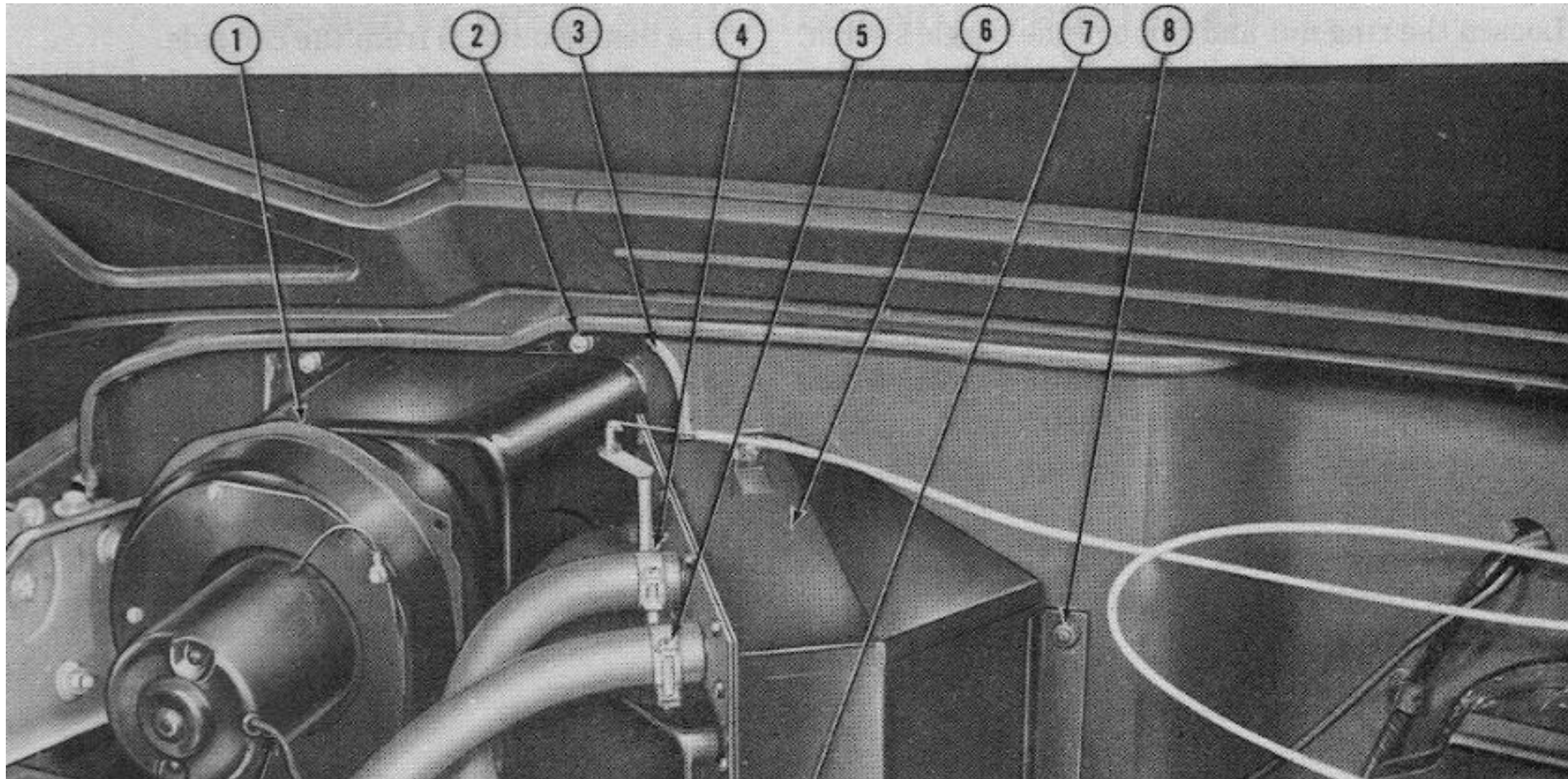

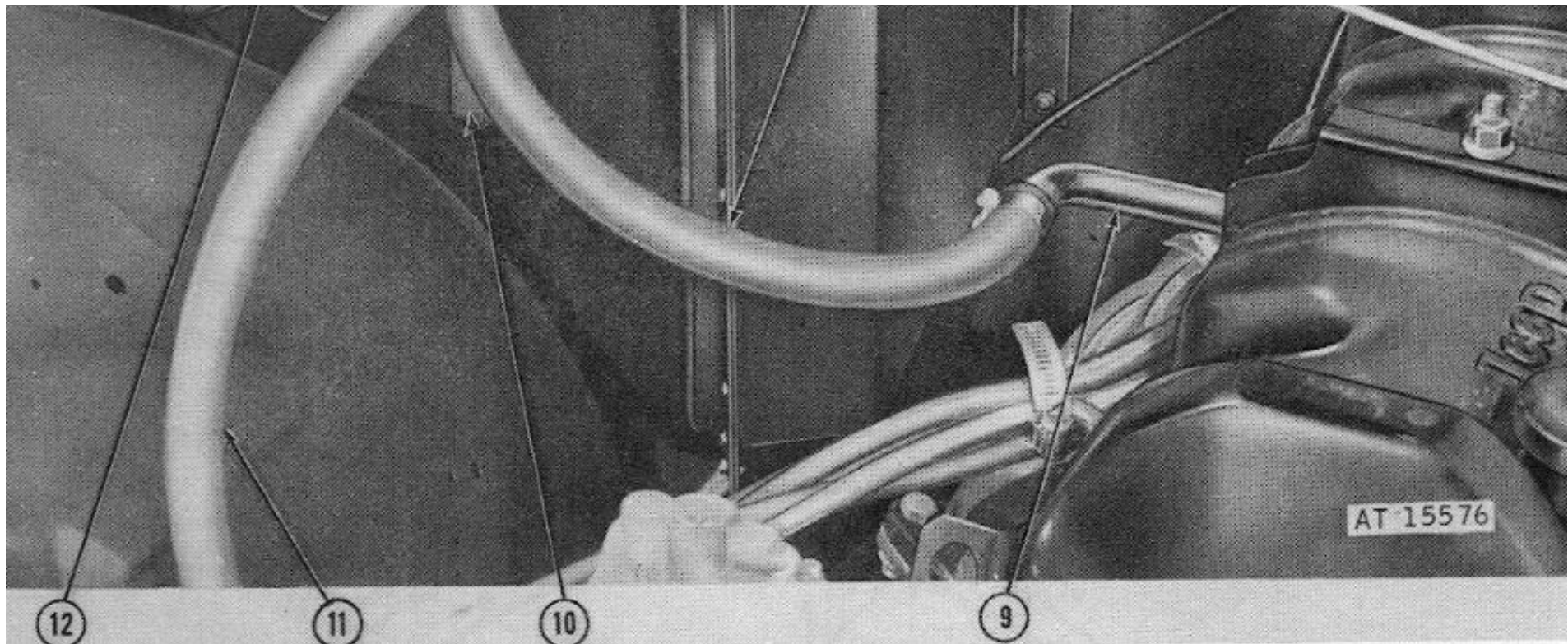

FIGURE 33-F4-Personnel Heater Installation

1 Blower and air inlet assembly	5 1 inch clamp	9 90 degree tube
2 Screw and lockwasher	6 Heater assembly	10 Rubber seal
3 Permagum sealant	7 Short hose	11 Long hose (to water pump)
4 Clamp	8 1/4-20 hex nut and lock washer assembly	12 Heater cable assembly

33-F9. HEATER INSTALLATION

33-F10. Kit Installation Engine Compartment

- Position heater core assembly on dash panel over the lower hole from which cover plate was removed. The two studs on the right flange of the heater core extend through the two holes on the dash panel from which plugs were removed.
- By bracing or soliciting help from other personnel, hold the heater assembly in place on the dash panel.
- Secure with two 1/4-20 Hex Machine Screw Nuts and lock washers on the studs inside the cab.
- Place a bead of sealant around the mating flange of the blower intake mount and install the rubber seal at the outlet opening.
- Position the blower assembly on the dash panel over the upper hole from which the cover plate was removed. Mate the blower outlet seal to the heater core intake opening.
- Secure to dash panel with four 14-14x1/2 Tapping screws and lock washers previously removed.

33-F 11. Coolant Hose Connections

- Place the 1 inch minimal dia. hose clamp (No. 8) on one end of the long hose and the previously removed clamp on the other end.

- b. Attach the hose and No. 8 clamp to the forward collar of the heater assembly. Attach the other end to the water pump inlet collar. Position and tighten the clamps.
- c. Place the two 3/8 inch minimal dia. clamps (No. 7) on the ends of the short hose. Attach the ends to the right angle tube and rearward collar of the heater assembly. Position and tighten clamps.

33-F 12. Heat Distributor and Transition Duct Installation

- a. Assemble the heat distributor assembly and transition duct assembly together using eight 8-15x3/8 Hex Washer Head Tapping screws.
- b. Position the assembly on the inside of the dash panel over the lower heater hole, extending the two studs on the left mounting flange through the dash panel holes from which two plugs were removed and left flange of the heater assembly.
- c. Secure the right transition duct assembly flange to the inside of the dash panel with two previously removed lower cover screws. The mounting dash panel holes were previously plugged with two screws.
- d. Secure the left mounting flange of the heat distributor assembly to the dash panel using the 1/4-14x1 1/4 Hex Head Tapping screw, plain washer, and spacer.
- e. Tighten the heat distributor and transition duct assembly mounting screws.
- f. From the engine compartment side, install and tighten two 1/4-20 Hex Head Machine Screw Nuts and lock washers on the studs extending through the left heater assembly mounting flange.
- g. Position the two defroster nozzles on the mounting studs under the openings of the cowl on either side of the windshield with the inlets towards the left of the cab.
- h. Secure with two each 10-24 Hex Nuts and lock washers. (Refer to Fig. 33-F5.)
- i. Install the long defroster hose on the left nozzle and heat distributor outlet and the short hose on the right nozzle and outlet.
- j. Reinstall previously removed glove box.

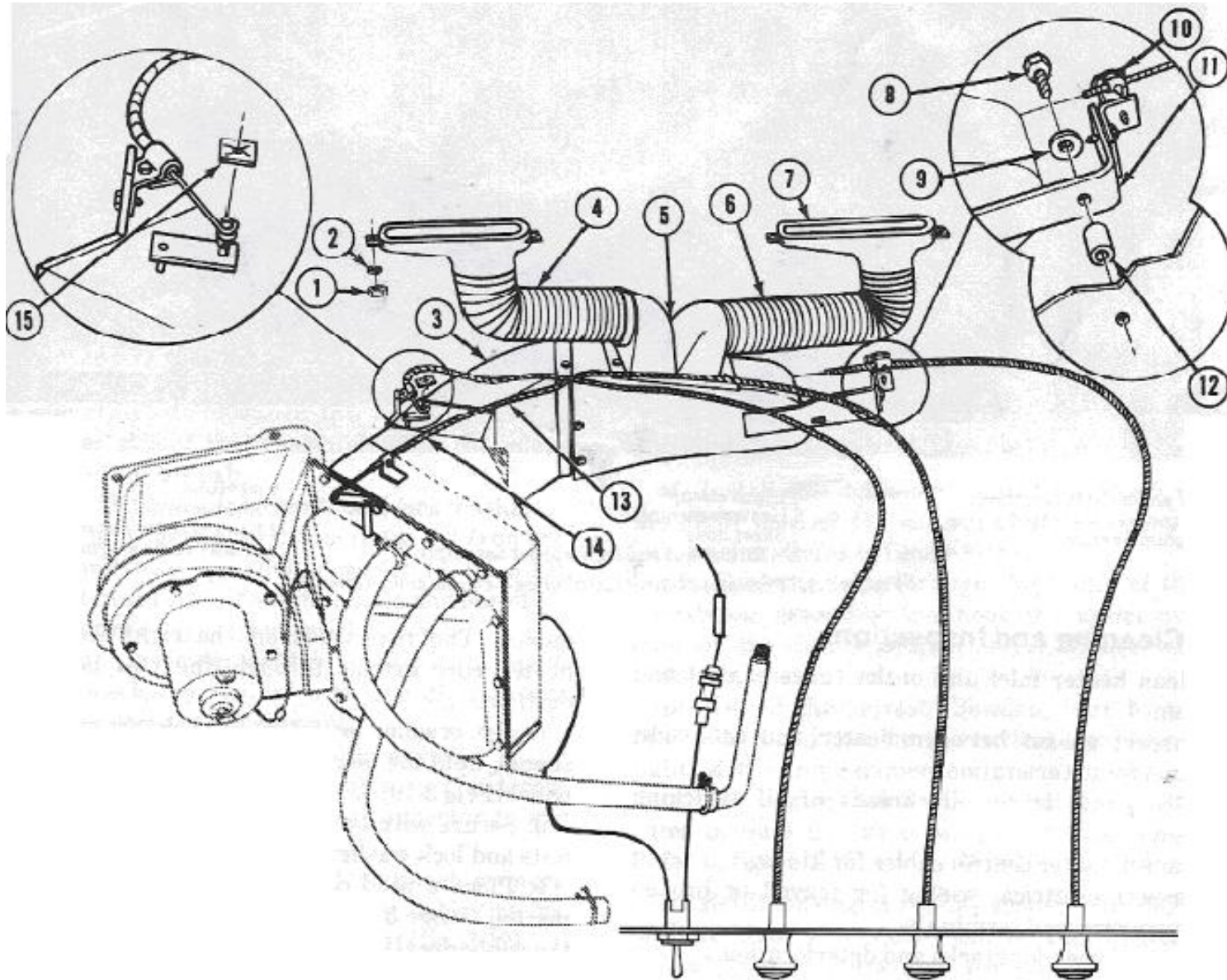

FIGURE 33-F5-Fresh Air Heater and Defroster, Front View

1 10-24 hex machine screw nut	5 Heat distributor assembly	9 Plain washer	13 Heat control (Bowden) wire
2 Lock washer	6 Long defroster hose	10 Screw cable retainer	14 Air control (Bowden) wire
3 Transition duct assembly	7 Nozzle	11 Bracket defroster cable mounting	15 Speed nut

4 Short defroster hose	8 1/4-14 x 1 1/4-inch hex head tapping screw	12 Spacer	
------------------------	--	-----------	--

33-F 13. Heater Controls Installation

- Position the heater switch in the instrument panel hole previously drilled with the OFF position downward and secure with ring nut.
- Attach the BLOWER decal above the switch. (Refer to Fig. 33-F6.)
- Attach the fused battery cable to the lower switch terminal and the waterproof connector to the wire harness connector (Circuit #85).

Note: Remove the fuse for this operation.

- From the engine side of the dash panel, connect the waterproof connector of the heater cable assembly to the connector on the blower motor.
- Route wire under heater core assembly and up through existing wire harness clips on dash.
- Feed the terminal end of the heater cable through the harness grommet located above and to the right of the engine centerline.
- From the cab side, pull the cable through the dash panel and connect to the upper terminal of the heater switch.
- Install the fuse in the battery cable and test fan operation by turning switch on.

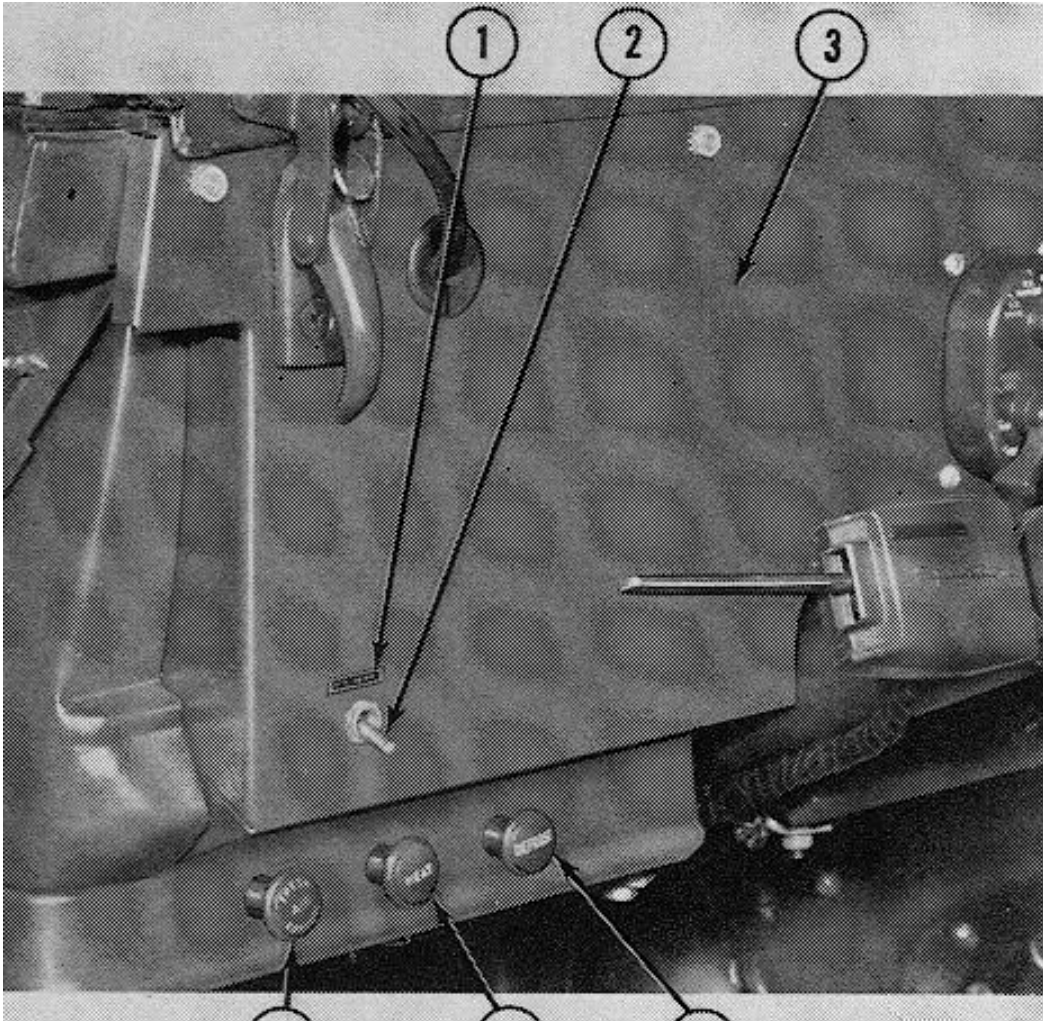

6

5

4

FIG. 33-F6 HEATER CONTROLS INSTRUMENT PANEL

- 1 Decal
- 2 Heater Switch
- 3 Instrument Panel
- 4 Defroster Control Knob
- 5 Heat Control Knob
- 6 Air Control Knob

33-F14. Air Control Assembly Installation

- a. Install the FRESH AIR CONTROL Bowden wire knob in the left hole of the heater control cluster using a 3/8-24 nut and lock washer.
- b. Position the closed clamp on the wire and secure to the instrument panel lower reinforcing flange existing hole near the center using 1/4-20x1/2 Hex Head Bolt, nut, and lock washer.
- c. Feed the Bowden wire through the clamp of the transition duct and hook the eyelet over the door lever stud. Secure the eyelet on the stud with the speed nut.
- d. Adjust the wire by pushing the knob in and closing the air door lever towards the dash panel (forward). Tighten the clamp.

33-F 15. Heat Control Assembly Installation

- a. Install the heat control Bowden wire in the center hole of the control cluster using 3/8-24 nut and lock washer.
- b. Remove and discard the grommet holding the engine choke Bowden wire to the dash panel.
- c. Feed the heat wire through the dash panel beside the engine choke wire.
- d. Replace the grommet with the one furnished with the kit, securing both Bowden wires to the dash panel.
- e. Feed the heat wire through the heater assembly clamp and slip the eyelet over the stud of the heat control lever. Secure with the speed nut.
- f. Adjust the heat control Bowden wire by pushing the knob in and moving the control door lever towards the right side of the compartment. Tighten the wire clamp.

33-F16. Defroster Control Assembly Installation

- a. Install the defroster control Bowden wire in the right hole of the control cluster using 3/8-24 nut and lock washer.
 - b. Feed the wire through the clamp of the heat distributor assembly and hook the eyelet over the stud of the defroster door lever. Secure with the speed nut.
 - c. Adjust the DEFROST Bowden wire by pushing the knob in and moving the control lever toward the right of the compartment. Tighten the wire clamp.
- Test the heater controls making sure Bowden wires operate the air doors properly and smoothly.

33-F17. Final Operations

Refill the engine cooling system with the proper coolant. Start the engine and let the coolant warm up to normal operating temperature. If there is evidence that the cooling system is air locked, remove forward hose on heater core to bleed air from system. Check all hose connections for leaks. Check heater operation by testing air temperature with knobs in different positions. Shut off engine and correct any faults.

33-F18. KIT REMOVAL

- a. Drain the cooling system.
- b. Disconnect the fuse connection and remove the wire at the toggle switch.
- c. Disconnect the heater cable harness from the toggle switch and pull it through the grommet on the dash panel. Disconnect at the side of the heater unit.
- d. Disconnect the ends of the three Bowden wires and replace the speed nut fasteners on the studs. Loosen the three clamp fasteners and pull the ends of the cables free.

- e. Remove the three nuts and lock washers securing the control knobs from the dash and remove the cables. Replace the lock washers and nuts on the cable knobs.
- f. Loosen the ring nut and remove the toggle switch.
- g. Remove the two defroster hoses.
- h. Remove the glove box.
- i. Disconnect the two nuts and lock washers on each of the two defroster nozzles and remove.
- j. Replace the glove box.
- k. Remove the two water hoses connecting the heater unit with the cylinder head and the bypass on the water pump.
- l. Remove the 90° tube from the cylinder head and replace with the original short straight pipe and cap. Cap the water pump bypass hose. Tighten the clamp.
- m. Remove the four mounting screws from the fan motor and replace the upper cover with the removed screws.
- n. Remove the two right hand mounting nuts for the heater unit from the cab side.
- o. Remove the left two mounting nuts from the engine side and remove the heater unit.
- p. Remove the self tapping screw, spacer, and washer from the diverter box mounting flange. Remove the assembly.
- q. Remove the two screws securing the right flange of the diverter box. Remove the assembly.
- r. Replace the lower dash panel cover plate using the two previously removed screws and the two screws holding the diverter box from the inside.
- s. Remove the eight screws and separate the transition duct and the diverter box assembly.
- t. Refill the cooling system.

33-F19. PREVENTIVE MAINTENANCE

Very little preventive maintenance is required. Seasonal inspection of hoses, wiring and defroster tubes should be made. A few drops of oil should be used on the Bowden cables for easy operation.

33-F20. TESTING

Start the vehicle engine and run at fast idle until normal operating temperature is obtained. Turn the heater switch to the ON position. The heater motor should start immediately and hot air should be expelled from the heater. If poor or no heat is felt the probable causes are: blower inoperative, heater hoses kinked or deteriorated and/or heater core plugged or air bound.

A check of the blower system can be made by listening to ascertain if the blower motor is running and holding the hand over the air outlet of the heater. If the motor is not running, check for burned out fuse and clean and tighten the ground lead connection. If it is determined that current is reaching the motor and that the ground is clean and tight, the probable cause is in the motor and it should be repaired or replaced. If the motor can be heard running and no air is being blown from the air outlet of the heater, the blower assembly must be removed and the probable cause will be a loose blower fan on the motor shaft. If the blower system is operating properly but cold air is blown from the heater, first determine the condition of the heater coolant hoses. If found to be badly kinked or deteriorated replace the hose(s).

Note: The heater coolant hoses may have been connected to the heater wrong. The hose from the rear of the engine block should be connected to the rearward heater core pipe and the hose from the water pump housing tube be connected to the forward heater core pipe.

If coolant hoses are connected properly and the block to heater hose is warm, and the heater to water pump housing hose is cold, the probable cause is a clogged heater core or air bound core. The heater core may be tested by removing the two hoses from the core pipes and, using an outside source of water, flush the heater core by attaching the water source to the rearward heater pipe and noticing the flow from the forward core pipe. The flow should be free and clean. If core is found to be plugged or water is extremely dirty the core must be removed and cleaned or replaced. If the heater works satisfactorily and there is insufficient or no defrosting hot air at the defroster nozzles, the probable causes are improper defroster control cable adjustment or disconnected defroster hose(s). Inspect installation of the defroster hoses and their condition, replace any defective or damaged hose(s). Properly adjust the control cable and using an oil can and light engine oil, lubricate the control cables and door valve shafts. Inspect the heater core and hose connection for coolant leaks. Repair as necessary.

33-F21. TROUBLESHOOTING

Malfunction	Probable Cause	Corrective Action
1. Cool or cold air at heater outlet after engine has reached normal operating temperature	a. Soft or collapsed hot water hose(s)	a. Inspect water hoses. Replace all soft or damaged hoses.
	b. Air in heater (air bound)	b. Disconnect top heater hose and bleed all air from heater core. Check coolant level in radiator.
	c. Heater hoses connected to heater wrong	c. Check hose for proper installation. Reverse hoses if installed wrong.
	d. Plugged heater core	d. Replace heater core.
2. Cool or cold air at heater outlet due to coolant temperature	a. Defective engine thermostat	a. Replace engine thermostat.
	b. Extreme cold weather	b. Install or adjust brush guard cover.
3. No air flow at defroster	a. Flexible defroster hose(s) disconnected at nozzle or diverter box	a. Check flexible defroster hose(s) making sure they are properly connected.
	b. Collapsed or damaged defroster hose(s)	b. Replace damaged defroster hose(s).
	c. Bowden cable not properly adjusted to transition duct door	c. Readjust Bowden cable to duct door lever and secure.
	d. Leaky windshield to body seal	d. Reseal windshield to body.
4. No air flow at driver s heat outlet	a. Hose disconnected at diverter box	a. Connect hose to diverter box.
	b. Collapsed or damaged hose	b. Replace hose.
	c. Transition duct door not properly adjusted to Bowden cable.	c. Readjust Bowden cable to duct door lever and secure.
5. Blower motor inoperative	a. Lead to heater switch broken or disconnected	a. Repair or replace broken wire. Inspect wire connections. Clean and tighten connections as necessary.
	b. Fuse blown	b. Replace fuse.
	c. Heater electric open circuit	c. Check heater wiring for open circuit. Repair or replace wire(s) as necessary.
	d. Defective blower motor	d. Replace blower motor.
	e. Defective switch or circuit breaker	e. Replace defective or burned out parts.
6. No input when service cable is connected	a. Heater not properly grounded	a. Check heater and heater motor for proper ground. Securely ground heater and blower motor.
	b. Input service cable not properly connected	b. Check service cable for cleantight connections

7. Control cable(s) stick or do not move	a. Control cable(s) kinked or rusted	a. If rusted badly or kinked replace cable(s). Slightly rusted cable(s) may be cleaned and oiled with penetrating oil.
	b. Cable(s) not properly adjusted	b. Adjust all cables as necessary. Tighten cables securely. Use penetrating oil to free sticking or binding cables.

CHAPTER 4

ADMINISTRATIVE STORAGE

4-1. General.

Commanders are responsible for insuring that all vehicles issued or assigned to their command are maintained in a serviceable condition and properly cared for, and that personnel under their command comply with technical instructions. Lack of time, lack of trained personnel, or lack of proper tools may result in a unit being incapable of performing maintenance for which it is responsible. In such cases, unit commanders may, with the approval of major commanders, place vehicles that are beyond the maintenance capability of the unit in administrative storage or return it to supply agencies. When preparing vehicles for administrative storage or for shipment, the unit commander will be responsible for processing the vehicle, including all tools and equipment, in such a manner as to protect it from corrosion, deterioration and physical damage. Refer to TM 38-230-1 for general administrative storage procedures.

4-2. Administrative Storage Instructions.

a. Time Limitations. Administrative storage is restricted to a period of 90 days and must not be extended unless the vehicle is reprocessed in accordance with b below.

b. Storage Procedure. Disassembly will be limited to that necessary to clean and preserve exposed surfaces. The vehicle will be placed in administrative storage in as nearly a completely assembled condition as practicable. Equipment will be installed and adjustments made so that the vehicle may be placed in service and operated with a minimum of delay.

(1) Perform an S semi-annual preventive maintenance service on vehicles intended for administrative service. This maintenance will consist of inspecting, cleaning, servicing, preserving, lubricating, adjusting and replacement of minor repair parts.

(2) Fill fuel tank completely full.

(3) Remove storage batteries and place in covered storage, maintaining a charged condition.

(4) Provide access to the vehicle to permit inspection, servicing and subsequent removal from storage.

(5) Mark the vehicle Administrative Storage on windshield; tagged, or other convenient method. Vehicles so marked will not be operated while in this category.

c. Inspection in Administrative Storage. Visual inspections of vehicles in administrative storage will be conducted in accordance with procedures contained in TM 38-230-1. A record of these inspections will be maintained for each vehicle in administrative storage, attached to the vehicle in such a manner as to protect the record from the elements.

d. Deprocessing at Domestic Shipment Destination for Service

(1) The deprocessing required before operation will appear opposite the processing accomplished. Use DD Form 1397 (Processing and Deprocessing Record for Shipment, Storage and Issue of Vehicles and Spare Engines).

a. Removal of Sealing and Preserving Materials.

(1) Remove all sealing and protective materials that have been applied.

- (2) Remove preservatives, as necessary, with approved cleaning solvents, and service as instructed in pertinent technical manuals.
- (3) Unblock the clutch.
 - b. Installation of Components and Equipment Removed. Install all removed components and equipment in normal operating position.
 - c. Tires. Inflate to prescribed pressure.
 - d. Spare Fuel Container. Flush thoroughly with approved solvents and install on vehicle.
 - e. Drains, Inspection Plates, and Valves. Close drains, remove screens, and install inspection plates and gaskets.
 - f. Lubrication.
 - (1) Refer to sample record to assure that oils applied are applicable for operation within the current local temperature range. Unsuitable oils will be drained and replaced with proper grade oils.
 - (2) Preservative oils in lubrication systems as indicated will be kept to operating level until first oil change.
 - (3) Refer to LO 9-2320-244-12, and lubricate (oil or grease) all points regardless of interval since last lubrication.
Exception: Wheel bearings and those items indicated on form.
 - g. Batteries. Change, service, or install as necessary, clean posts, and connect.
 - h. Belts (Fan, Alternator etc). Tighten to proper tension.
 - i. Engines.
 - (1) Gasoline engines not reprocessed within the period established in TB 9 300 2/ 1, indicated in Reprocessing Cycle block on face of form, shall be serviced before use, as follows:
 - (a) Remove spark plug from each cylinder.
 - (b) Atomize spray 2 ounces of lubricating oil preservative special, into each cylinder through the spark plug opening.
 - (c) After an interval of 15 minutes rotate engine with starter for 30 seconds.
 - (d) Reinstall spark plugs.
 - (e) See TB ORD 392.
 - (2) Refer to TM 9 2320 244 10. Caution must be used in starting the engine to insure that malfunctions such as hydrostatic lock do not occur.
- e. Deprocessing at Oversea Shipment Destination for Service
 - (1) In order that materiel will not be damaged due to corrosion during initial operation, thoroughly flush all surfaces that have been exposed to salt water with fresh water as soon as practicable. In addition, disassemble, clean, and lubricate essential operating mechanisms, in accordance with LO 9-2320-244-12, as soon as the tactical or logistical situation permits.
 - (2) Perform any of the deprocessing prescribed in paragraph 22-29a through i, that is applicable.
- f. Deprocessing in Storage Prior to Operation
 - (1) General. Perform any of the deprocessing prescribed in paragraph 22 29 (a through i) that is applicable to the processed materiel.
 - (2) Engines. If the engine is filled with preservative lubricating oil, the preservative oil will be retained until the using service places equipment on scheduled maintenance. Install new engine oil filters where applicable.
 - (3) Gearcases. Transfer, transmission, differential, and other gearcases will be filled to operating level with prescribed seasonal grade lubricant if required.
 - (4) Lubrication. Lubricate materiel in accordance with instructions contained in LO 9-2320-244-12.

4-3. Shipping Instructions.

Shipping instructions applicable to M715, M725 and M726 vehicles are supplied in MIL-V-62038A (AT).

4-4. Loading and Blocking of Vehicles on Railroad Cars.

- a. General Loading of vehicles on cars for shipment by rail shall be in accordance with applicable requirements of Association of American Railroads.
- b. Army Shipping Documents. Prepare all Army Shipping Documents accompanying freight in accordance with TM 38-230-1.
- c. Shipment of Vehicle on Flat Car with Wood Floor.

- (1) Brake wheel clearance. Load vehicle on flat-car with minimum clearance of 12-inches from the flatcar brake wheel. Brake wheel clearance should be increased as much as it is consistent with proper location of load. The vehicle must be positioned on the flatcar with the wheels centrally located between the stake pockets, to provide uniform positioning of the tie down cables. Refer to Figure 4-1a and 4-1b.
- (2) Wheel chock blocks. Eight 6 x 8 x 24-inch blocks are required to block the vehicle. Locate the 450 surface of the blocks against the front and rear of each wheel. Nail heel of blocks to flatcar floor using 30-D nails and toenail both sides of blocks with 30-D nails. Chock blocks may be cut from timber, (or railroad ties, when available). Refer to figure 4-2.
- (3) Wheel side cleats. Nail 2 x 6 to 2 x 4 s with six 20-D nails. Place waterproof paper between tire and side cleat. Nail side cleat to flatcar floor with 40-D nails equally spaced. Refer to figure 4-3.
- (4) Cable tie down. Pass one end of the ½-inch steel cable through the vehicle towing shackle and the other end through a flatcar stake pocket. A ½-inch metal thimble is used to protect the steel cable where it passes through the flatcar stake pocket. Pull the steel cable tight removing all slack and secure with four ½-inch cable clamps. Refer to figure 4-4.
- (5) Vehicle secured on flat car. The 1-1/4 ton, 4 x 4 CARGO TRUCK M715 (fig 4-1) has not been processed for domestic freight shipment but simply illustrates the proper method of blocking vehicle on the flatcar.

4-5. Destruction of Materiel to Prevent Enemy Use.

Refer to TM 9-2320-244-10 for demolition of materiel to prevent enemy use.

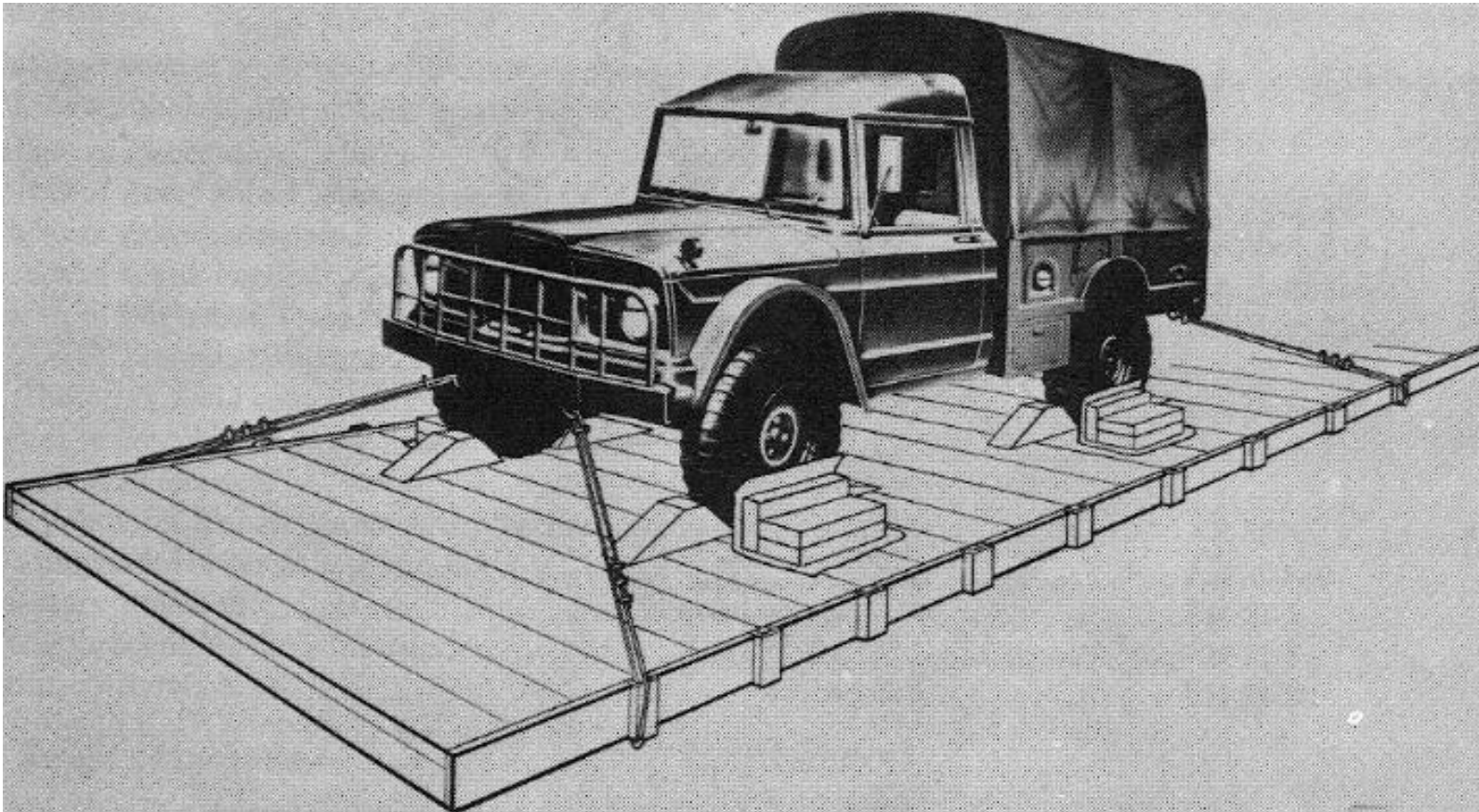

Figure 4-1a. Vehicle position on flatcar.

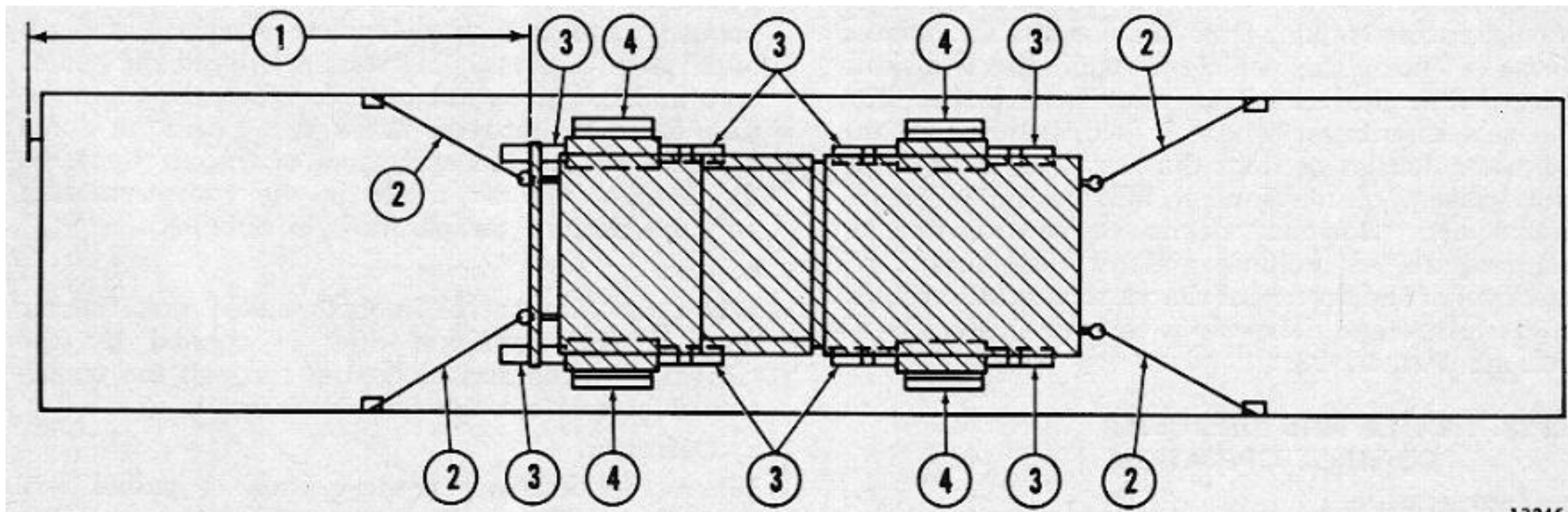

Figure 4-1b. Vehicle position on flatcar.

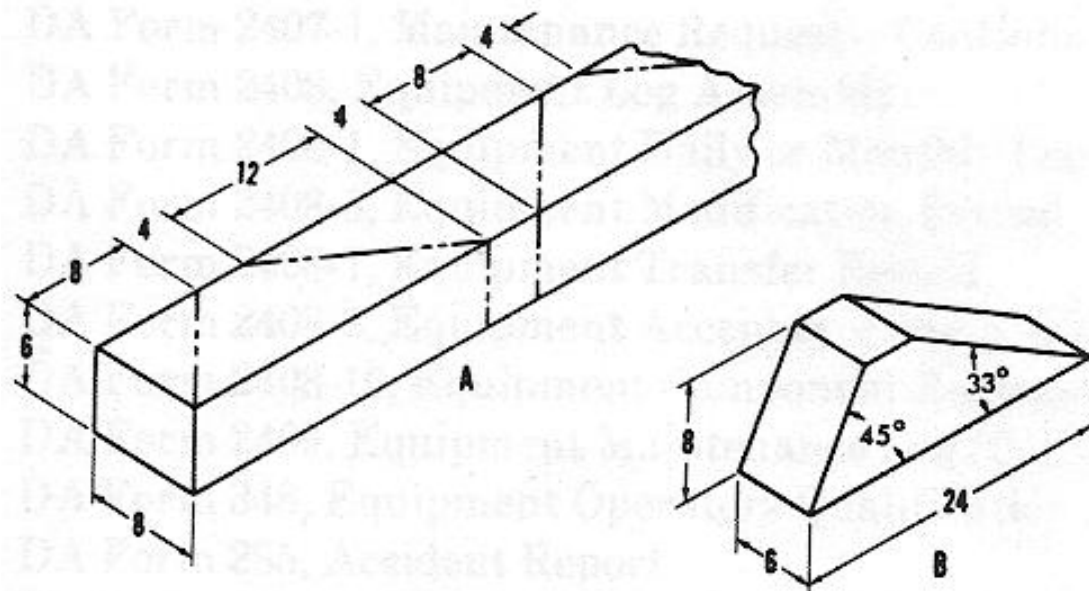

FIGURE 4-2. Cutting chock block from timber.

A Marking timber for cutting

B Chock block

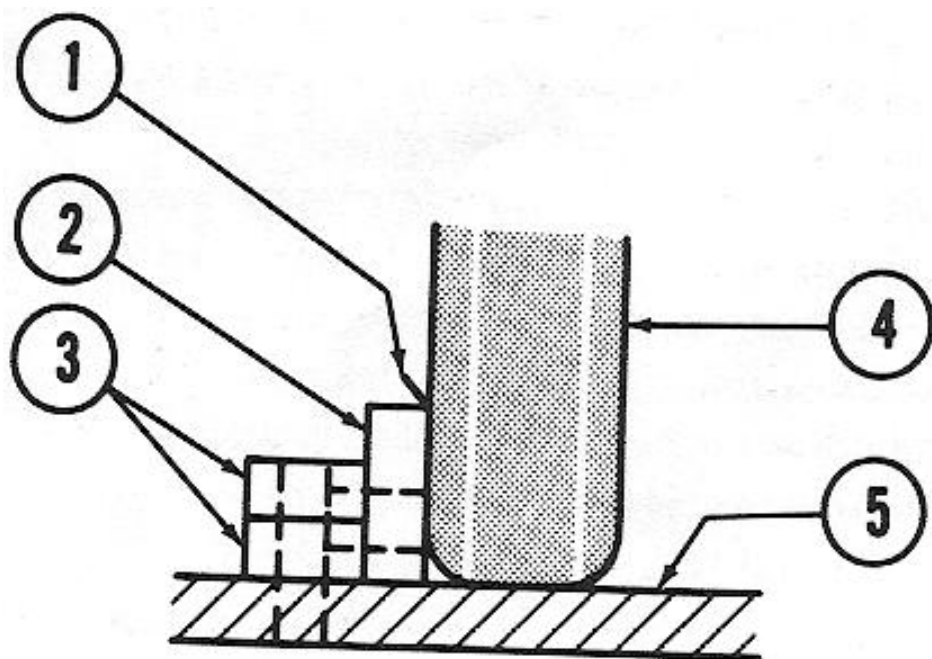

FIGURE 4-3. Wheel side cleats.

- 1 Waterproof paper
- 2 2-in x 6-inch x 30-inch timber
- S 2-inch x 4-inch x 30-inch timber
- 4 Tire
- 5 Flatcar floor

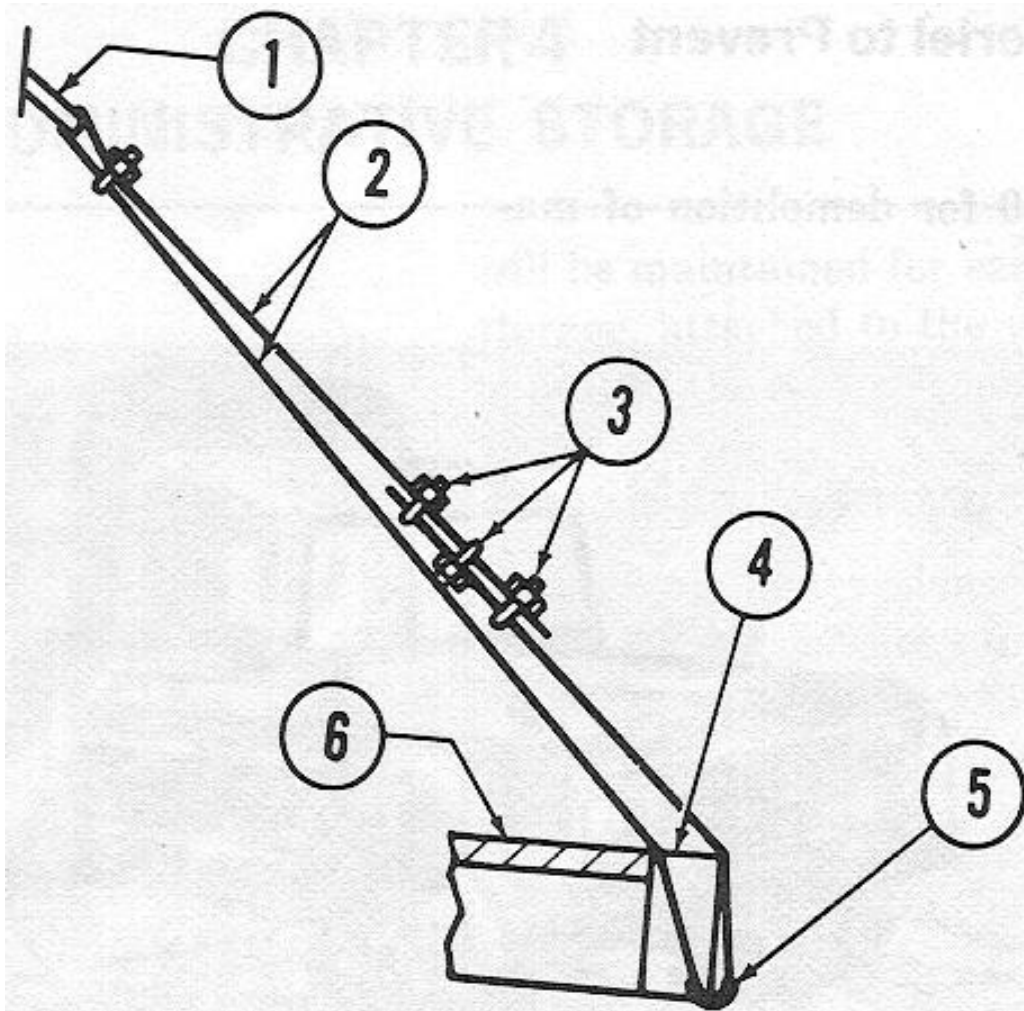

FIGURE 4-4. Cable tie downs.

- 1 Towing shackle
- 2 ½-inch steel cable
- 3 ½-inch cable clamp
- 4 Stake pocket
- 5 ½-inch steel thimble
- 6 Flatcar floor

APPENDIX A REFERENCES

A-1. Publication Indexes and General References.

Indexes should be consulted frequently for latest changes or revisions of references given in this appendix and for new publications relating to materiel

covered in this publication.

a. Military Publication Indexes.

Index of Army Films, Transparencies, GTA Charts, and Recordings DA Pam 08-1

Index of Administrative Publications DA Pam 310-1

Index of Blank Forms DA Pam 310-2

Index of Doctrinal, Training, and Organizational Publications DA Pam 310-3

Index of Technical Manuals, Technical Bulletins, Supply Manuals, Supply

Bulletins, Lubrication Orders DA Pam 310-4

Index of Graphic Training Aids and Devices DA Pam 310-5

b. General References.

Dictionary of United States Army Terms AR 320-5

Authorized Abbreviations and Brevity Codes AR 320-50

Military Training FM 21-5

Techniques of Military Instruction FM 21-6

Military Symbols FM 21-30

A-2. Supply Manuals

The following Department of the Army pertain to this materiel:

Tool Kit, Automotive Maintenance, Organizational Set No. 2, Supplemental
(4910-754-0650) (line item 453895) SC 4910-95-CL-A72

A-3. Forms.

The following forms pertain to this materiel. Refer to DA Pamphlet 310-2 for index of blank forms and to TM 38.750 for explanation on usage.

DA Form 2400, Equipment Utilization Record.

DA Form 2401, Organizational Control Record for Equipment.

DA Form 2402, Exchange Tag.

DA Form 2403, Preventive Maintenance Roster. -

DA Form 2405, Maintenance Request Register.

DA Form 2406, Materiel Readiness Report.

DA Form 2407 Maintenance Request

DA Form 2407-1 Maintenance Request Continuation Sheet

DA Form 2408, Equipment Log Assembly

D & Form 2408-1, Equipment Daily or Monthly Log

DA Form 2408-5, Equipment Modification Record.

DA Form 2408-7, Equipment Transfer Record.

DA Form 2408.8, Equipment Acceptance and Registration Record.

DA Form 2408-10, Equipment Component Register.

DA Form 2409, Equipment Maintenance Log (Consolidated).

DA Form 348, Equipment Operators Qualification Record.

DA Form 285, Accident Report.

DA Form 1089, Claim for Personal Property.

DD Form 6, Report of Damaged or Improper Shipment.

DD Form 314, Preventive Maintenance Schedule and Record.
DD Form 518, Accident Identification Card.
Standard Form 46, U. S. Government Motor Vehicle Operator s Identification Card.
Standard Form 91, Operator s Report of Motor Vehicle Accident (Card).

A-4. Other Publications.

The following publications contain information pertinent to major item materiel and associated equipment.

a. Vehicle.

Lubrication Order, Truck, Cargo, 1 1/4 Ton, 4 x 4, M715, Truck Maintenance, 1 1/4 Ton, 4 x 4, M726 and Truck, Ambulance, 1 1/4 Ton, 4 x 4, M725, LO 9-2320-244-12
Operator s Manual TM 9-2320-244-10
Organizational Maintenance Repair Parts and Special Tools List TM 9-2320-244-20P
Equipment Serviceability Criteria TM 9-2320-244-ESC

b. Camouflage.

Camouflage FM 5-20

c. Decontamination.

Chemical, Biological, and Radiological (CBR) Decontamination TM 3-220
Defense Against CBR Attack FM 21-40

d. General.

Accident Reporting and Records AR 385-40
Basic Cold Weather Manual FM 31-70
Cooling Systems: Vehicles and Powered Ground Equipment TM 9-2858
Manual for the Wheeled Vehicle Driver TM 21-305
Driver Selection and Training (Wheeled Vehicles) TM 21-300
Deep-Water Fording of Ordnance Materiel TM 9-238
Command Maintenance Management Inspections AR 750-8
Mountain Operations FM 31-72
Northern Operations FM 31-71
Operation and Maintenance of Army Materiel in Extreme Cold Weather (0°F to -65°F) TM9-207
Petroleum Handling Equipment and Operations TM 10-1101
Principles of Automotive Vehicles TM 9-8000
Prevention of Motor Vehicle Accidents AR 385-55
Organizational Maintenance Spark Plugs used on Ordnance Materiel TM 9-8638

e. Maintenance and Repair.

Organizational Maintenance of Pneumatic Tires and Tubes TM 9-2610-200-20
Cleaning of Ordnance Materiel TM 9-208-1
Combat Vehicles and Tactical Transport Vehicles: Procedure for starting Engines with Slave Cable TB ORD 537
Description, Use, Bonding Techniques, and Properties of Adhesives TB ORD 1032
General Supply:
Winterization Kits for Army Tank-Automotive Materiel SB 9-16

Inspection, Care and Maintenance of Antifriction Bearings TM 9-214

Tank-Automotive Gasoline Engines:

Lubrication Before Use TB ORD 392

Lubrication of Ordnance Materiel TM 9-273

Materials Used for Cleaning, Preserving, Abrading, and Cementing

Ordnance Materiel and Related Materiels Including Chemicals TM 9-247

Operation and Organizational, Field and Depot Maintenance: Storage batteries, Lead-Acid Type TM 9-6140-200-15

Ordnance Tracked and Wheeled Vehicle Hull and Chassis Wiring; Repair of Cracked or Peeled Plastic, Natural Rubber, or Synthetic Rubber Covered Conduit Cables TB ORD 650

Organization, Policies, and Responsibilities for Maintenance Operation AR 750-5

Painting Instructions for Field Use TM 9-213

Use of Antifreeze Solutions and Cleaning Compounds in Engine Cooling System TB 750-651

Welding Theory and Application TM 9-237

f. Shipment and Limited Storage.

Color and Marking of Army Materiel AR 746-5

Preservation, Packaging, and Packing of Military Supplies and Equipment TM 740-90-1

Preservation, Packaging and Packing Materiels, Supplies, and Equipment

Used by the Army SB 38-100

The Army Maintenance Management System (TAMMS) TM 38-750

APPENDIX B

TORQUE REQUIREMENTS

B-1. Special Torque Values.

The following items listed in Table B-1 are special torque requirements. They are torques of attaching hardware which are used for critical attachment and/or alinement of vehicle components. All the special torque items are listed in their appropriate sections throughout the manual and listed in this section for the convenience of the user.

Table B-1. Special Torque Requirements

OPERATION	TORQUE POUNDS FEET
Engine Torque Specifications:	
Alternator brace to adjusting strap	12-15
Alternator support bracket to block	15-30
Alternator to support bracket	25-30
Alternator adjusting strap to alternator	15-20
Alternator pulley nut	40-50

Cam bearing deck to cylinder head studs	12-15
Camshaft thrust plate to cam bearing deck nut	12-15
Carburetor to intake manifold nut	15-20
Chain guide bracket to cylinder block	12-15
Chain guide and pin assembly to chain cover	5-8
Connecting rod bolt cap nut	40-50
Cylinder block stud to chain cover nut	12-50
Cylinder head and cam bearing deck to cylinder block bolt	80-95
Cylinder head to cylinder block bolt	80-95
Exhaust manifold to cylinder head	25-30
Fan to pulley bolt	12-15
Filler block, front, to cylinder block screw	8-15
Filler block, rear, to cylinder block screw	15-20
Flywheel housing to cylinder block screw	27-42
Flywheel to crankshaft nut	35-40
Fuel line, intake, and spacer to oil pan screw	12-15
Fuel pump eccentric and sprocket to camshaft screw	40-45
Fuel pump to timing chain cover nut	12-15
Ignitor to timing chain cover nut	12-15
Insulator adapter bracket to block bolt	15-20
Insulator to front frame bracket	25-30
Insulator to transmission support	15-20
Intake manifold to cylinder head	15-20
Lifting eye to cylinder head screw	15-20
Lock and crank pulley to damper	25-30
Main bearing cap bolt	80-95
Oil filter to cylinder block	45-50
Oil flex line to cylinder head	30-35
Oil pan drain plug	25-30
Oil pan to cylinder block screw	10-17
Oil pump cover to oil pump	5-8

Oil pump to timing chain cover nut	12-20
Rocker arm cover mounting nut	5-8
Spark plug to cylinder head	26-30
Starter switch assembly to transmission cover	5-8
Starting motor to flywheel housing bolt	40-45
Timing chain cover to cylinder block bolt 5/16	12-20
Timing chain cover to cylinder block bolt 3/8	15-20
Timing chain cover to cylinder head bolt	12-20
Torque reaction arm to snubber	15-20
Vibration damper to crankshaft bolt	100-130
Water outlet elbow to intake manifold nut	15-20
Water pump to timing chain cover nut	12-15
Chassis Torque Specifications:	
Brake backing plate bolts (front and rear)	45-60
Clutch pressure plate to flywheel	25-30
Spring U-bolt (front)	90-100
Spring U-bolt (rear)	45-65
Propeller shaft U-joint flange	13-18
Rear axle shaft flange nut	32-50
Spring pivot bolts (rear)	35-40
Steering column shaft clamp	13-18
Steering gear to bracket	40-50
Steering arm nut	110-140
Steering knuckle arm nut	70-90
Steering wheel nut	18-30
Tie rod stud nut	70-90
Steering tie rod clamp bolts	38-42
Torque reaction arm to transmission	50-70
Transmission main shaft nut	130-170
Wheel to hub nuts	250-300

Body Torque Specifications:	
Front door hinges, to door, to pillar	25-30
Hood hinge to hood and to cowl	15-20

B-2. Standard Torque Values.

Table B-2 provides standard torque values for specific size and grade of bolts and screws utilized as attaching hardware for components and parts. If specific torque values are not specified in the appropriate component paragraphs, attaching hardware should be tightened to the to the torque values of table B-2.

Table B-2. Standard Torque Data

Bolt or Screw Size	Threads per inch	Diameter (inch)	SAE grade 2*		SAE grade 5**		SAE grade 7+		SAE grade 8++	
			Torque	Torque	Torque	Torque	Torque	Torque	Torque	Torque
			Dry	Wet	Dry	Wet	Dry	Wet	Dry	Wet
			pounds inch	pounds inch	pounds inch	pounds inch	pounds inch	pounds inch	pounds inch	pounds inch
4	40	0.1120	5	4	8	6	11	8	12	8
4	48	0.1120	6	5	9	7	12	9	13	10
6	32	0.1380	10	8	16	12	20	15	23	17
6	40	0.1380	12	9	18	13	22	17	29	19
8	32	0.1640	19	14	30	22	36	27	41	31
8	36	0.1640	20	15	31	23	38	29	43	32
10	24	0.1900	27	21	43	32	52	39	60	45
10	32	0.1900	31	23	49	36	60	45	68	51
1/4	20	0.2500	66	49	96	75	120	96	144	108
1/4	28	0.2500	76	56	120	86	144	108	168	120
			pounds foot	pounds foot	pounds foot	pounds foot	pounds foot	pounds foot	pounds foot	pounds foot
5/16	18	0.3125	11	8	17	13	21	16	25	18
5/16	24	0.3125	12	9	19	14	24	18	25	20
3/8	16	0.3750	20	15	30	23	40	30	45	35
3/8	24	0.3750	23	17	35	25	45	30	50	35
7/16	14	0.4375	30	24	50	35	60	45	70	55
7/16	20	0.4375	35	25	55	40	70	50	80	60
1/2	13	0.500	50	35	75	55	95	70	110	80

1/2	20	0.500	55	40	90	65	100	80	120	90
9/16	12	0.5625	65	50	110	80	135	100	150	110
9/16	18	0.5625	75	55	120	90	150	110	170	130
5/8	11	0.6250	90	70	150	110	190	140	220	170
5/8	18	0.6250	100	80	180	130	210	160	240	180
3/4	10	0.7500	160	120	260	200	320	240	380	280
3/4	16	0.7500	180	140	300	220	360	280	420	320
7/8	9	0.8750	140	110	400	300	520	400	600	460
7/8	14	0.8750	155	120	440	320	580	440	660	500
1	8	1.0000	220	160	580	440	800	600	900	680
1	12	1.0000	240	170	640	480	860	660	1000	740
1 1/8	7	1.1250	300	220	800	600	1120	840	1280	960
1 1/8	12	1.1250	340	260	880	660	1260	940	1440	1080
1 1/4	7	1.2500	420	320	1120	840	1580	1100	1820	1360
1 1/4	12	1.2500	460	360	1240	920	1760	1320	2000	1500
1 3/8	6	1.3750	560	420	1460	1100	2080	1560	2380	1780
1 3/8	12	1.3750	640	460	1680	1260	2380	1780	2720	2040
1 1/2	6	1.5000	740	560	1940	1460	2780	2080	3160	2360
1 1/2	12	1.5000	840	620	2200	1640	3100	2320	3560	2660

*Head marking-none **Head marking + Head marking ++ Head marking

ALPHABETICAL INDEX

Note: In each block is the Subject and the Paragraph in the book to refer to.

A		
Accelerator pedal: Maintenance and Adjustment 2-36h Removal 2-37h Installation 2-39h	Alternator pulley: Removal 2-62b Installation 2-64b	Alternator kit, 100 ampere: General 3-13 Removal 3-15 Installation 3-17
Administrative storage: General 4-1 Administrative storage instructions 4-2 Shipping instructions 4-3 Loading and blocking of vehicles on railroad cars 4-4	Alinement, front wheel 2-92c	Antifreeze solutions 2-46c

Air cleaner: Removal 2-36d and e Installation 2-39e	Alternator: General 2-60 Removal 2-62a Installation 2-64c	Arctic Enclosure 3-18, 3-22
Air intake hose: Removal 2-36d and e Installation 2-39e	Alternator bracket: Removal 2-62c Installation 2-64a	Axle shafts, rear: Removal 2-98e Installation 2-100d
B		
Batteries: Maintenance and Adjustment 2-66a General 2-65a Removal 2-67a Installation 2-69b	Blackout marker light: Removal 2-67h Installation 2-69g	Brake pedal: Maintenance and Adjustment 2-102e Removal 2-103e Installation 2-105e
Battery tray: Removal 2-67b Installation 2-69a	Body and Cab description 2-116	Brake drums: General 2-106d Removal 2-108c Installation 2-110b
Belt, drive: Maintenance and adjustment 2-46j Removal 2-47d Installation 2-49c	Bracket, lifting: Removal 2-113c Installation 2-115c	Brake system: Maintenance and adjustment 2-102a General 2-101 Bleeding 2-102d
Blackout driving light: Removal 2-67f Installation 2-69f	Brake lines, fittings and hoses: Removal 2-103c Installation 2-115c	Bumper, front: Removal 2-113d Installation 2-115b
C		
Cable and chain, winch: Removal 3-5d Installation 3-7c	Choke control cable: Maintenance and Adjustment 2-36g Removal 2-37g Installation 2-39g	Common tools and equipment 2-4
Cab, soft top: Removal 2-123b Installation 2-125b	Circuit breakers: General 2-65p	Coolant pump: Removal 2-47e Installation 2-49b
Carburetor: Maintenance and Adjustment 2-36a Filter service 2-36d Removal 2-37e Installation 2-39b	Cleaning 2-12	Coolant pump pulley: Removal 2-47b Installation 2-49c

Cargo compartment troop seats: Removal 2-123j Installation 2-125j	Clutch linkage: Maintenance and Adjustment 2-31 Removal 2-32c Installation 2-34a	Cooling system: Maintenance and Adjustment 2-46 General 2-45 Draining 2-46h Filling 2-46i
Cargo cover: Removal 2-123a Installation 2-125a	Coil, ignitor: Removal 2-52b Installation 2-54b	Crankcase ventilation valve: General 2-35d Removal 2-37d Installation 2-39i
D		
Deepwater fording equipment: General 3-8 Maintenance and Adjustment 3-9 Removal 3-10 Installation 3-12	Differential carrier, front 2-93f	Directional turn signal lights: Removal 2-67j Installation 2-69i
Description, cargo truck, ambulance truck and maintenance truck 1-7	Differential carrier, rear 2-98f	Dome light: Removal 2-67t Installation 2-69o
Description of materiel to prevent enemy use 1-6	Directional signal control assembly: Removal 2-67n Installation 2-69n	Driveshaft and universal joints: Removal 3-5a Installation 3-7a
E		
Electrical connector receptacle, trailer: Removal 2-67m Installation 2-69m	Engine insulator assembly (rear) Removal 2-23b Installation 2-24b	Exhaust fan assembly: General 2-116d Removal 2-118e Installation 2-120e
Electrical system, troubleshooting: General 2-15 Test equipment 2-17 System circuits 2-16	Engine temperature sending unit: Removal 2-47g Installation 2-49g	Exhaust fan motor switch: Removal 2-72m Installation 2-74l
Engine: Description 2-25a Cylinder compression test 2-26d Manifold vacuum test 2-26e Tune-up procedures 2-26f	Equipment serviceability criteria 1-3	Exhaust pipe: Removal 2-42e Installation 2-44b
Engine insulator assembly (front) Removal 2-23c Installation 2-24c	Errors, reporting of 1-4	Exhaust manifold: Removal 2-44a Installation 2-42g

F		
Fan, fan pulley and drive belts: Removal 2-47d Installation 2-49c	Front suspension: Maintenance and Adjustment 2-92 General 2-91	Fuel lines: General 2-35g
Fan shroud: Removal 2-47f Installation 2-49a	Forms and Records 1-2	Fuel pump: General 2-35e Testing 2-36b Removal 2-37b Installation 2-39c
Front axle: Drain ing 2-92e Filling 2-92f Removal 2-93f Installation 2-95f	Fuel filter element: General 2-35 Removal 2-37c Installation 2-39f	Fuel tank: Removal 2-37a Installation 2-39d
Front bumper: Removal 2-113d Installation 2-115b	Fuel indicator: Removal 2-72c Installation 2-74c	
G		
Gasoline can mounting bracket: Removal 2423g Installation 2-125g	General preliminary services 2-2	Governor: General . 2-35b Removal . . 2-37f Installation . . 2-39a
Gearshift lever: Removal 2-77 Installation 2-78		
H		
Handbrake: General 1-101b Maintenance and Adjustment 2-102b Removal 2-103b Installation 2-105b	Heater, patient compartment (ambulance): General 2416e Removal 2-118f Installation 2-120f	Horn assembly: Removal 2-72g Installation 2-74e
Handbrake lever: Removal 2-103g Installation 2-105g	Heater, personnel: General 3-23 Removal 3-25 Installation 3-27	Horn switch: Removal 2-72n Installation 2-74k

Headlights, service: Maintenance and Adjustment 2-66c Removal 2-67d Installation 2-69c	Hood panel and hood hinge: Removal 1-118b Installation 2-120b	Hubs, wheels: General 2-106 Removal . 2-109c Installation 2-110b
Headlight selector switch: Removal 2-72i Installation 274g		
I		
Identification and Tabulated Data 1-8	Ignition system General 2-50 Maintenance and Adjustment 2-51	Ignitor: General 2-50b Removal 2-52a Installation 2-54c
Ignitor Coil: Removal 2-52b Installation 2-54b	Ignition timing 2-51c	Instrument cluster: Removal 2-72a Installation 2-74d
Ignition switch: Removal 2-72h Installation 2-74f		
L		
Lifting brackets: Removal 2-113c Installation 2-115c	Light switch, main: Removal 2-72l Installation 2-74j	Lubrication instructions: General 2-8 Under unusual conditions 2-9
M		
Maintenance of materiel used in conjunction with vehicle 3-1, 3-2	Master cylinder: Removal 2-103c Installation 2-105c	Muffler: Removal 2-42d Installation 2-44d
Maintenance repair parts 2-6		
O		
Oil filter: Removal 2-27 Installation 2-29		
P		
Parts, special tools and equipment: Common tools and equipment 2-4 Maintenance repair parts 2-6 Special tools and equipment 2-5	Power plant: General 2-22 Removal 2-23a Installation 2-24a	Propeller shafts, vehicle: General 2-84 Removal 2-86b Installation 2-90a

Pintle: Removal 2-113a Installation 2-115e	Preventive maintenance services: General 2-10 Checks and services 2-11	Propeller shaft, winch: Removal 3-5a Installation 3-7a
Pitman arm: Removal 2-93e Installation 2-95e		
R		
Radiator Assembly: Removal 2-47b Installation 2-49e	Rear axle: General 2-96 Draining 2-97b Filling 2-97c Removal 2-98f Installation 2-100e	Reflectors: Removal 2-123h Installation 2-125h
Radiator hoses: Removal 2-47a Installation 2-49f	Rear view mirrors: Removal 2-123c Installation 2425c	Rifle brackets: Removal 2-123i Installation 2-125i
Radio interference suppression: General 2-18 Replacement 2-20 Testing 2-21		
S		
Seat and Seat Cushions: Removal 2418d Installation 2-120d	Spare tire carrier: Removal 2-113f Installation 2-115f	Starting motor: General 2-55 Removal 2-57a Installation 2-59b
Service brakes: Maintenance and adjustment 2-102a Removal 2-103a Installation 2-105a	Spark plugs: Maintenance and adjustment 2-51 Removal 2-52d Installation 2-54d	Starting switch: Removal 2-57b Installation 2-59a
Service upon receipt of materiel: General 2-1	Spark plug cables: Removal 2-52e Installation 2-54e	Steering column: Removal 2-93h Installation 2-95h
Shackles, towing: Removal 2-113b Installation 2-115d	Special tools and equipment 2-5	Steering linkage: Maintenance and adjustment 2-92 Removal . 2-93e Installation 2-95e
Shock absorber mounting pins, front: Removal 2-93g Installation 2-95b	Special preliminary services 2-3	Steering shaft joint: Removal 2-93i Installation 2-95g

Shock absorber mounting pins, rear: Removal 2-98b Installation 2-100b	Speedometer/odometer: Removal 2-72b Installation 2-74b	Steering wheel: Removal 2-93g Installation 2-95j
Shearpin, winch: Removal 35b Installation 3-7b	Spotlight: Removal 2-67p Installation 2-69p	Stoplight switch: Removal 2-72j Installation 2-74h
Shock absorbers, front: Removal 2-93a Installation 2-95c	Springs, front: Removal 2-93c Installation 2-95a	Surgical light: General 2-65l Removal 2-67q Installation 2-69q
Shock absorbers, rear: Removal 2-98a Installation 2-104k	Springs, rear: Removal 2-98c Installation 2-100a	Switch, Control Panel, ambulance heater: Removal 2-118h Installation 2-120h
T		
Tail and stoplight assembly: Removal 2-67j Installation 269j	Toe-in front wheel 2-92	Troop seats, cargo compartment: Removal 2-123j Installation 2-125j
Tailpipe: Removal 2-42c Installation 2-44e	Transfer case: General 2-79 Draining 2-80b Filling 2-80c Removal 2-81b Installation 2-83a	Troubleshooting vehicle 2-13
Thermostat: Removal 2-47c Installation 2-49d	Transfer case controls: Removal 2-81a Installation 2-83b	Troubleshooting electrical system 2-15
Tires: Removal 2-108a Installation 2-110d	Transmission: General 2-75 Draining 2-76b Filling 2-76c	
U		
Universal joints, propeller shafts: Removal 286b Disassembly 2-87 Reassembly . 2-89 Installation 2-90		
W		

Warning switch, brake: Removal 2-103d Installation 2-105d	Wheel hubs: General 2-106c Removal 2-108c Installation 2-110b	Windshield wiper blade: Removal 2-124d Installation 2-126d
Wheels and tires: General 2-106 Toe-in 2-92d Removal 2-108a Installation 1-110d	Winch and brackets: General 3-3 Maintenance and adjustment 3-4 Removal 35a Installation 3-7a	Windshield wiper blade arm: Removal 2-124e Installation 2-126e
Wheel bearings: Maintenance and adjustment 2-107b Removal 2-108d Installation 2-110a	Windshield: Removal 2-118c Installation 2-120c	Windshield wiper motor: Removal 2-124f Installation 2-126f
Wheel cylinders: Removal 2-103c Installation 2-105c		