

Owner's Manual Power Take-Offs

Effective: February 2007
Supersedes: HY25-1135-M1/US
November 2005

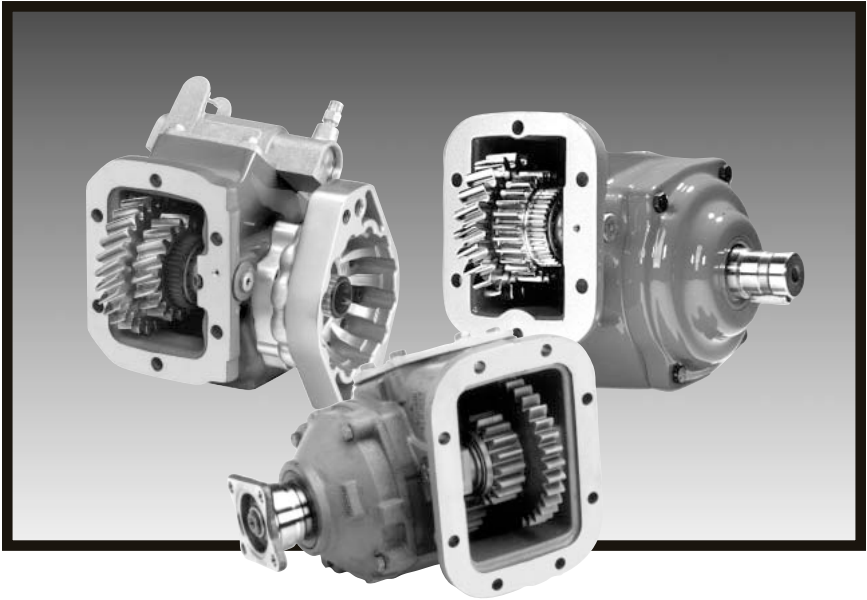

100 Series
221 Series
260 Series
290 Series
340 Series
352 Series
435 Series

436 Series
437 Series
438 Series
442 Series
447 Series
452 Series
489 Series

660 Series
680 Series
812 Series
823 Series
863 Series
880 Series

 **WARNING**

FAILURE OR IMPROPER SELECTION OR IMPROPER USE OF THE PRODUCTS AND/OR SYSTEMS DESCRIBED HEREIN OR RELATED ITEMS CAN CAUSE DEATH, PERSONAL INJURY AND PROPERTY DAMAGE.

This document and other information from Parker Hannifin Corporation, its subsidiaries and authorized distributors provide product and/or system options for further investigation by users having technical expertise. It is important that you analyze all aspects of your application and review the information concerning the product or system in the current product catalog. Due to the variety of operating conditions and applications for these products or systems, the user, through its own analysis and testing, is solely responsible for making the final selection of the products and systems and assuring that all performance, safety and warning requirements of the application are met.

The products described herein, including without limitation, product features, specifications, designs, availability and pricing, are subject to change by Parker Hannifin Corporation and its subsidiaries at any time without notice.

Offer of Sale

The items described in this document are hereby offered for sale by Parker Hannifin Corporation, its subsidiaries or its authorized distributors. This offer and its acceptance are governed by the provisions stated in the "Offer of Sale".

Patent Information

The Chelsea® Power Take-Off or its components shipped with this owner's manual may be manufactured under one or more of the following U.S. patents:

4610175 5228355 4597301 5645363 6151975 6142274 6260682 7159701 B2
Other patents pending.

© Copyright 2007, Parker Hannifin Corporation, All Rights Reserved

Contents**General Information**

| | |
|---|-----|
| Safety Information | 1-3 |
| Direct Mount Pump Support Recommendations | 4 |
| Foreword | 5 |
| P.T.O. Safety Labels Installation | 5 |

Installation Instructions

| | |
|---|-------|
| GMT3600 Cab-Chassis w/ZF | 7-15 |
| Mounting P.T.O. to Transmission 6 & 8 Bolts | 16-17 |
| 880/912 Split Shaft Installation | 18 |
| Checking Backlash | 19-20 |
| Adapter Plates, Filler Blocks, Adapter Assembly | 21 |
| Lubricant in Transmission/Inspect Installation | 22 |
| Function of Auxiliary Power Shafts | 23 |
| Spicer Universal Joint Engineering Data Quick Reference | 24 |

Wire Shift P.T.O.

| | |
|---|-------|
| Continuity Check (379639 & 379652 indicator switches) | 25 |
| Cable Control Installation | 26-30 |

Automatic Transmissions

| | |
|---|-------|
| Pressure Lube Hose Connection | 31 |
| 442 Series Pressure Lube for Allison 1000, 2000/2400 Series | 32 |
| P.T.O. Openings for Automatic Transmissions | 33-35 |

P.T.O. Shifting Procedure 36**Air Shift P.T.O. Installation Sketch**

| | |
|--|----|
| - 340 and 352 Series | 37 |
| - 880, 823 Series | 38 |
| - 100, 221, 260, 429, 434, 435, 436, 437, 438, 442, 447, 489, 660, 680 and 812 Series | 39 |

Electric Over Air Shift P.T.O. Installation Sketch

| | |
|--|----|
| - 100, 221, 260, 429, 434, 435, 436, 437, 438, 442, 447, 489, 660, 680 and 812 Series | 40 |
|--|----|

Installing Rotatable Flange 41**Indicator Light Installation** 42**Dash Drilling Templates** 42-44**P.T.O. Maintenance** 45**Offer of Sale** 46**Loose In This Booklet**

Mounting Gaskets
Sun Visor Decal

Safety Information

These instructions are for your safety and the safety of the end user. Read them carefully until you understand them.

General Safety Information

To prevent injury to yourself and/or damage to the equipment:

- Read carefully all owner's manuals, service manuals, and/or other instructions.
- Always follow proper procedures, and use proper tools and safety equipment.
- Be sure to receive proper training.
- Never work alone while under a vehicle or while repairing or maintaining equipment.
- Always use proper components in applications for which they are approved.
- Be sure to assemble components properly.
- Never use wornout or damaged components.
- Always block any raised or moving device that may injure a person working on or under a vehicle.
- Never operate the controls of the Power Take-Off or other driven equipment from any position that could result in getting caught in the moving machinery.

Proper Matching of P.T.O.



WARNING: A Power Take-Off must be properly matched to the vehicle transmission and to the auxiliary equipment being powered. An improperly matched Power Take-Off could cause severe damage to the vehicle transmission, the auxiliary driveshaft, and/or to the auxiliary equipment being powered. **Damaged components or equipment could malfunction causing serious personal injury to the vehicle operator or to others nearby.**

To avoid personal injury and/or equipment damage:

- Always refer to Chelsea catalogs, literature, and owner's manuals and follow Chelsea recommendations when selecting, installing, repairing, or operating a Power Take-Off.
- Never attempt to use a Power Take-Off not specifically recommended by Chelsea for the vehicle transmission.
- Always match the Power Take-Off's specified output capabilities to the requirements of the equipment to be powered.
- Never use a Power Take-Off whose range of speed could exceed the maximum safe speed of the equipment to be powered.



This symbol warns of possible personal injury.

Safety Information

Cold Weather Operation of Powershift P.T.O.s



WARNING: During extreme cold weather operation [32° F (0° C) and lower], a disengaged Powershift Power Take-Off can momentarily transmit high torque that will cause unexpected output shaft rotation. This is caused by the high viscosity of the transmission oil when it is extremely cold. As slippage occurs between the Power Take-Off clutch plates, the oil will rapidly heat up and the viscous drag will quickly decrease.

The Power Take-Off output shaft rotation could cause unexpected movement of the driven equipment resulting in serious personal injury, death, or equipment damage.

To avoid personal injury or equipment damage:

- Driven equipment must have separate controls.
- The driven equipment must be left in the disengaged position when not in operation.
- Do not operate the driven equipment until the vehicle is allowed to warm up.

Rotating Auxiliary Driveshafts



WARNING:



- Rotating auxiliary driveshafts are dangerous. You can snag clothes, skin, hair, hands, etc. This can cause serious injury or death.
- Do not go under the vehicle when the engine is running.
- Do not work on or near an exposed shaft when the engine is running.
- Shut off the engine before working on the Power Take-Off or driven equipment.
- Exposed rotating driveshafts must be guarded.

Guarding Auxiliary Driveshafts



WARNING: We strongly recommend that a Power Take-Off and a directly mounted pump be used to eliminate the auxiliary driveshaft whenever possible. If an auxiliary driveshaft is used and remains exposed after installation, it is the responsibility of the vehicle designer and P.T.O. installer to install a guard.



This symbol warns of possible personal injury.

Safety Information

Using Set Screws



WARNING: Auxiliary drivshafts may be installed with either recessed or protruding set screws. If you choose a square head set screw, you should be aware that it will protrude above the hub of the yoke and may be a point where clothes, skin, hair, hands, etc. could be snagged. A socket head set screw, which may not protrude above the hub of the yoke, does not permit the same amount of torquing as does a square head set screw. Also, a square head set screw, if used with a lock wire, will prevent loosening of the screw caused by vibration. Regardless of the choice made with respect to a set screw, an exposed rotating auxiliary driveshaft must be guarded.

Important: Safety Information and Owner's Manual

Chelsea Power Take-Offs are packaged with safety information decals, instructions, and an owner's manual. These items are located in the envelope with the P.T.O. mounting gaskets. Also, safety information and installation instructions are packaged with some individual parts and kits. Be sure to read the owner's manual before installing or operating the P.T.O. Always install the safety information decals according to the instructions provided. Place the owner's manual in the vehicle glove compartment.



WARNING: Operating the P.T.O. with the Vehicle in Motion

Some Power Take-Offs may be operated when the vehicle is in motion. To do so, the P.T.O. must have been properly selected to operate at highway speeds and correctly matched to the vehicle transmission and the requirements of the driven equipment.

If in doubt about the P.T.O.'s specifications and capabilities, avoid operating the P.T.O. when the vehicle is in motion. Improper application and/or operation can cause serious personal injury or premature failure of the vehicle, the driven equipment, and/or the P.T.O.

Always remember to disengage the P.T.O. when the driven equipment is not in operation.

Pump Installation Precautions (see next page)

Use a bracket to support the pump to the transmission if:

- The pump weighs **40 pounds** or more.
- The combined length of the P.T.O. and pump is **18 inches** or more from the P.T.O. centerline to the end of the pump.

Also remember to pack the female pilot of the P.T.O. pump flange with grease before installing the pump on the P.T.O.

CAUTION: When installing the 489 Series P.T.O. several direct mount pump flange options may interfere with the mounting fasteners directly under the flange. The nut must be threaded far enough onto the stud before the remaining (6) six capscrews and other nut are tightened to prevent interference with the flange and possible breakage of the P.T.O. housing.



This symbol warns of possible personal injury.

Direct Mount Pump Support Recommendations

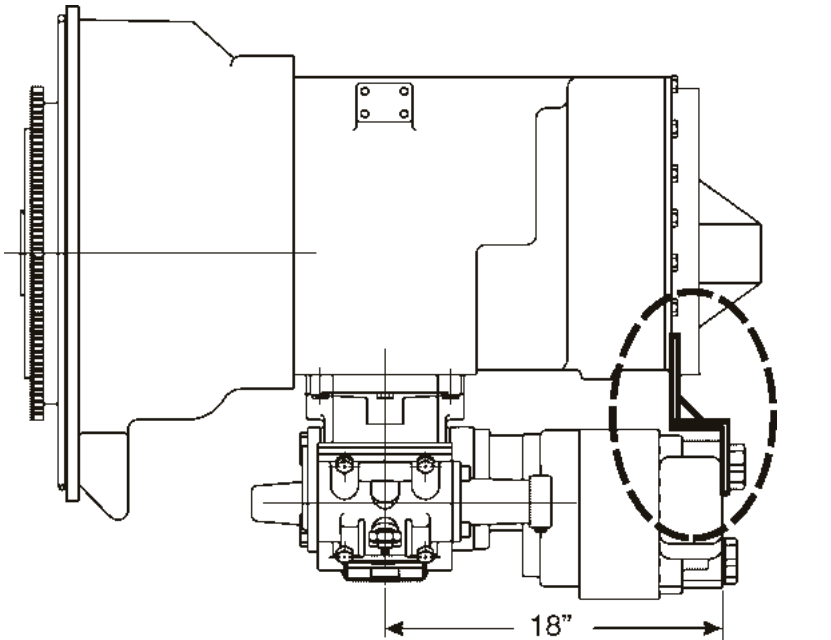

Note: For Proper Bracketing Attach At 2 or more Transmission Bolt Locations and 2 or More Pump Locations.

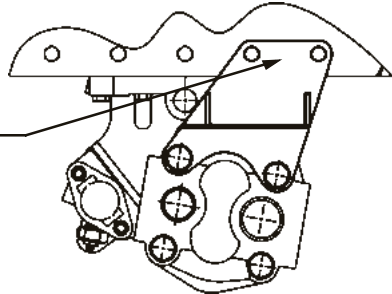

⚠ Use caution to ensure that bracket does not pre-load pump/ P.T.O. mounting

Chelsea strongly recommends the use of pump supports (Support Brackets) in all applications. P.T.O. warranty will be void if a pump bracket is not used when:

- 1) The combined weight of pump, fittings and hose exceed **40 pounds**.
- 2) The combined length of the P.T.O. and pump is **18 inches** or more from the P.T.O. centerline to the end of the pump.

ALSO: Remember to pack the female pilot of the P.T.O. pump shaft with grease before installing the pump on the P.T.O. (reference Chelsea grease pack 379688)

⚠ This symbol warns of possible personal injury.

Foreword

Since it is our major objective to show you how to get additional and more profitable miles from truck, tractor, and trailer components, we want to provide you with information on the installation of Chelsea Power Take-Offs.

We all realize that an inadequate transmission will overwork any power take-off in a very short period of time. In addition, a mismatched transmission/P.T.O. combination can result in unsatisfactory performance of the equipment right from the start.

Before you order new trucks, be sure that you're getting the right transmission/P.T.O. combination. This is vital for efficient performance and adequate power. To help you select the proper type, size, and design of P.T.O., discuss your specific requirements with a Chelsea P.T.O. specialist. They know their products and have easy access to equipment, transmission, and Power Take-Off manufacturers. They can tell you everything you need to know about power, at the right time, before you specify components.

Chelsea P.T.O. Safety Label Instructions

1. The two black and orange on white 5" x 7" pressure sensitive vinyl labels, part number 379274; must be placed on the vehicle frame rails (one (1) on each side), in a position that would be HIGHLY visible to anyone that would go under the truck near the P.T.O. rotating shaft. If the vehicle is to be painted after these labels are installed, cover them with two-(2) blank masking covers. Remove the masking covers after painting.
2. Place the one (1) black and orange on white 3.5" x 5" pressure sensitive vinyl label, part number 379275, on the visor nearest the operator of the vehicle, this must be placed near the P.T.O. visor label.
3. Place the one (1) red and white with black lettering 3.5" x 7.5" sensitive vinyl label, part number 379915, on the opposite side of the visor from the above label # 379275.
4. Place the one (1) white and black heavy duty card, part number 379276, in the vehicle glove box. Again in a position highly visible to the operator, for example: try to place this card on top of whatever may be in the glove box.

If you require additional labels, please order part number 328946X at no charge from your local Chelsea Warehouse or send request direct to:

**Parker Hannifin Corporation
Chelsea Products Division
8225 Hacks Cross Road
Olive Branch, MS 38654
Customer Service: (662) 895-1011**

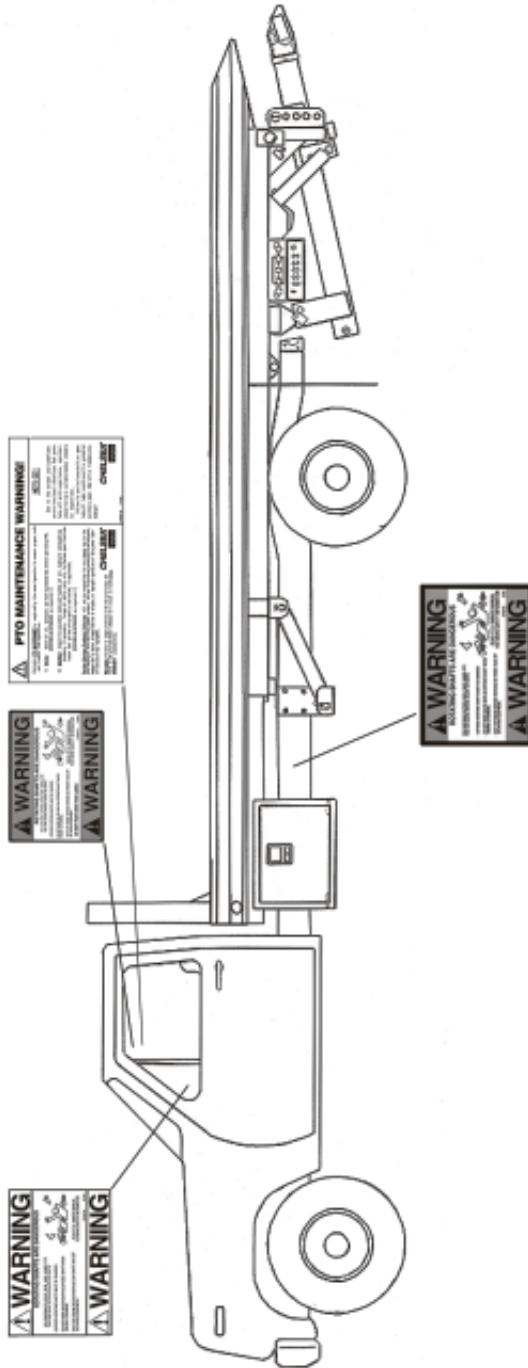

GMT3600 Cab-Chassis W/ZF Overview

P.T.O. provisions have been provided as standard content (“forced” options) on the 2001MY C/K 3600 (Cab-Chassis) trucks with 8.1L Vortec and 6.6L Duramax Diesel engines. These provisions are included in two “forced” options, M1F and P.T.O. M1F contains provisions for P.T.O. packaging. P.T.O. contains provisions for P.T.O. Engagement Control and P.T.O. Engine Speed Control. Both options are standard on the C/K 3600 cab-chassis trucks with the 8.1L and 6.6L engines.

M1F-provides for mounting space for transmission mounted Power Take-Off. P.T.O. mounting space is for the right hand side of the transmission. With the ZF S6-650 manual transmissions there are two (2) openings for P.T.O. applications. The right opening requires the use of a heat shield, direct mount pumps and hard line hydraulic tubes for installation along with a Chelsea® 442 Series Power Take-Off. Left side applications do not require the extra “hardware” for installation, but may not be usable on 4x4 vehicles due to the transfer case to front axle driveshaft.

P.T.O.-provides Engine Speed Control. P.T.O. includes the following:

- P.T.O. engine control software in Powertrain Control Module (PCM)
- Wiring provisions for in-cab P.T.O. Control Switch
- Upfitter P.T.O. Interface Connector which is located at the left side of the transmission.

Two P.T.O. operating speed control modes are available with the 8.1L Vortec and 6.6L Duramax Diesel engine. The PowerTrain Control Module (PCM) may be programmed to one of the following modes.

- Preset – Up to two* preset P.T.O. operating speeds.
- Variable – Allows variable P.T.O. speeds while vehicle is stationary or moving.

* Requires Cruise Control to control second preset speed.

Refer to GM Truck Owner's Manual for Complete Information on PCM Operations

Right Side Aperture Pre-Installation

1. Drain oil from transmission. Drain plug is located on the left side of the transmission.
2. If the vehicle is equipped with the 8.1L Gas Engine, it may be necessary to remove the three (3) bolts & studs that connect the right exhaust pipe and the right side engine exhaust header. (Fig. 1) This will allow the exhaust pipe to be moved slightly away from the P.T.O. opening for installation of the P.T.O. to the aperture pad.
3. Remove the transmission P.T.O. aperture cover and gasket. Make sure the aperture surface is clean and dry (Fig. 2).
4. Install the six studs and torque to 17-19 lbs. ft. [23-26 N.m] (Fig. 3).

CAUTION: Over tightening of studs may damage stud threads or transmission case threads if studs are not installed correctly. Use of air impact tools is not recommended.



Fig. 1

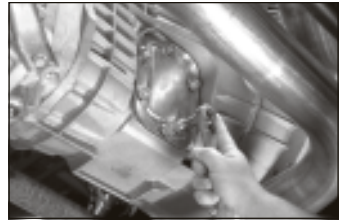

Fig. 2



Fig. 3

P.T.O. Installation – Checking Backlash

5. Using your hand, rock the P.T.O. driver gear in the transmission and the driver gear in the P.T.O. assembly. Rocking the gears provides two important factors (Fig 4).
 - a) It shows you the amount of backlash that has been designed into each unit.
 - b) It is helpful in establishing the proper backlash when installing the P.T.O.
6. Place the correct number of gaskets over studs (Fig. 5). Do not use Permatex between gaskets because you may want to add or subtract gaskets to obtain proper backlash.
 - When mounting a P.T.O. use gaskets between all mounting surfaces.
 - Do not stack more than 3 gaskets together.
 - Usually one thick gasket .020" (.50mm) will be required.
 - Remember the lubricant in the transmission also lubricates the P.T.O. Therefore, at least one gasket must be used on either side of filler blocks, adapter assembly or adapter plates. More gaskets may be required when establishing proper backlash.
7. Secure P.T.O. to aperture pad. Torque nuts to 35 – 40 lbs. ft. [47-54 N.m].
8. Check backlash as in any 442 Series installation [see page 19 of HY25-1135-M1/US].
9. Remove P.T.O. at this point.

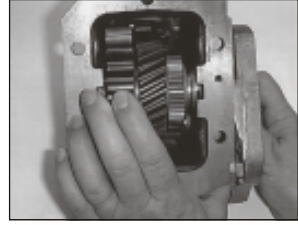

Fig. 4



Fig. 5

P.T.O. & Pump Pre-Installation

- Next install the pump flange as shown in Fig. 6. With the P.T.O. on the workbench, shifter cover facing towards you and the belly of the P.T.O. down, the flange shown should be towards your right. Orient the pump flange to the 3:30 – 9:30 position. Install the 6 socket head capscrews (378446-4) and torque to 8-12 lbs. ft. [11-16 N.m].
- It will be necessary to rotate the P.T.O. shift lever 180° from the position it is normally positioned (Fig. 7 & 8).
- On the closed end bearing cap remove the bottom left cap bolt as shown in Fig. 9. This will be used later to attach the heat shield.
- Install the pump with the “bulge up”*. Attach the P.T.O. heat shield bracket (379862) to the pump bolt as shown in Fig. 10 (suction port side closest to transmission). Torque pump bolts to 32-37 lbs. ft. [45-50 N.m.]

* Before attaching pump, pack the female pilot of the pump shaft with grease (Chelsea grease pack 379688).

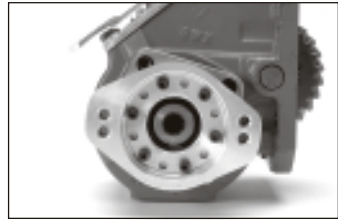

Fig. 6

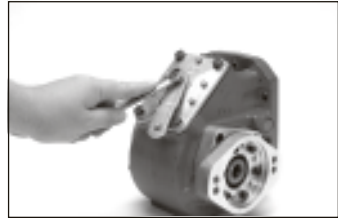

Fig. 7



Fig. 8

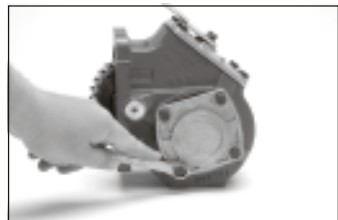

Fig. 9

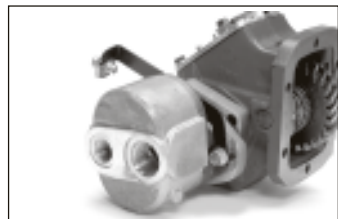

Fig. 10

P.T.O. & Pump Pre-Installation (Continued)

14. Install the two fittings for suction and discharge in the ports on the pump. Due to the angle of the fittings, install the discharge port fitting first. Do not tighten these fittings at this time (See Fig. 11 & 12). Screw fittings in by hand until back-up washer contacts the face of the boss.

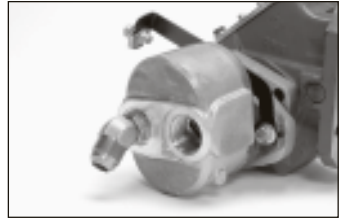

Fig. 11

NOTE: CGP-P14 shown for installation purposes. CGP-P5 and CGP-P11 pumps require additional fittings to connect the pump to the hydraulic tubes. See Chart below.

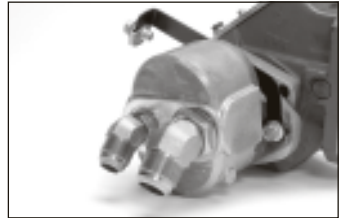

Fig. 12

| Pump Series | Fitting Kit | Swivel Nut Suction | Std Th'd O-Ring Suction | Swivel Nut Discharge | Std Th'd O-Ring Discharge |
|-------------|-------------|--------------------|-------------------------|----------------------|---------------------------|
| CGP-P5 | 329335-1X | 379866* | 379870 | 379868* | 379869 |
| CGP-P11 | 329335-2X | 379866* | 379867 | - | 379850* |
| CGP-P14 | 329335-3X | - | 379849* | - | 379850* |

* 45° Elbow Fitting

15. We will now move to the attachment of the hydraulic hard lines to the support bracket (379848). First attach the pump discharge tube (379845) with tube clamp (501211-8). Next install the pump suction tube (379846) with tube clamp (501211-12). Insert bolt (379706) through both tube clamps and top of bracket. Tighten nut (379141-9) onto bolt under bracket (Fig. 13 & 14).



Fig. 13

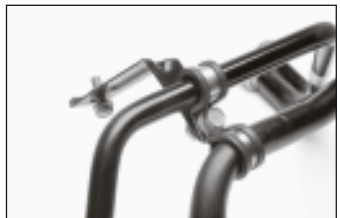

Fig. 14

Mounting P.T.O./Pump to the Transmission

16. Secure P.T.O./Pump to the transmission. (Fig. 15)

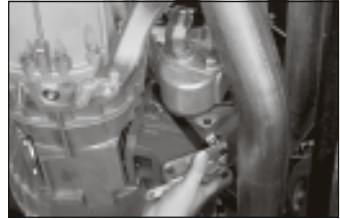

Fig. 15

17. Use Self Locking nuts provided with P.T.O. (Fig.16)
NOTE: Self-Locking nuts do not require lock washers.

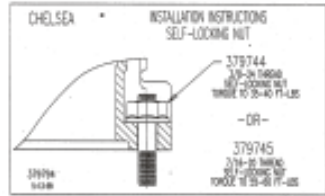

Fig. 16

18. Fasten the P.T.O. to the transmission (Fig. 17).
Torque the set of self-locking nuts (379744) to 35-40 lbs. ft. [47-54 N.m].

19. If Installing Engine/P.T.O. Interface Wiring Harness Kit 329333-4X follow steps 20 & 21.
If not skip to step 22.

20. Locate the GM upfitter P.T.O. interface connector, located on the upper left side of the transmission. Connect Chelsea supplied wiring harness (379895) to the interface connector (Fig.18).



Fig. 17

21. Run wiring harness over top of transmission and connect the booted connector to the P.T.O. indicator switch (Fig. 19). See page 14 of this manual for in dash switch installation. Secure harness to the transmission to protect the relay from damage.



Fig. 18



Fig. 19

Mounting P.T.O./Pump to the Transmission

22. On the right side of the transmission is a bracket for the oxygen sensor wiring harness (for California vehicle w/8.1L engines). This bracket is on all vehicles and may interfere with the hydraulic tubes. If the oxygen sensor wiring harness is on the vehicle, bend the bracket in towards the center of the transmission. If the vehicle has only the bracket, the bracket may be removed and the bolt torqued to 17 lbs. ft. [23 N.m]. Do not apply sealant to bolt (Fig. 20).
23. Next attach hydraulic tubes to the pump and tighten the fittings to the pump and tube nuts (Fig. 21). Position the fitting by backing out (counter-clockwise) up to one full turn. Hold fitting and tubing in desired position and tighten lock nut with a wrench. Assemble tube to fitting by tightening the assembly with wrench until solid feeling is encountered. From that point, apply one-sixth turn.
24. Attach hydraulic tube support bracket (379848) to the transmission (Fig. 22).
25. Install P.T.O. Heat Shield (379847) to the P.T.O. (Fig. 23). The heat shield is attached to the closed bearing cap by re-installing capscrew (378430-10) to the bearing cap and hex capscrew (378430-8) to the heat shield support bracket. Torque 378430-10 to 16-20 lbs. ft. [22-27 N.m].
26. Reinstall the three engine exhaust flange studs and attach pipe with nuts. Torque the nuts to 39 lbs. ft. [50 N.m]
27. Refill transmission with GM recommended fluid. [See page 22](#) of this manual for complete details.
28. Refer to page 25-30 of this manual for procedures on indicator continuity check and cable shift installation.

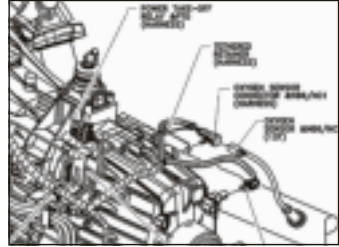

Fig. 20

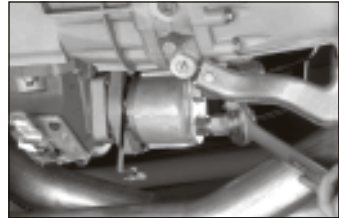

Fig. 21



Fig. 22



Fig. 23

P.T.O. Shifting Procedures & Precautions

This vehicle is equipped with a **POWER TAKE-OFF**
Shut Engine Off Before Working on Power Take-Off or Getting Below Vehicle.
Consult Operating Instructions Before Using. (See Sun Visor)

Power Take-Off Operation Vehicle Stationary

Manual Transmission

1. A Power Take-Off is, and should be, operated as an integral part of the main transmission.
2. Before shifting the Power Take-Off into or out of gear disengage the clutch and wait for the transmission or P.T.O. gears to stop rotating
3. Set parking brake
4. Shift the transmission into NEUTRAL (N)
5. Shift P.T.O. into gear
6. Release the clutch pedal
7. * Turn the dash mounted P.T.O./Engine control switch to the ON position. The engine speed will increase to the P.T.O. Standby Speed.

NOTE: The LED on the P.T.O./Engine control switch will change from blinking to steady state when the P.T.O. is engaged.

8. * Press either the SET or Resume switch on the cruise control or turn the P.T.O. switch to the set position. The engine speed will jump to the P.T.O. SET or RESUME speeds.

* Optional P.T.O. Interface Wiring Harness/In Dash Switch for Engine Speed Control.
See GM Truck Owner's Manual for complete engine control speed operations.

IMPORTANT: Failure to follow proper shifting or operating sequences will result in premature P.T.O. failure with possible damage to other equipment.



WARNING

Do not attempt to work on an installed Power Take-Off with the engine running.

Make sure to block any moving or raised device that may injure a person working on or under the truck. A lever or its linkage may be accidentally moved causing movement of the device, which could cause injury to a person near the device.

 **This symbol warns of possible personal injury.**

P.T.O. to GM P.T.O. Interface Connector 442 Series w/Wire Shift

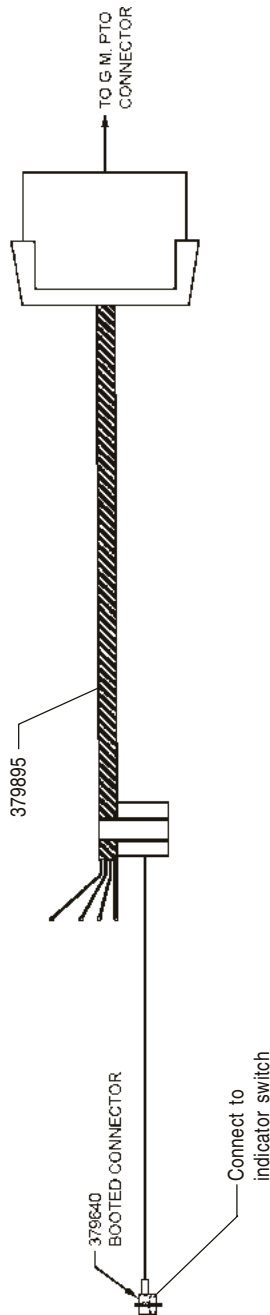

Mounting the P.T.O. on the Transmission For 6 or 8 Bolt Applications

1. Drain the oil from the transmission and remove the P.T.O. aperture cover plate (Fig. 1).
2. Discard the cover plate and cover plate gasket then clean the aperture pad using a putty knife or wire brush (Fig. 2).

NOTE: Stuff a rag in the aperture opening to prevent dirt from entering the transmission while you are cleaning it.

3. Using your hand, rock the P.T.O. driver gear in the transmission (Fig. 3) and the driven gear in the P.T.O. assembly (Fig. 4). Rocking the gears provides two important factors.
 - a) It shows you the amount of backlash that has been designed into each unit.
 - b) It is helpful in establishing the proper backlash when installing the P.T.O.

4. Install the proper studs (furnished with P.T.O.) in the P.T.O. aperture pad using a stud driver. Studs may have either interference fit threads (plain) or preapplied locking/sealing compound (See Figure 5 for installation method).
5. Where holes are tapped through the transmission case, use studs with preapplied locking & sealing compound Locktite 290 to prevent leaks.

NOTE: Avoid contact of Permatex with automatic transmission fluid in automatics. Always check to be sure that the studs do not interfere with transmission gears.



Fig. 1



Fig. 2



Fig. 3

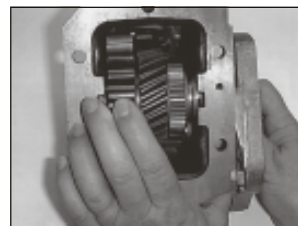

Fig. 4



Fig. 5

Mounting the P.T.O. on the Transmission (Continued)

6. Tighten studs securely and torque to 17-19 lbs. ft. (2.35-2.63 kg meters) for 6 bolt and 19-21 lbs. ft. (2.63-2.90 kg meters) for 8 bolt. **CAUTION: overtightening of studs may damage stud and/or transmission threads** (Fig. 6).
7. Place the correct number of gaskets over studs (Fig. 7). Do not use Permatex between gaskets because you may want to add or subtract gaskets to obtain proper backlash.
 - When mounting a P.T.O. use gaskets between all mounting surfaces.
 - Do not stack more than 3 gaskets together.
 - Usually one thick gasket .020 (.50mm) will be required.
 - Remember the lubricant in the transmission also lubricates the P.T.O. Therefore, at least one gasket must always be used on either side of filler blocks, adapter assemblies or adapter plates. More gaskets may be required when establishing proper backlash.
8. Secure P.T.O. to the transmission.
 - Use Self Locking nuts provided with P.T.O. (Fig. 8). **NOTE: Self Locking nuts do not require lock washers.**
9. Fasten the P.T.O. to the transmission (Fig. 9). Torque the set of locking nuts to their proper specifications.
 - 379744-3/8"-24 for 6-bolt applications 35-40 lbs. ft. (4.83-5.52 kg.m)
 - 379745-7/16"-20 for 8-bolt applications 55-60 lbs. ft. (7.59-8.28 kg.m)Torque capscrews to their proper specifications.
 - 6-bolt to 30-35 lbs. ft. (4.14-4.84 kg.m)
 - 8-bolt to 45-50 lbs. ft. (6.22-6.91 kg.m)



Fig. 6



Fig. 7

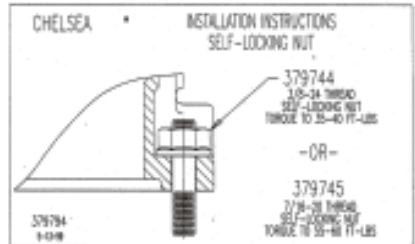

Fig. 8

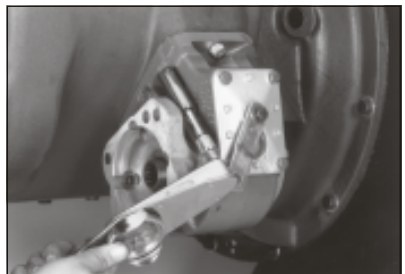
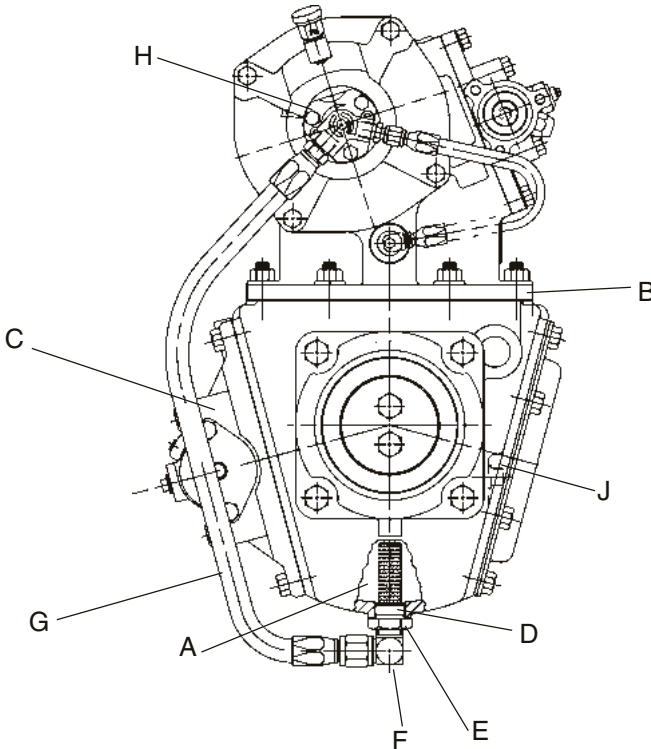

Fig. 9

Installation Instructions for 880 Series with "L" Output, Top Mounted to 912 Series Split Shaft - Requiring Self-Lube Option

1. Drain split shaft oil at drain plug (A). Filter or screen oil & reuse if desired.
2. Remove top split shaft aperture cover plate at (B) or air shift Assembly (C) & reassemble to either side of split shaft in place of shipping cover. Install P.T.O. on split shaft & set backlash at .006" to .012". (See page 19 for checking proper backlash)
3. Install copper gasket (D), screened strain plug (E) & 90° elbow (F) in place of drain plug at (A). Also install pressure lube hose (G) between elbow (F) and pump (H). (Use pipe sealant on all pipe threads)
4. Fill split shaft with filtered, screened or new oil at fill plug (J), until oil reaches plug level, then reinstall plug.
5. Finish P.T.O. & split shaft installation per owner's manual. Also install shaft and/or pump to be driven by P.T.O.
6. After brief P.T.O. operation, remove fill plug (J), add oil until it reaches plug level, then reinstall plug.

IMPORTANT: Lube pump (H) must rotate clockwise (engine rotation) as view from front of vehicle.



Checking Backlash

To check for proper backlash on P.T.O.s with shift cover

1. Remove the P.T.O. shift housing and/or inspection plate.
2. Mount the dial indicator so that it registers movement of the input gear (driven gear) of the P.T.O. (Fig. 10).

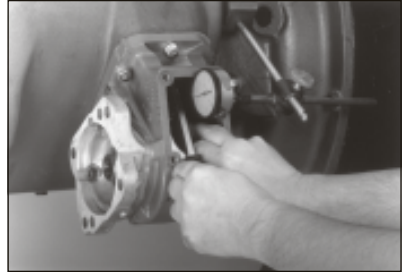

Fig. 10

NOTE: See Figure 11 for proper location of dial indicator contact point. (Two common type dial indicators shown).

3. Hold the P.T.O. driver gear in transmission with a screwdriver or bar and rock the P.T.O. input gear (driven gear) back and forth with your hand. Note the total movement on the dial indicator.

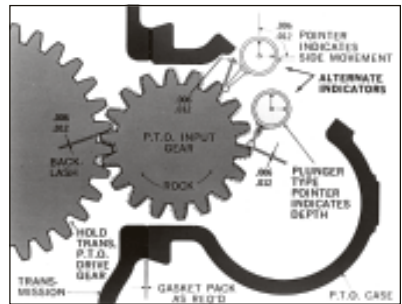

Fig. 11

4. Establish backlash at .006"-.012" [.15mm-.30mm] by adding or subtracting gaskets.

General rule: A Chelsea .010" gasket will change backlash approx. .006". A .020" gasket changes backlash approx. .012".

NOTE: When using a 221 or 260 Series P.T.O. with the AJ gear designation on an Allison Automatic transmission with a six bolt opening, a special gasket (35-P-41) is supplied. When installed with the P.T.O. this gasket reduces the need for backlash adjustment.

5. Replace the shift housing and/or inspection plate and retorque (4) four capscrews to 16-20 lbs. ft. (2.21-2.76 kg meters).

NOTE: Apply a drop of Loctite 290 on each capscrew before reinstalling. Capscrews that are furnished with a conversion kit and are being installed for the first time do not require the drop of Loctite.

2 Gear-8-Bolts - 863

An inspection hole is provided in the P.T.O. housing for feeling the mounted backlash.

Rock the P.T.O. Input Gear with your hand and correlate this backlash to the unmounted backlash found in step 3 on [page 19](#). Use Gaskets to get backlash feel as close to unmounted condition as possible.



Fig. 12

Adapter Plates

Adapter plates are used to permit mounting a 6 bolt P.T.O. on a transmission that has an 8 bolt aperture.

NOTE: A wire locking stud kit is recommended when mounting a 6 bolt P.T.O. to an adapter plate on a bottom opening.



Fig. 13

Filler Blocks

Filler blocks may be required where it is necessary to use a spacer to mount the Power Take-Off to a particular transmission

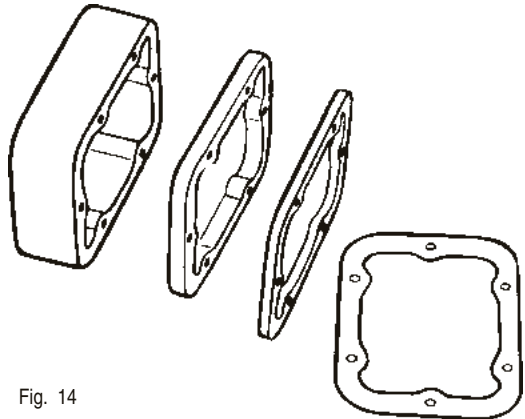

Fig. 14

P.T.O. Application and Adapter Assembly

Figure 15 illustrates typical adapter assembly configurations. Some P.T.O. applications require adapter assemblies because it is impossible to reach the P.T.O. driver gear in the transmission without this assembly. An adapter assembly will change the rotation of the P.T.O. and this may be necessary for driving pumps or other accessory equipment. Obstructions, such as bulge in the transmission, exhaust pipes or motor mounts can sometimes be compensated for through the use of an adapter.



Fig. 15

Refer to Adapter Gears Owners Manual HY25-1670-M1/US.

Lubricant in Transmission/Inspect Installation

1. Remove the filler plug from the transmission and add recommended transmission lubricant to the level prescribed by the transmission or truck manufacturer (Fig. 22).

NOTE: If the P.T.O. is mounted below oil level, additional lubricant will be required.

2. Run the P.T.O. for 5-10 minutes and check for oil leaks and noise.
3. Should a quiet P.T.O. become noisy after the universal joint connection is made, check the P.T.O. driveline components for an out of phase condition, excessive or unequal joint angles or possibly worn parts in the driven accessory.
4. Re-torque all mounting bolts, nuts, cap screws and set up inspection routine of the P.T.O. driveline components and the driven auxiliary equipment.

NOTE: Anticipate slight increase in P.T.O. noise level as oil thins out at operating temperatures.

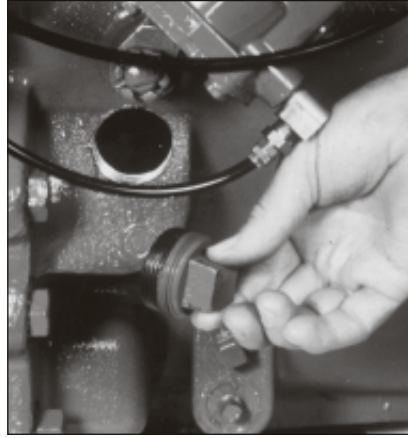

Fig. 22

P.T.O. Installation Tips for Automatic Transmissions

The procedure for installing a P.T.O. on an automatic is basically the same as for a mechanical transmission. Power Take-Offs for automatic transmissions are assembled with a special drilled input shaft which allows the input gear to be pressure lubricated during operation. (See page 31 and 32).

After installing a P.T.O. on an automatic transmission, connect pressure lubrication hose to the P.T.O. and the transmission per installation instructions shown on [pages 33-35](#) of this booklet.



WARNING: Adapter assemblies are never used on an automatic transmission because they do not have pressure lubricated design features.



WARNING: Use only wire control with P.T.O. made for wire cable control. If lever is desired, order P.T.O. for level control. The internal shifting mechanism for wire is not designed for heavy forces usually encountered with lever control linkage.



This symbol warns of possible personal injury.

Function of Auxiliary Power Shafts

An auxiliary power shaft transmits torque from the power source to the driven accessory. The shaft must be capable of transmitting the maximum torque and R.P.M. required of the accessory, plus any shock loads that develop.

An auxiliary power shaft operates through constantly relative angles between the power source and the driven accessory, therefore, the length of the auxiliary power shaft must be capable of changing while transmitting torque. This length change, commonly called "slip movement", is caused by movement of the power train due to torque reactions and chassis deflections.

Joint operating angles are very important in an auxiliary power joint application. In many cases, the longevity of a joint is dependent on the operating angles. (See chart below)

This information is limited to 1000 through 1310 series applications. For applications requiring a series larger than 1310, contact your local Chelsea distributor.

| SPICER® UNIVERSAL JOINT OPERATING ANGLES | | | |
|--|-----------------------------|--------------------|-----------------------------|
| PROP. SHAFT R.P.M. | MAX. NORMAL OPERATING ANGLE | PROP. SHAFT R.P.M. | MAX. NORMAL OPERATING ANGLE |
| 3000 | 5° 50' | 1500 | 11° 30' |
| 2500 | 7° 00' | 1000 | 11° 30' |
| 2000 | 8° 40' | 500 | 11° 30' |

Above based on angular acceleration of 100 RAD/SEC²

Determining Shaft Type

1. Solid or tubular?
 - a. In applications requiring more than 1000 R.P.M. or where the application necessitates a highly balanced auxiliary power shaft, a tubular shaft should be used.
 - b. Spicer® solid shafting auxiliary power joints are designed for 1000 or less R.P.M. intermittent service such as:
 - Driving small hydraulic pumps
 - Driving winches
 - Driving low speed product pumps
2. Joint series should be determined using the following chart.

Spicer® Universal Joint Engineering Data Quick Reference Chart

| JOINT SERIES | 1000 | 1100 | 1280 | 1310 |
|--|-----------------------------|-----------------------------|-----------------------------|-----------------------------|
| TORQUE RATING Automotive (Gas or Diesel Engine) lbs. ft. Continuous | 50 | 54 | 95 | 130 |
| TUBING Diameter Wall Thickness W = WELDED S = SEAMLESS | 1.750 .065 W | 1.250 .095 S | 2.500 .083 W | 3.00 .083 W |
| FLANGE DIAMETER (Swing Diameter) Rectangular Type | 3.500 | 3.500 | 3.875 | 3.875 |
| BOLT HOLES - Flange Yoke Circle Diameter Number Male Pilot Dia. | 2.750 .312 4 2.250 | 2.750 .312 4 2.250 | 3.125 .375 4 2.375 | 3.125 .375 4 2.375 |
| DISTANCE ACROSS LUGS Snap Ring Construction | 2.188 | 2.656 | 3.469 | 3.469 |
| BEARING DIAMETER | .938 | .938 | 1.062 | 1.062 |

MAXIMUM OPERATING SPEED * BY TUBE SIZE, SOLID SHAFT SIZE, AND LENGTH
 *(For speed below 500 R.P.M. or over 2500 R.P.M., contact your Chelsea Distributor)

| Tubing Dia. & Wall Thickness Joint & Shaft (W=Welded S=Seamless) | MAX. INSTALLED LENGTH IN INCHES FOR GIVEN R.P.M. Centerline to Centerline of Joints For a Two Joint Assembly or Centerline of Joint to Centerline of Center Bearing For a Joint & Shaft R.P.M. - Revolutions per Minute | | | | |
|--|--|------|------|------|------|
| | 500 | 1000 | 1500 | 2000 | 2500 |
| 1.750" X .065" W | 117" | 82" | 67" | 58" | 52" |
| 1.250" X .095" S | 91" | 64" | 52" | 45" | 40" |
| 2.500" X .083" W | 122" | 87" | 70" | 62" | 55" |
| 3.000" X .083" W | - | - | - | 85" | 76" |
| SOLID SHAFT Diameter | | | | | |
| .750" | 60" | 42" | 35" | 30" | 27" |
| .812" | 62" | 44" | 36" | 31" | 28" |
| .875" | 65" | 46" | 37" | 32" | 29" |
| 1.000" | 69" | 49" | 40" | 35" | 31" |
| 1.250" | 77" | 55" | 45" | 39" | 35" |

Continuity Check

379639 and 379652 Indicator Switches

In order to insure that the switch is functioning properly, the following procedure can be used with the unit on a bench, or installed.

1. Use a continuity checker, battery type, either meter or light. Attach one (1) probe to the screw on the 379639 or 379652 Indicator Switch.

Note: Make sure 379639 and 379652 Indicator Switches in the P.T.O. shifter or housing are torqued to 10-15 lbs. ft. (1.38-2.07 kg meters).

2. With the other probe, make contact with the shifter cover or housing (Fig. 23).
3. Actuate shifting device and the meter or light* should be actuated when P.T.O. gear is engaged (Fig. 24).
4. Shift unit out of gear and the meter or light* should return to normal as shown.

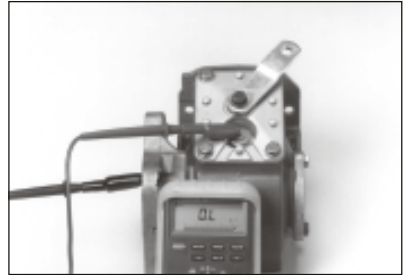

Fig. 23

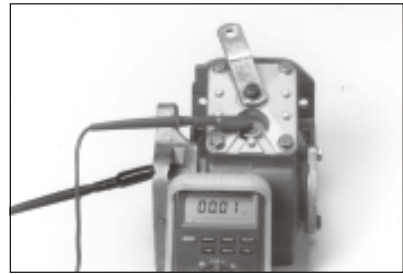

Fig. 24

This test procedure can be used to check Chelsea wire, lever, and air shifter covers, although an air source would be necessary for the latter.

* If a meter is not available the light in the 328751-1X can be used. A six volt battery is all that is necessary for a power source.

CAUTION: Indicator switches are capable of 0.5 amps maximum.

Cable Control Installation Instructions *

1. Find a suitable area on the dash to install the cable control (328346-10X) and the control plate (68-P-18) indicator light.

Optional Location: As an option the control cable and knob can be located through floor. Using this option the control plate and indicator light should still be located on dash, in close proximity.

NOTE: The location of the cable control and the control plate should be as close to each other as possible and easily accessible by the driver or operator, but should not be an obstacle to driver movement nor interfere with other controls, instruments, or equipment.

2. **CAUTION:** Before drilling any holes, make sure there is adequate room on both sides through dash wall, drill a 1/2" (.5") diameter hole for the control cable. [1]
3. Install the control cable on the dash using the hex nuts supplied with the cable. The knob can then be screwed into place [2]. The length of cable can then run through the firewall and back to the P.T.O. —making sure it is kept away from the exhaust, moving parts, etc.

NOTE: Do not kink the cable. In order for the cable to operate properly, there can be no bends smaller than 6 inch radius. Total bends in the cable should not exceed 360° (example - four 90° bends in cable).

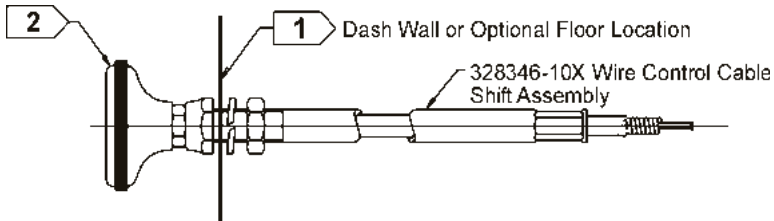

4. Using the template found on [page 42](#) (SK-168) drill the necessary holes for the control plate-indicator light.
5. Install the control plate (68-P-18) stick on decal and indicator light on the dash using the hardware supplied in the 328751-1X installation kit (Fig. 25).

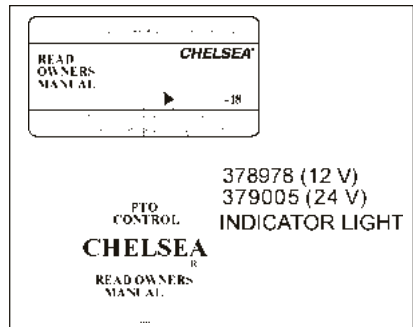

Fig. 25

* All six bolt wire shifts with the exception of the reversible, dual shift units, and some gear boxes.

Cable Control Installation Instructions * (Continued)

6. Determine from which direction the cable must come in order for the unit to be disengaged when the knob is all the way in.

NOTE: The shifter must always be installed in the following manner:

- * CABLE IN: P.T.O. DISENGAGED(6A): OUT OF GEAR POSITION
- CABLE OUT: P.T.O. ENGAGED(6B): IN GEAR POSITION

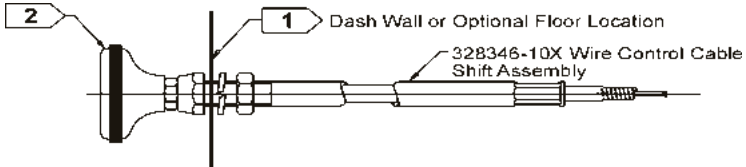

* The wire shift cable should be installed so that when the cable (knob) is shifter, to the disengaged mode.

7. Install the wire control bracket found in either the 328380X or 328380-1X wire control parts bag. [7]
8. Line the cable up with the wire control bracket and shifter lever (disengaged position) on the P.T.O. cover assembly [8]

NOTE: It may be necessary to change the position of the shifter lever on the P.T.O. To do this, remove the shifter cover from the unit. This will prevent the possible loss of the poppet and/or spring into the transmission if the shifter post assembly should be pushed through the cover when reinstalling the lever.

9. Shift the P.T.O. to the engaged position to see how much of the cable casing must be cut to allow the lever enough travel to shift in and out completely. The casing need only go just beyond the bracket, whereas, the wire must be long enough to go through the swivel pin in the shifter lever. [9]

NOTE: In some instances the cable control may not be long enough. Chelsea has available four longer lengths than the standard ten-foot cable. These come in five foot increments (i.e., 328346-15X = 15-foot cable).

10. When the length of the casing has been determined, pull the wire back through until the case can be cut without cutting the wire. Use a hacksaw or heavy pair of side cutters to cut the casing.

NOTE: The cable can be held by a bench vise as long as the jaws are not tightened to the point where the case mushrooms. If a vise is not accessible, a pair of vise grips will do the job.

* All six bolt wire shifts with the exception of the reversible, dual shift units, and some gear boxes.

Cable Control Installation Instructions * (Continued)

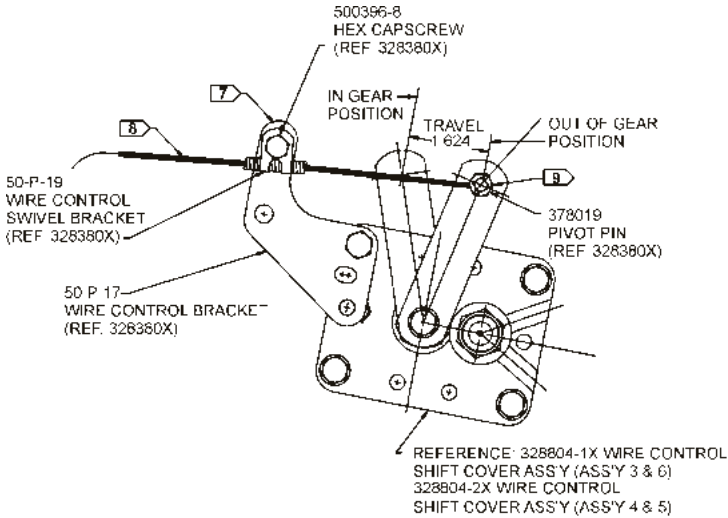

11. Push the wire back through and install the cable using the hardware from the previously mentioned wire control parts bag (328380X).
12. Cut the excess wire after the cable casing and wire have been installed and tightened.

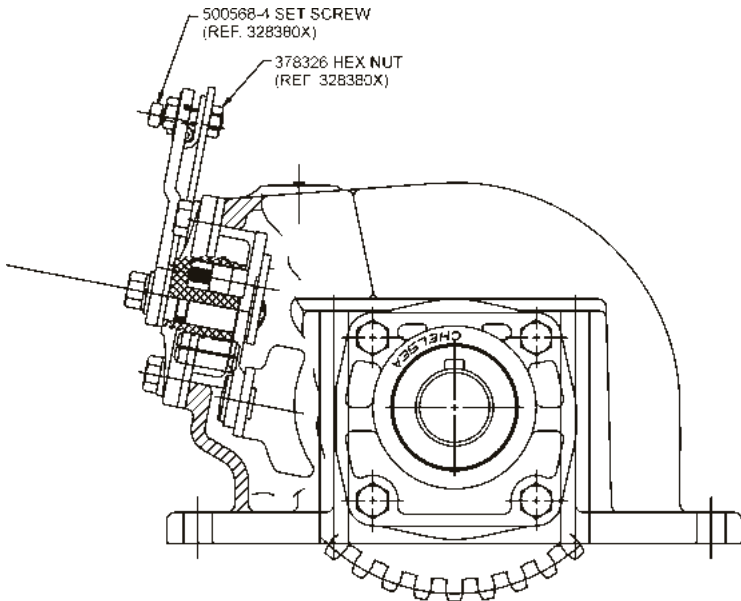

* All six bolt wire shifts with the exception of the reversible, dual shift units, and some gear boxes.

Cable Control Installation Instructions * (Continued)

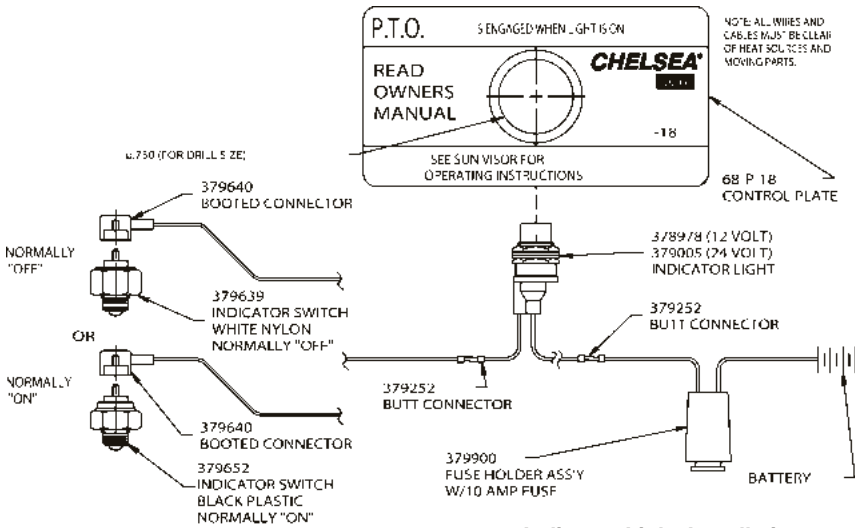

Indicator Light Installation Sketch (SK-286 Rev G)

CAUTION: Indicator switches are capable of 0.5 amps maximum.

NOTE: All wires and cables must be clear of heat source and moving parts.

- 13. Shift the P.T.O. to insure enough casing has been removed to allow full gear engagement.
- 14. Install the wiring for the indicator light using the schematic above (SK-286 Rev. G).

NOTE: Check both the cable and indicator light wires to be certain that they are not near the exhaust system or any moving parts. Carefully fasten to stationary parts of the vehicle if necessary.

- 15. Shift the P.T.O. The following should be adhered to:
 - 15A. CABLE IN: P.T.O. DISENGAGED: LIGHT OUT
 - 15B. CABLE OUT: P.T.O. ENGAGED: LIGHT ON

NOTE: The P.T.O. should be checked for continuity as per the instructions in this manual.

NOTE: Cable must be rigidly mounted-possibly to the transmission within 12-24" of the P.T.O.

* All six bolt wire shifts with the exception of the reversible, dual shift units, and some gear boxes.

Cable Control Installation Instructions (Continued) (Reversibles, dual shift units, and some gear boxes)

1. Use steps #1-#5 from previous instructions.
2. In step #6 the cable can come from either direction since the P.T.O. will always be engaged when all the way in or out.
3. Follow step #7 and #8.
4. In step #9 shift the P.T.O. from forward to reverse or vice versa to determine the amount of travel needed and the length of casing to be cut.
5. Follow step #10-#14.
6. Step #15 will show the folding:

CABLE IN: P.T.O. ENGAGED: LIGHT ON
CABLE OUT (1st position):
P.T.O. DISENGAGED: LIGHT OUT
CABLE OUT (2nd position):
P.T.O. ENGAGED: LIGHT ON

Automatic Transmissions
Pressure Lube Hose Connection

Chart I

| Dimensional Information | | | | | | |
|--------------------------------|-------------------|--------------------|--------------------|------------------|--|--|
| TEE FITTING | 378840 | 378880 | 378970 | 378897 | | |
| D | .750-16 U.N.F. 2A | .875-14 U.N.F. 2A | 1.062-12 U.N.F. 2A | 1.312-12 U.N. 2A | | |
| E | .250-18 N.P.T.F. | .250-18 N.P.T.F. | .250-18 N.P.T.F. | .250-18 N.P.T.F. | | |
| F | .750-16 N.P.T.F. | .875-14 U.N.F. 2NB | 1.062-12 U.N.F. 2B | 1.312-12 U.N. 2B | | |

| Allison 1000, 2000/2400 Series Converter Housing Options | | | | | | |
|---|-------------------|-----------------------|-------------|-------------|-------------|------------------------|
| Converter Housing Group Number | SAE Number | Description | 1000 | 2000 | 2400 | Chelsea Fitting |
| 34-561 | #3 | Integral Cooler Ports | STD. | --- | --- | 378840 |
| 34-562 | #2 | Manifold Pad | OPT. | STD. | STD. | 378970 |
| 34-563 | #3 | Manifold Pad | OPT. | STD. | STD. | 378970 |
| 34-565 | #3 | Integral Cooler Ports | STD. | --- | --- | 378840 |
| 34-566 | #2 | Manifold Pad | OPT. | STD. | STD. | 378970 |
| 34-567 | #2 | Manifold Pad | OPT. | STD. | STD. | 378970 |
| 34-572 | #3 | Integral Cooler Ports | STD. | --- | --- | 378840 |
| 34-573 | #3 | Integral Cooler Ports | STD. | --- | --- | 378840 |

The specific "T" fitting for each Automatic Transmission is called out at the bottom of each transmission's application sheet. If a "T" fitting is not called out, then a standard pipe tee will adapt.

**442 Series Pressure Lube for Allison 1000, 2000/2400 Series
(SK-382 Rev B)**

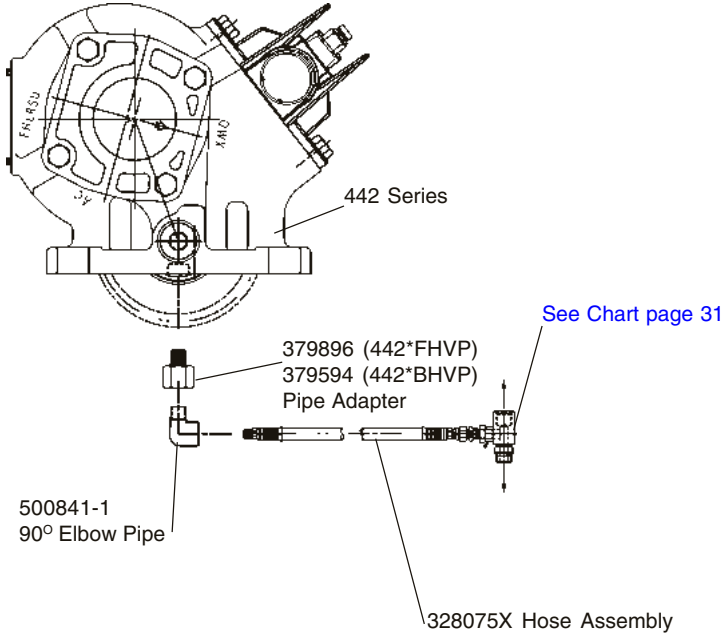

P.T.O. Openings for Automatic Transmissions Allison Models

**HT-740
 HT-750D**

T Fitting 378897

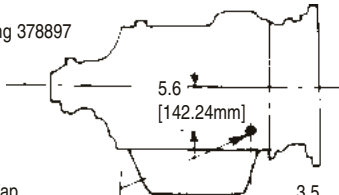

Lube Tap
 1 5/16 O-Ring 35-45 P.S.I.
 2.4-3.2 Kg/cm²

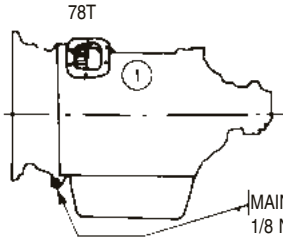

MAIN PRESSURE
 1/8 N.P.T. 90-175 P.S.I.
 6.3-12.2 Kg/cm²

CLT-750

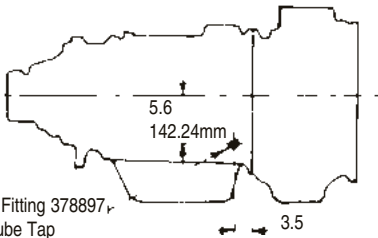

T Fitting 378897
 Lube Tap
 1 5/16 O-Ring 35-45 P.S.I.
 2.4-3.2 Kg/cm²

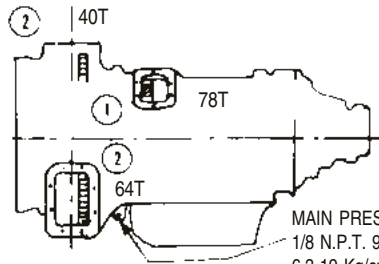

MAIN PRESSURE
 1/8 N.P.T. 90-270 P.S.I.
 6.3-19 Kg/cm²

HT-70

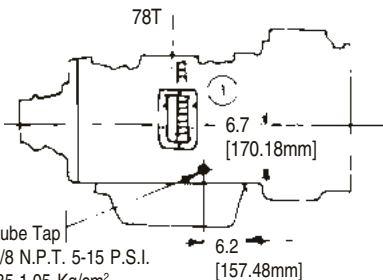

Lube Tap
 1/8 N.P.T. 5-15 P.S.I.
 .35-1.05 Kg/cm²

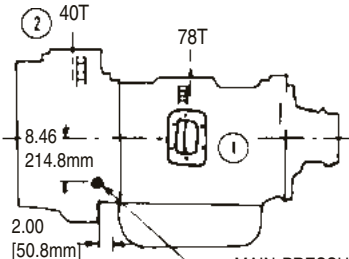

MAIN PRESSURE
 1/8 N.P.T. 90-240 P.S.I.
 7.7-16.8 Kg/cm²

1. Converter driven P.T.O. Drive Gear.
2. Engine driven P.T.O. Drive Gear.

P.T.O. Openings (Continued)

5000 Series

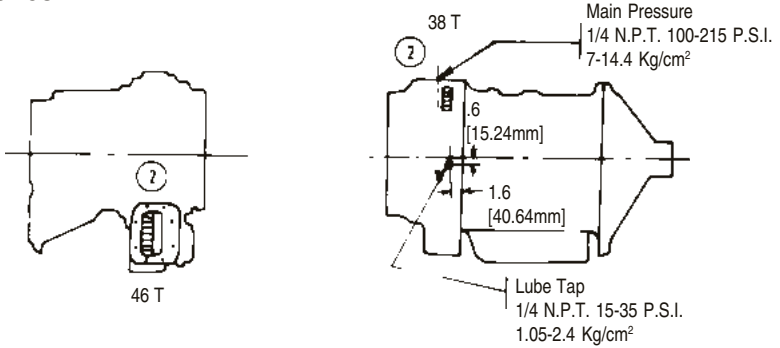

8000 Series

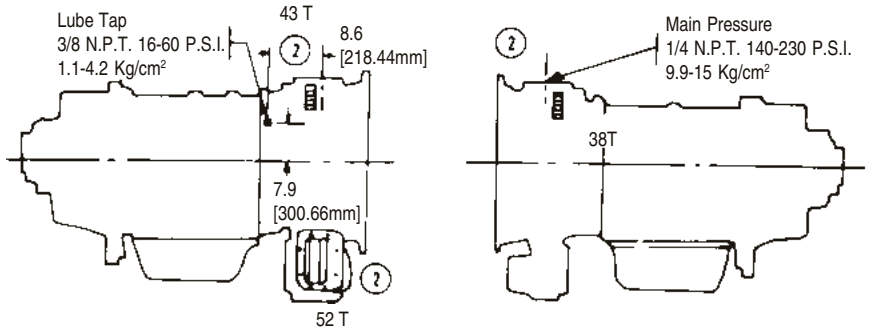

1000, 2000/2400 Series

Install Tee Fitting Here
 "From" Cooler Return Port

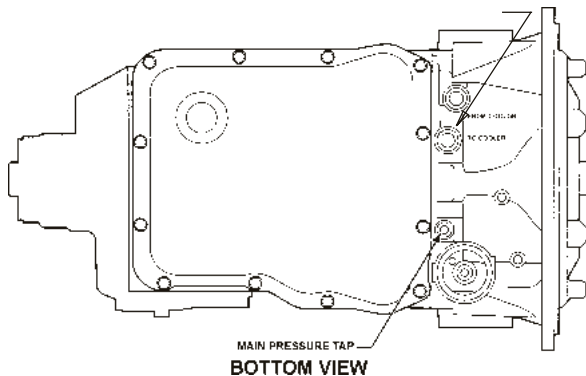

1. Converter driven P.T.O. Drive Gear.
2. Engine driven P.T.O. Drive Gear.

P.T.O. Openings (Continued)

MT-30-42 (57 Teeth)
6 Speed

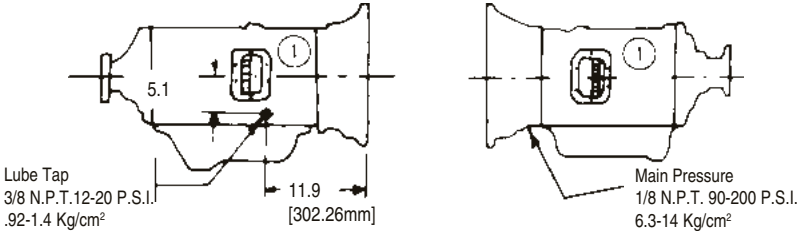

3341 - 3441 (55 Teeth)
AT-540

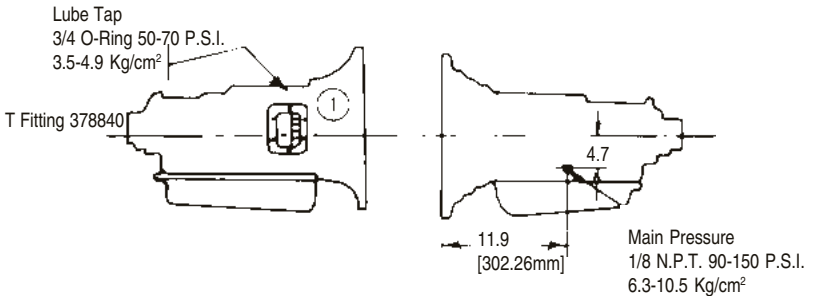

4 Speed (64 Teeth)
MT-640

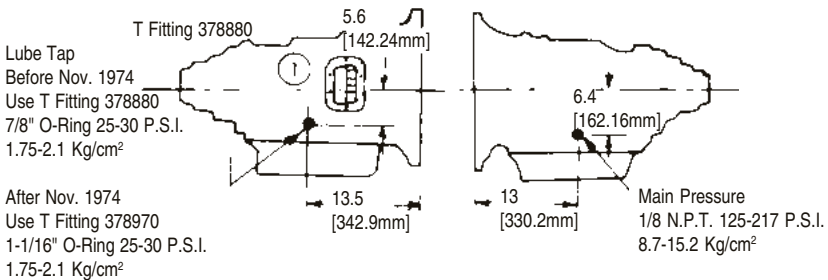

1. Converter driven P.T.O. Drive Gear.

P.T.O. Shifting Procedure & Precautions

This vehicle is equipped with a **POWER TAKE-OFF**

Shut Engine Off Before Working On Power Take-Off Or Getting Below Vehicle.

Consult Operating Instructions Before Using. (See Sun Visor)

POWER TAKE-OFF OPERATION VEHICLE STATIONARY

I. Manual Transmission

1. A Power Take-Off is, and should be, operated as an integral part of the main transmission.
2. Before shifting the Power Take-Off into or out of gear disengage the clutch and wait for transmission or P.T.O. gears to stop rotating.

II. Automatic Transmission with Manual Shift P.T.O. (Includes Air Shift)

On automatic transmissions, the gears in the transmission turn when the transmission is in neutral, therefore, gear clashing will occur if the power take-off is shifted into gear at this time.

A. With Converter Driven Gear:

1. Shift transmission lever into any of the drive positions (this will stop transmission gear from turning).
2. Shift Power Take-Off into gear.
3. Shift transmission into neutral (this will start gears turning).

B. With Engine Driven Gear:

1. Shift P.T.O. into gear before starting engine. This procedure should eliminate gear clash.

III. Automatic Transmission with Powershift P.T.O.

Engage P.T.O. with engine at idle speed.

Power Shift P.T.O.s: Engine must be at idle when P.T.O. is engaged.

See transmission manufacturer's instructions for special procedures.

IMPORTANT: Failure to follow proper shifting or operating sequences will result in premature P.T.O. failure with possible damage to other equipment.



WARNING

Use only wire control with P.T.O. made for wire cable control. If lever control is desired, order P.T.O. for lever control. The internal shifting mechanism for wire is not designed for heavy forces usually encountered with lever control linkage.

Do not attempt to work on an installed Power Take-Off with the engine running.

Make sure to block any moving or raised device that may injure a person working on or under the truck. A lever or its linkage may be accidentally moved causing movement of the device which could cause injury to a person near the device.

**Air Shift Installation Sketch for 340 and 352 Series Using:
 Williams Valve (SK-228 Rev G)**

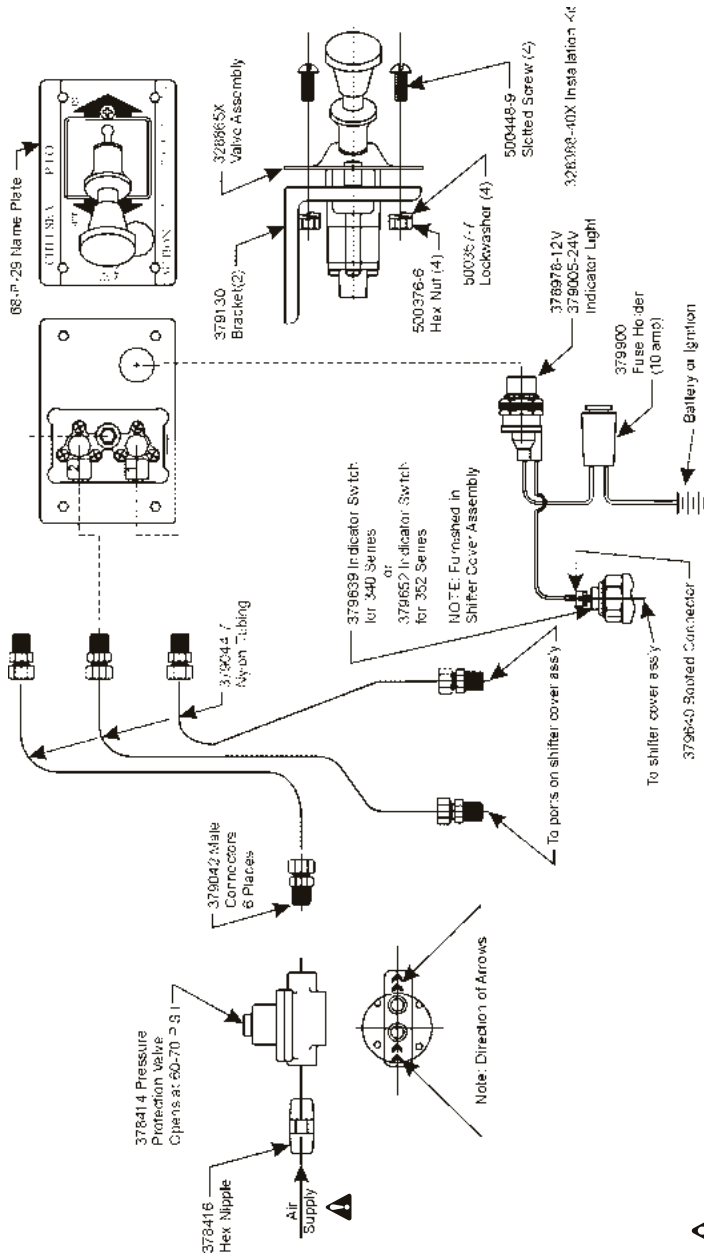

Warning: Connect directly to air supply.
 Do not use tubing between air supply and pressure protection valve.

Caution: When installing nylon tubing avoid sharp angles, exhaust and manifold systems.

Note: Tube nut is reusable as long as nylon tubing is not removed from the tube nut.

Note: Template for control plate on page 44.

**Air Shift Installation Sketch for 880 and 823 Series Using:
 Williams Valve (SK-276 Rev H)**

328388-61X Installation Kit

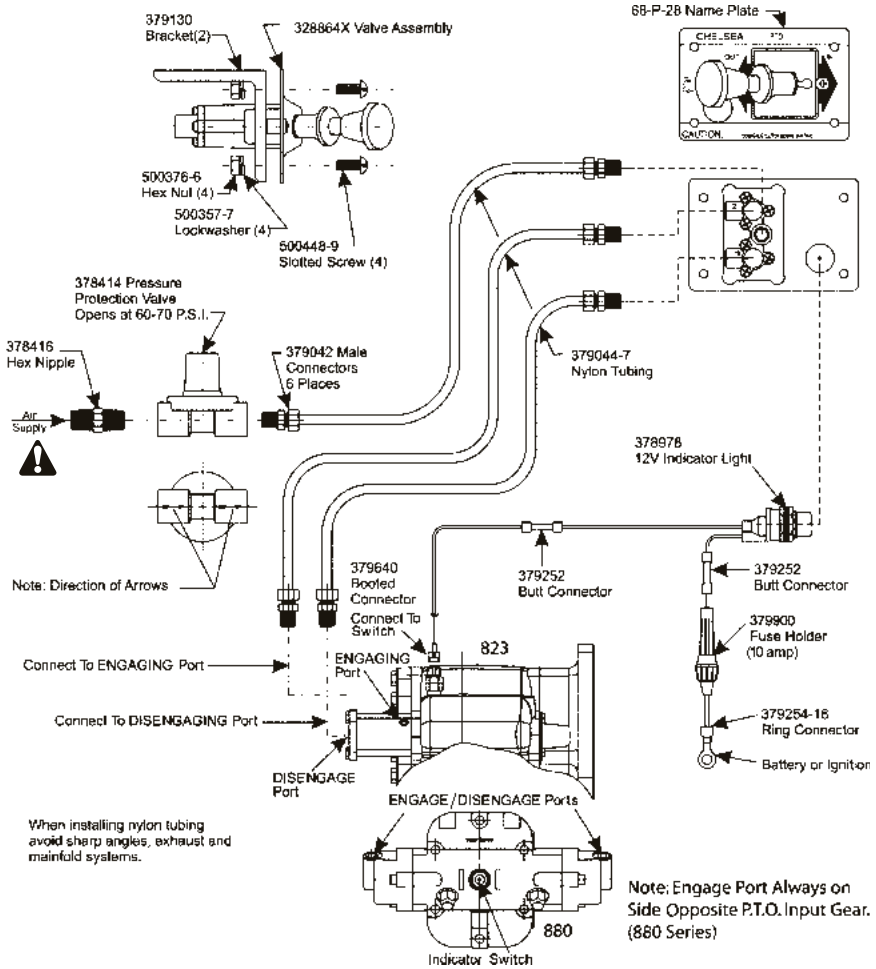

Warning: Connect directly to the air supply. Do not use tubing between the air supply and the pressure protection valve.

Caution: When installing nylon tubing avoid sharp angles, exhaust and manifold systems.

Important: When this installation is used on vehicles with automatic transmissions, the P.T.O. drive gear must be stopped before shifting.

NOTE: Tube nut is reusable as long as nylon tubing is not removed from the tube nut.

NOTE: The template for the control plate is on [page 44](#).

Air Shift Installation Sketch for 100, 221, 260, 429, 434, 435, 436, 437, 438, 442, 447, 489, 660, 680 and 812 Series Using: Williams Valve (SK-231 Rev D)

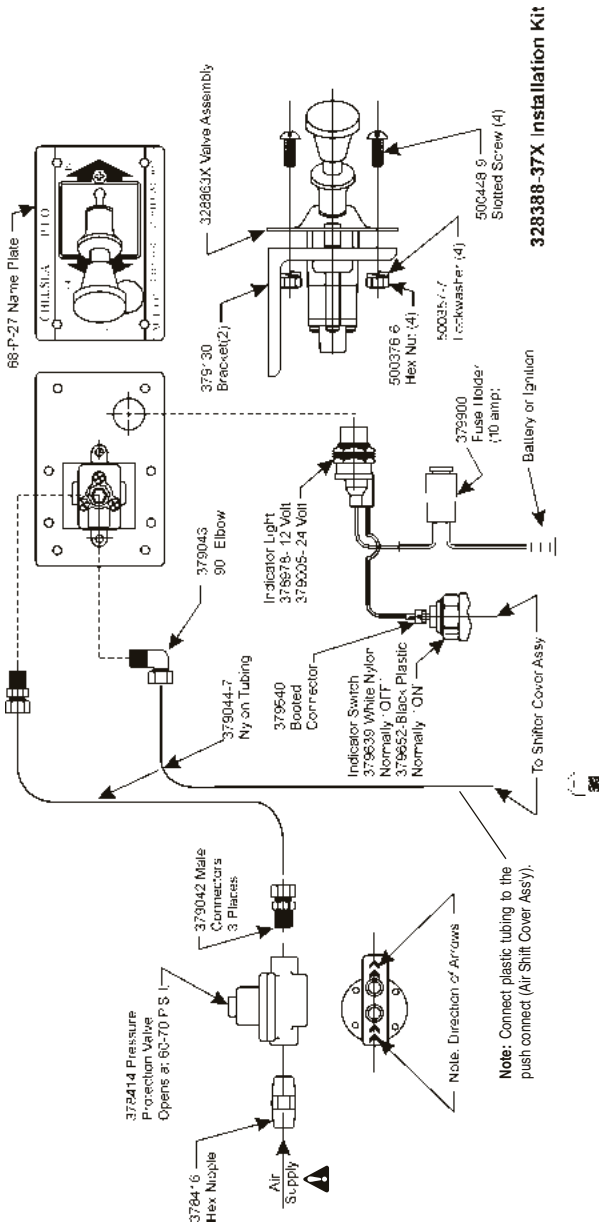

328388-37X Installation Kit

Warning: Connect directly to air supply. Do not use tubing between air supply and pressure protection valve.

Caution: When installing nylon tubing avoid sharp angles, exhaust and manifold systems.

Important: When this installation is used on vehicles with automatic transmissions the P.T.O. drive gear must be stopped before shifting.

Note: Tube nut is reusable as long as nylon tubing is not removed from the tube nut.

Note: Template for control plate on [page 44](#).

Installing Rotatable Flanges

The rotatable flange is shipped loose with the P.T.O. units for ease of installation. After determining the flange position, attach the flange to the P.T.O. bearing cap using the capscrews provided in the bag kit. Bag kit number 328170-207X (6-bolt family) will contain (3) capscrews (378447-6) and 328170-208X (277 Series) will contain (4) capscrews for attaching the flange to the P.T.O. bearing cap.

After installing the capscrews make sure to torque the screws to 16-20 lbs. ft.

Consideration should be taken on the size and weight of the pump being installed. (see [pages 3 and 4](#))

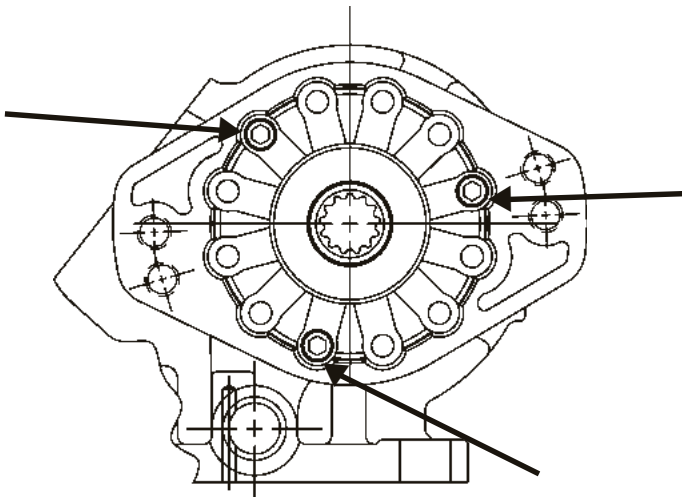

RB Flange Shown

NOTE: Reinstalling or tightening of a rotatable flange after it has become loose is not recommended. If a P.T.O. has run for length of time after the flange has become loose, the flange and / or bearing cap may not be to manufacturing tolerance.

Indicator Light Installation & Dash Drilling Template (SK-286 Rev G)

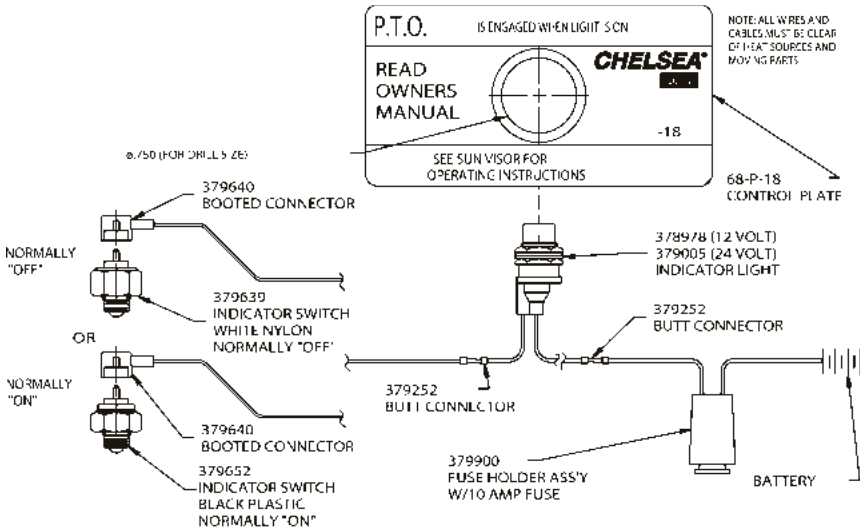

CAUTION: Indicator switches are capable of 0.5 amps maximum.

NOTE: All wires and cables must be clear of heat source and moving parts.

Dash Drilling Template (SK-168)

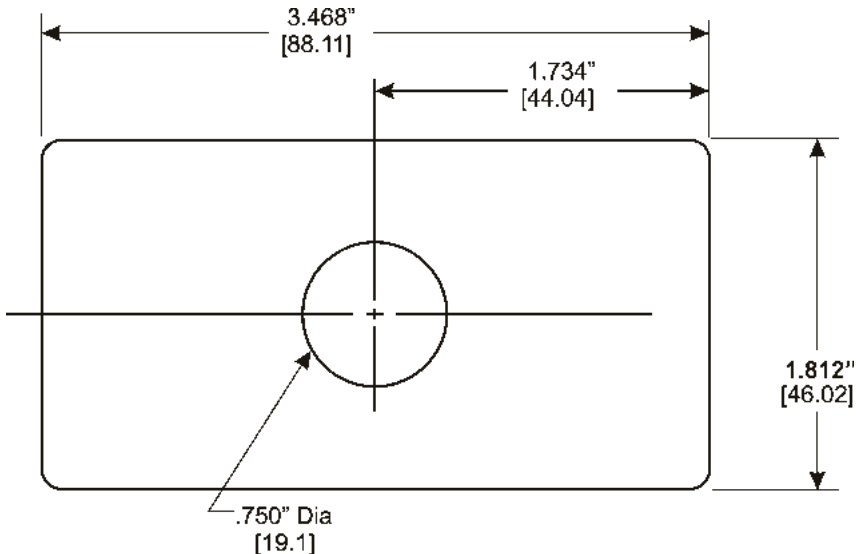

Dash Drilling Template for 6 & 8 Bolt Air Shift for Williams Valve (SK-204 REV C)

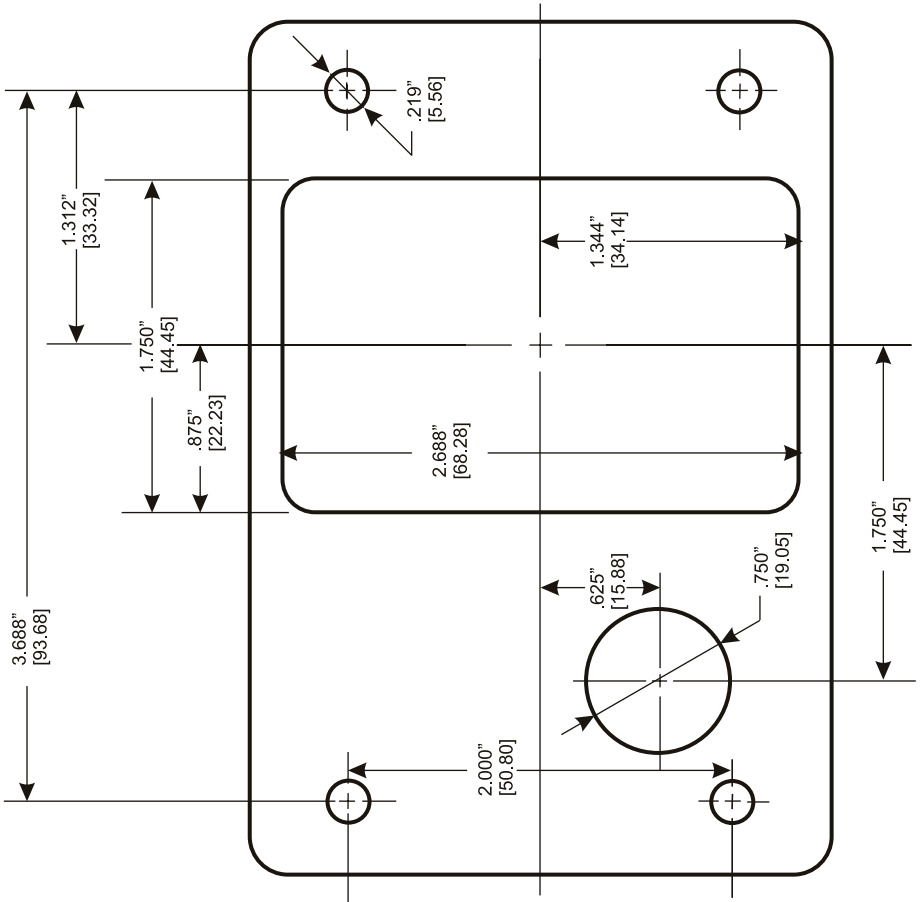

Power Take-Off Maintenance

Due to the normal and sometime severe torsional vibrations that Power Take-Off units experience, operators should follow a set maintenance schedule for inspections. Failure to service loose bolts or Power Take-Off leaks could result in potential auxiliary Power-Take-Off or transmission damage.

Periodic P.T.O. MAINTENANCE is required by the owner/operator to ensure proper, safe and trouble free operation.

Daily: Check all air, hydraulic and working mechanisms before operating P.T.O. Perform maintenance as required.

Monthly: Inspect for possible leaks and tighten all air, hydraulic and mounting hardware, if necessary. Torque all bolts, nuts, etc. to Chelsea specifications. Insure that splines are properly lubricated, if applicable. Perform maintenance as required.

With regards to the direct mounted pump splines, the P.T.O. requires the application of a specially formulated anti-fretting, high pressure, high temperature grease. The addition of the grease has been proven to reduce the effects of the torsional vibrations, which result in fretting corrosion on the P.T.O. internal splines as well as the pump external splines. Fretting corrosion appears as a "rusting and wearing" of the pump shaft splines. Severe duty applications, which require long P.T.O. running times and high torque may require more frequent regreasing. Applications such as Utility Trucks that run continuously and are lightly loaded also require frequent regreasing due to the sheer hours of running time. It is important to note that service intervals will vary for each and every application and is the responsibility of the end user of the product. Chelsea also recommends that you consult your pump owners manuals and technical services for their maintenance guidelines. Fretting corrosion is caused by many factors and without proper maintenance; the anti-fretting grease can only reduce its effects on components.

Chelsea offers the grease to our customers in two packages. The first is a 5/8 fluid ounce tube (379688), which is included with every applicable P.T.O., and the second is a 14-ounce grease cartridge (379831). Chelsea also offers greaseable shafts for most all output designators.

Warranty: Failure to comply entirely with the provisions set forth in the appropriate Owner's Manual will result in voiding of ALL Warranty consideration.

Offer of Sale

The items described in this document and other documents or descriptions provided by Parker Hannifin Corporation, its subsidiaries and its authorized distributors are hereby offered for sale at prices to be established by Parker Hannifin Corporation, its subsidiaries and its authorized distributors. This offer and its acceptance by any customer ("Buyer") shall be governed by all of the following Terms and Conditions. Buyer's order for any such items, when communicated to Parker Hannifin Corporation, its subsidiary or an authorized distributor ("Seller") verbally or in writing, shall constitute acceptance of this offer.

1. Terms and Conditions of Sale: All descriptions, quotations, proposals, offers, acknowledgments, acceptances and sales of Seller's products are subject to and shall be governed exclusively by the terms and conditions stated herein. Buyer's acceptance of any offer to sell is limited to these terms and conditions. Any terms or conditions in addition to, or inconsistent with those stated herein, proposed by Buyer in any acceptance of an offer by Seller, are hereby objected to. No such additional, different or inconsistent terms and conditions shall become part of the contract between Buyer and Seller unless expressly accepted in writing by Seller. Seller's acceptance of any offer to purchase by Buyer is expressly conditional upon Buyer's assent to all the terms and conditions stated herein, including any terms in addition to, or inconsistent with those contained in Buyer's offer. Acceptance of Seller's products shall in all events constitute such assent.

2. Payment: Payment shall be made by Buyer net 30 days from the date of delivery of the items purchased hereunder. Amounts not timely paid shall bear interest at the maximum rate permitted by law for each month or portion thereof that the Buyer is late in making payment. Any claims by Buyer for omissions or shortages in a shipment shall be waived unless Seller receives notice thereof within 30 days after Buyer's receipt of the shipment.

3. Delivery: Unless otherwise provided on the face hereof, delivery shall be made F.O.B. Seller's plant. Regardless of the method of delivery, however, risk of loss shall pass to Buyer upon Seller's delivery to a carrier. Any delivery dates shown are approximate only and Seller shall have no liability for any delays in delivery.

4. Warranty: Seller warrants that the items sold hereunder shall be free from defects in material or workmanship for a period of:
(A) All Power Take-Off units one (1) year from date of installation.
(B) Except 267, 277, 278, 242, 244, 246, 250, 251 and 859 series two (2) years from date of installation.

THIS WARRANTY COMPRISES THE SOLE AND ENTIRE WARRANTY PERTAINING TO ITEMS PROVIDED HEREUNDER. SELLER MAKES NO OTHER WARRANTY, GUARANTEE, OR REPRESENTATION OF ANY KIND WHATSOEVER. ALL OTHER WARRANTIES, INCLUDING BUT NOT LIMITED TO, MERCHANTABILITY AND FITNESS FOR PURPOSE, WHETHER EXPRESS, IMPLIED, OR ARISING BY OPERATION OF LAW, TRADE USAGE, OR COURSE OF DEALING ARE HEREBY DISCLAIMED. NOTWITHSTANDING THE FOREGOING, THERE ARE NO WARRANTIES WHATSOEVER ON ITEMS BUILT OR ACQUIRED WHOLLY OR PARTIALLY, TO BUYER'S DESIGNS OR SPECIFICATIONS.

5. Limitation Of Remedy: SELLER'S LIABILITY ARISING FROM OR IN ANY WAY CONNECTED WITH THE ITEMS SOLD OR THIS CONTRACT SHALL BE LIMITED EXCLUSIVELY TO REPAIR OR REPLACEMENT OF THE ITEMS SOLD OR REFUND OF THE PURCHASE PRICE PAID BY BUYER, AT SELLER'S SOLE OPTION. IN NO EVENT SHALL SELLER BE LIABLE FOR ANY INCIDENTAL, CONSEQUENTIAL OR SPECIAL DAMAGES OF ANY KIND OR NATURE WHATSOEVER, INCLUDING BUT NOT LIMITED TO LOST PROFITS ARISING FROM OR IN ANY WAY CONNECTED WITH THIS AGREEMENT OR ITEMS SOLD HEREUNDER, WHETHER ALLEGED TO ARISE FROM BREACH OF CONTRACT, EXPRESS OR IMPLIED WARRANTY, OR IN TORT, INCLUDING WITHOUT LIMITATION, NEGLIGENCE, FAILURE TO WARN OR STRICT LIABILITY.

6. Changes, Reschedules and Cancellations: Buyer may request to modify the designs or specifications for the items sold hereunder as well as the quantities and delivery dates thereof, or may request to cancel all or part of this order, however, no such requested modification or cancellation shall become part of the contract between Buyer and Seller unless accepted by Seller in a written amendment to this Agreement. Acceptance of any such requested modification or cancellation shall be at Seller's discretion, and shall be upon such terms and conditions as Seller may require.

7. Special Tooling: A tooling charge may be imposed for any special tooling, including without limitation, dies, fixtures, molds and patterns, acquired to manufacture items sold pursuant to this contract. Such special tooling shall be and remain Seller's property notwithstanding payment of any charges by Buyer. In no event will Buyer acquire any interest in apparatus belonging to Seller which is utilized in the manufacture of the items sold hereunder, even if such apparatus has been specially converted or adapted for such manufacture and notwithstanding any charges paid by Buyer. Unless otherwise agreed, Seller shall have the right to alter, discard or otherwise dispose of any special tooling or other property in its sole discretion at any time.

8. Buyer's Property: Any designs, tools, patterns, materials, drawings, confidential information or equipment furnished by Buyer or any other items which become Buyer's property, may be considered obsolete and may be destroyed by Seller after two (2) consecutive years have elapsed without Buyer placing an order for the items which are manufactured using such property. Seller shall not be responsible for any loss or damage to such property while it is in Seller's possession or control.

9. Taxes: Unless otherwise indicated on the face hereof, all prices and charges are exclusive of excise, sales, use, property, occupational or like taxes which may be imposed by any taxing authority upon the manufacture, sale or delivery of the items sold hereunder. If any such taxes must be paid by Seller or if Seller is liable for the collection of such tax, the amount thereof shall be in addition to the amounts for the items sold. Buyer agrees to pay all such taxes or to reimburse Seller therefore upon receipt of its invoice. If Buyer claims exemption from any sales, use or other tax imposed by any taxing authority, Buyer shall save Seller harmless from and against any such tax, together with any interest or penalties thereon which may be assessed if the items are held to be taxable.

10. Indemnity For Infringement of Intellectual Property Rights: Seller shall have no liability for infringement of any patents, trademarks, copyrights, trade dress, trade secrets or similar rights except as provided in this Part 10. Seller will defend and indemnify Buyer against allegations of infringement of U.S. Patents, U.S. Trademarks, copyrights, trade dress and trade secrets (hereinafter 'Intellectual Property Rights'). Seller will defend at its expense and will pay the cost of any settlement or damages awarded in an action brought against Buyer based on an allegation that an item sold pursuant to this contract infringes the Intellectual Property Rights of a third party. Seller's obligation to defend and indemnify Buyer is contingent on Buyer notifying Seller within ten (10) days after Buyer becomes aware of such allegations of infringement, and Seller having sole control over the defense of any allegations or actions including all negotiations for settlement or compromise. If an item sold hereunder is subject to a claim that it infringes the Intellectual Property Rights of a third party, Seller may, at its sole expense and option, procure for Buyer the right to continue using said item, replace or modify said item so as to make it noninfringing, or offer to accept return of said item and return the purchase price less a reasonable allowance for depreciation. Notwithstanding the foregoing, Seller shall have no liability for claims of infringement based on information provided by Buyer, or directed to items delivered hereunder for which the designs are specified in whole or part by Buyer, or infringements resulting from the modification, combination or use in a system of any item sold hereunder. The foregoing provisions of this Part 10 shall constitute Seller's sole and exclusive liability and Buyer's sole and exclusive remedy for infringement of Intellectual Property Rights. If a claim is based on information provided by Buyer or if the design for an item delivered hereunder is specified in whole or in part by Buyer, Buyer shall defend and indemnify Seller for all costs, expenses or judgments resulting from any claim that such item infringes any patent, trademark, copyright, trade dress, trade secret or any similar right.

11. Force Majeure: Seller does not assume the risk of and shall not be liable for delay or failure to perform any of Seller's obligations by reason of circumstances beyond the reasonable control of Seller (hereinafter 'Events of Force Majeure'). Events of Force Majeure shall include without limitation, accidents, acts of God, strikes or labor disputes, acts, laws, rules or regulations of any government or government agency, fires, floods, delays or failures in delivery of carriers or suppliers, shortages of materials and any other cause beyond Seller's control.

12. Entire Agreement/Governing Law: The terms and conditions set forth herein, together with any amendments, modifications and any different terms or conditions expressly accepted by Seller in writing, shall constitute the entire Agreement concerning the items sold, and there are no oral or other representations or agreements which pertain thereto. This Agreement shall be governed in all respects by the law of the State of Ohio. No actions arising out of the sale of the items sold hereunder or this Agreement may be brought by either party more than two (2) years after the cause of action accrues.

1/06-P



Parker Hannifin Corporation

Chelsea Products Division

8225 Hacks Cross Road

Olive Branch, Mississippi 38654 USA

Tel: (662) 895-1011

Fax: (662) 895-1019

www.parker.com/chelsea

FP 02/07 20M